

**TITAN**®  
TOOL INC.



OWNER'S MANUAL  
FOR PROFESSIONAL  
USE ONLY

313 - 1233 0799B

**TITAN** *Speeflo*



DO NOT USE EQUIPMENT BEFORE READING THIS MANUAL

# Epic™ 1200HPG

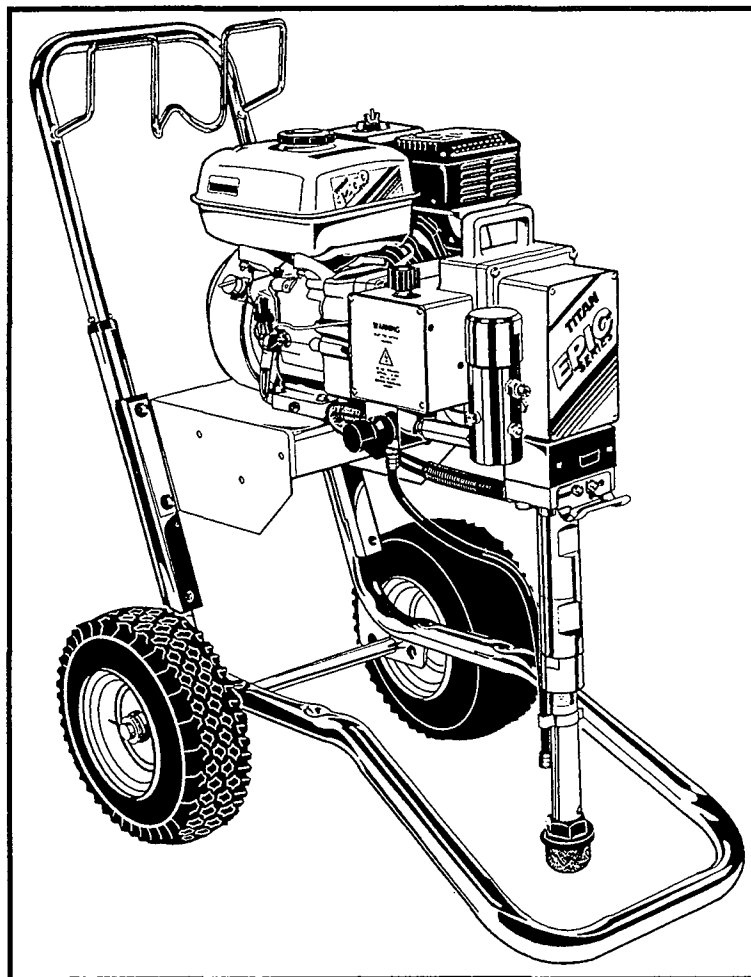

## Epic 1200HPG

High Rider Pump Complete - 783-100    Low Rider Pump Complete - 783-110  
High Rider Pump Only - 783-101        Low Rider Pump Only - 783-111

This manual contains important warnings and instructions.

Please read and retain for reference.

Never operate this unit unless it is properly grounded.

# Epic 1200HPG

## Table of Contents

Accessories	2
General Repairs/Service	3
Maintenance/Service Record	4
Warnings	5
Aviso (En Español)	6
Attention (En Français)	7
Notice: Fire or Explosion Hazards	8, 9, 10
Start-up Procedure	10, 11
Application Techniques	12
Cleaning Procedure	13
Airless Tip Selection	13
Troubleshooting	13
Spray Pattern	
Airless Gun	
Tips Selection	
Flushing Specifications	14
Troubleshooting Airless Pump	14

## Parts Drawings & Repair Information 15-25

Frame.....	15
Replacement Labels.....	16
Engine.....	18
Maintenance.....	19
Clutch Service.....	19
Gear Box.....	20
Clutch Rotor & Gear Repair.....	21
On/Off Switch .....	21
Filter/Manifold.....	22
Pressure Switch.....	23
Prime Relief Valve.....	22
Filter Replacement.....	22
Syphon Assembly.....	23
Fluid Section.....	24
Pump Repair, Packings.....	25
Equipment Job History.....	26
Specifications.....	28
Warranty.....	28



**WARNING:** The Engine Exhaust from this product contains chemicals known to the state of California to cause cancer, birth defects, or other reproductive harm.

U.S. Patents: 3,936,002; 4,220,286; 4,457,472; 4,508,268; 4,494,697; 4,500,119; 4,626,004; 4,611,758; 4,744,571; 4,728,213; 4,768,932; 4,755,638; 4,768,929; 4,840,543; 4,908,538; 5,074,467; 5,425,506

## Accessories

### LIQUID SHIELD

Cleans and protects spray systems against rust, corrosion and premature wear.

Case of 12 (1 quart bottles) 700-888  
1 quart 700-889



### PISTON SEAL LUBRICANT

Specially formulated to prevent materials from adhering to the piston rod, which becomes abrasive to the upper seals. Piston Lube will break down any material that may accumulate in the wet cup and keep it from drying.

8 oz individual 700-925  
1 qt individual 700-926  
8 oz, case of 12 700-911  
1 qt, case of 12 700-912



### AIRLESS HOSE

I.D.x Length	Product No.
1/4" x 50'	316-505
3/8" x 50'	690-375-50
3/16" x 15'	550-221

### HIGH PRESSURE SWIVELS

Pressure Rated at 5000 psi

#### Gun-to-Hose

1/4" NPS (F) x 1/4" NPS (M) 500-428

#### Hose-to-Hose

1/4" NPS (M) x 1/4" NPS(M) 500-424

### FITTINGS

1/4" x 1/4" Hose Coupling	490-012
1/4" x 3/8" Hose Coupling	490-016
3/8" x 3/8" Hose Coupling	490-014
T-Fittings, 1/4" X 1/4"	490-036
4 Gun Manifold	500-056
Tip Filter Retainer	520-046
1/4" Mx1/4"F Swivel Union	490-005
1/4" Mx3/8"F Swivel Union	490-032
Retaining Nut Adapter	490-007
High Pressure Fl. Gauge	730-394

# Epic 1200HPG

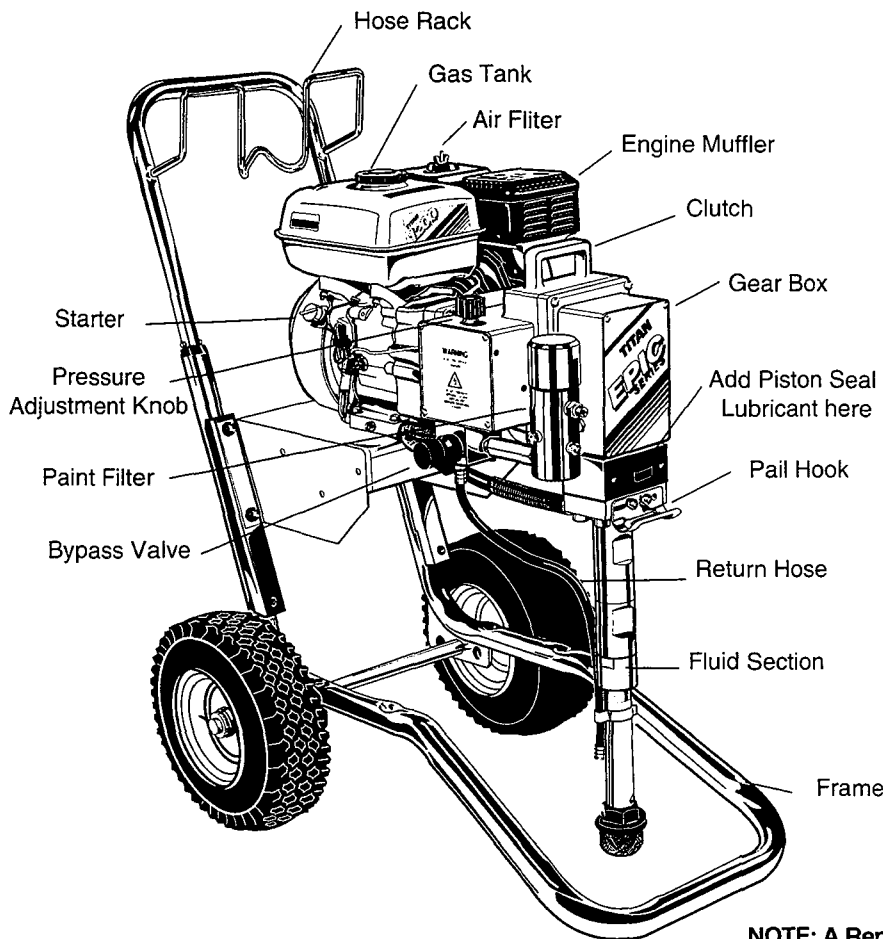

Figure 1

Figure 2

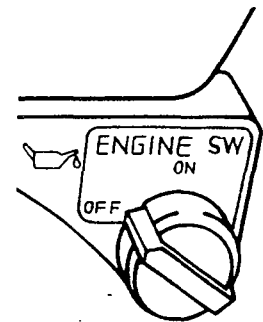
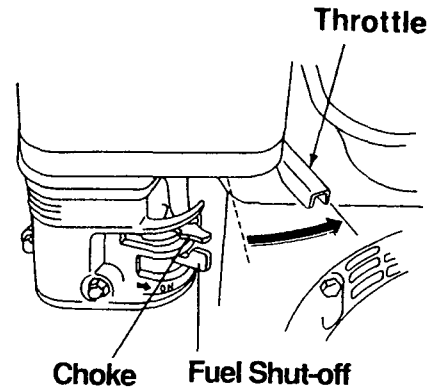

Figure 3

**NOTE:** A Repacking Kit (762-175) is available. All parts included in the kits are listed in parts list chart on page 24. For best results use all parts supplied in the Repacking Kit.

## General Repair & Service Notes:

**WARNING:** Before proceeding, follow the Pressure Relief Procedure outlined on Page 5. Additionally, follow all other warnings to reduce the risk of an injection injury, injury from moving parts or electric shock.

The following tools are needed when repairing this sprayer:

Phillips Screwdriver	3/8" Allen Wrench
Needle Nose Pliers	5/16" Allen Wrench
Adjustable Wrench	1/4" Allen Wrench
Rubber Mallet	3/16" Allen Wrench
Flat-blade Screwdriver	1/8" Allen Wrench
1/2" Open End Wrench	

1. Before repairing any part of the sprayer, read the instructions carefully, including all warnings.
2. When disconnecting wires, use needle nose pliers to separate mating connectors.

**CAUTION:** Never pull on a wire to disconnect it. Pulling on a wire could loosen the connector from the wire.

3. Test your repair before regular operation of the sprayer to be sure that the problem is corrected. If the sprayer does not operate properly, review the repair procedure to determine if everything was done correctly. Refer to the Troubleshooting Charts to help identify other possible problems.
4. Make certain that the service area is well ventilated in case solvents are used during cleaning. Always wear protective eyewear while servicing. Additional protective equipment may be required depending on the type of cleaning solvent. Always contact the supplier of solvents for recommendations.
5. If you have any further questions concerning your **TITAN** Airless Sprayer, call **TITAN:**

Customer Service Department **1-800-526-5362**  
 Fax **1-800-528-4826**  
 Outside the U.S. Call **1-201-405-7520**  
 Outside the U.S. Fax **1-201-405-7449**  
 Canada **1-800-565-8665**  
 Fax **1-905-856-8496**

MODEL #	SERIAL #	DATE PURCHASED	COMPANY NAME
---------	----------	----------------	--------------

Titan Tool is in the business of designing and manufacturing spray systems and accessories that make today's Painting Professional become more efficient and profitable. We feel that if you accurately track the maintenance of your equipment on this chart it will improve the performance of this valuable tool to help you get the most out of your investment.

The chart is easy to follow and to use. The Maintenance Schedule allows for the recording of all your service work and will help you make sure your unit is always running at peak performance.

Make sure to fill in the boxes at the top of this record with the model number, serial number, date purchased and your company name. This information will be needed to validate your warranty.

## Gas Pump Maintenance Schedule

**Check Piston Seal Lubricant Level WEEKLY.**

**EPIC 1200HPG**

<b>Change Engine Oil Every 50 Hours</b>	Date	Date	Date	Date	Date	Date	Date	Date	Date	Date
---	------	------	------	------	------	------	------	------	------	------

### Clean Air Filter Daily

It is extremely important to clean the air filter daily. Consult the Honda Engine Manual supplied with your unit for proper cleaning instructions.

<b>Air Filter Replaced</b>	Date	Date	Date	Date	Date	Date	Date	Date	Date	Date
----------------------------	------	------	------	------	------	------	------	------	------	------

## Service Record

Date	Service Center	Service Performed	Warranty Repair <input type="checkbox"/> Yes <input type="checkbox"/> No
Months in Service	Cost of Repair		
Date	Service Center	Service Performed	Warranty Repair <input type="checkbox"/> Yes <input type="checkbox"/> No
Months in Service	Cost of Repair		
Date	Service Center	Service Performed	Warranty Repair <input type="checkbox"/> Yes <input type="checkbox"/> No
Months in Service	Cost of Repair		
Date	Service Center	Service Performed	Warranty Repair <input type="checkbox"/> Yes <input type="checkbox"/> No
Months in Service	Cost of Repair		
Date	Service Center	Service Performed	Warranty Repair <input type="checkbox"/> Yes <input type="checkbox"/> No
Months in Service	Cost of Repair		

May Be Copied For Field Use

**DO NOT USE EQUIPMENT BEFORE READING THIS SECTION**

**WARNING**  
**HIGH PRESSURE SPRAY**  
**CAN CAUSE SERIOUS INJURY**  
**Maximum Working Pressure 3200 psi, 221 bar**

An airless spray gun requires that fluid be introduced to it at very high pressure. Fluids under high pressure, from spray or leaks, can penetrate the skin and inject substantial quantities of toxic fluid into the body. If not promptly and properly treated, the injury can cause tissue death or gangrene and may result in serious, permanent disability or amputation of the wounded part. Therefore, extreme caution must be exercised when using any airless spray equipment. **IF YOU ARE INJECTED, SEE A PHYSICIAN IMMEDIATELY. DO NOT TREAT AS A SIMPLE CUT!**

**NOTE TO PHYSICIAN:** Injection into the skin is a serious, traumatic injury. It is important to treat the injury surgically as soon as possible. Do not delay treatment to research toxicity. Toxicity is a concern with some exotic coatings injected directly into the bloodstream. Consultation with a plastic surgeon or a reconstructive hand surgeon may be advised.

- 1) Handle the spray gun carefully. Keep clear of the nozzle. **NEVER** point the gun at yourself or anyone else. **NEVER** permit any part of your body to come in contact with the fluid stream of either the gun or any hose leak. **ALWAYS** keep the gun trigger safety lever in a locked position when not spraying. **ALWAYS** use a tip safety guard.
- 2) **NEVER** attempt to force the flow of fluid backward through the gun with your finger, hand or hand-held object against the gun nozzle. **THIS IS NOT AN AIR SPRAY GUN.**

**PRESSURE RELEASE PROCEDURE**

- A. Set trigger safety in a locked position.**
- B. Shut off pump and unplug electrical cord.**
- C. Release fluid pressure from entire system and trigger gun.**

- 3) **NEVER** attempt to remove tip, disassemble or repair equipment without first doing the following:
  - 4) Before flushing system, always remove spray tip and adjust fluid pressure to lowest possible setting.
  - 5) Tighten all fluid connections before each use. **NEVER** exceed 3200 psi, (221 bar) with this unit. Make sure that all accessory hoses, connections, swivels and so forth can withstand the high pressures which develop. **NEVER** exceed the pressure rating of any component in the system.
  - 6) **WARNING:** The paint hose can develop leaks from wear, kinking, abuse, etc. A leak is capable of injecting fluid into the skin, therefore the paint hose should be inspected before each use. **NEVER** attempt to plug a hose with any part of your body, adhesive tape or any other makeshift device. Do not attempt to repair a spray hose. Instead, replace it with a new grounded hose. Use only with hoses that have spring guards. **NEVER** use less than 50' (15,2m) of hose with this unit.
  - 7) Be sure that the airless equipment being used and the object being sprayed are properly grounded to prevent static discharge or sparks which could cause fire or explosion. **WARNING: ALWAYS** hold the gun against metal container when flushing system with tip removed, to prevent static discharge. **CAUTION:** To reduce the risk of electrical shock, do not expose to rain. Store indoors.
  - 8) **ALWAYS** keep the working area around the pump well ventilated. Additionally, the pump itself should be a minimum of 25' (7,5m) from the spray area. If these instructions are not followed, there is the possibility of fire or explosion with certain materials. **ALWAYS** follow the coating or solvent manufacturer's safety precautions and warnings. Never spray flammable material near open flames, pilot lights or any source of ignition.
  - 9) **ALWAYS** wear spray masks and protective eyewear while spraying. Additional personal protective equipment may be required depending on the type of material being sprayed and conditions of ventilation. Always contact supplier of material being sprayed for recommendation.
- 10) Keep all extension poles clear of electrical wires.
- 11) **NEVER** alter or modify any part of this equipment; doing so could cause it to malfunction.
- 12) **NEVER** leave equipment unattended. Keep away from children or anyone not familiar with the operation of airless equipment.

**NO USE EL EQUIPO ANTES DE LEER ESTA SECCION**

# **ADVERTENCIA**

## **LA ROCIADURA A PRESION ALTA PUEDE CAUSAR LESION GRAVE.**

**Presión de Trabajo Máxima 3200 libras por pulgada cuadrada (psi), 221 bar**

Una pistola rociadora sin aire requiere que se le introduzca líquido a presión muy alta. Los líquidos bajo presión alta, de la rociadura o de las fugas, pueden penetrar en la piel e inyectar en el cuerpo cantidades considerables de líquido tóxico. Si no se atiende rápida y apropiadamente, la lesión puede causar muerte del tejido o gangrena, y puede resultar en incapacidad seria y permanente o en la amputación de la parte lesionada. Por lo tanto, hay que emplear precauciones estrictas al usar cualquier equipo de rociadura sin aire. **SI USTED HA ESTADO EXPUESTO A LA PENETRACION DE TOXICOS POR INYECCION, CONSULTE INMEDIATAMENTE AL MEDICO. ¡NO TRATE LA HERIDA COMO SI FUERA UNA MERA CORTADURA!**

**NOTA PARA EL MEDICO:** La penetración de tóxicos en la piel es una herida seria y traumática. Es importante tratar la herida quirúrgicamente lo más pronto posible. No demore el tratamiento para investigar la toxicidad. La toxicidad es asunto serio cuando se trata de la penetración de ciertos revestimientos tóxicos en la corriente sanguínea. Puede que sea necesaria la consulta con un cirujano plástico o un cirujano especialista en la reconstrucción de la mano.

- 1) Maneje la pistola de rociadura con cuidado. Manténgase alejado de la boquilla. **JAMAS** apunte la pistola hacia usted u otra persona. **NUNCA** permita que parte alguna de su cuerpo se ponga en contacto con el chorro de líquido de la pistola o de alguna fuga de la manguera. **SIEMPRE** mantenga trabado el seguro de la pistola mientras no esté rociando. **SIEMPRE** utilice el protector de seguridad de la boquilla.
- 2) **JAMAS** intente forzar el flujo del líquido por la pistola hacia atrás con el dedo, la mano o un objeto sostenido con la mano contra la boquilla de la pistola, ya que **NO SE TRATA DE UNA PISTOLA DE ROCIADURA DE AIRE.**
- 3) **JAMAS** intente quitar la boquilla ni desarmar o reparar el equipo sin haber cumplido antes con los pasos siguientes:

### **PROCEDIMIENTO DE DESCOMPRESION**

- A. Coloque el seguro de la pistola en posición trabada.**
- B. Apague la bomba y desconecte también el cable de electricidad.**
- C. Descargue la presión del líquido de todo el sistema y de la pistola.**
- D. Vuelva a trabar el seguro.**

- 4) Antes de lavar el sistema, siempre quite la boquilla de rociadura y ajuste la presión del líquido al valor más bajo posible.
- 5) Ajuste todas las conexiones antes de cada uso. **JAMAS** supere 3200 (221 bar) libras por pulgada cuadrada con esta unidad. Asegúrese de que todas las mangueras, conexiones, articulaciones giratorias y demás elementos accesorios estén en condiciones de tolerar las altas presiones que se presentan. **JAMAS** exceda la clasificación de presión de cualquier componente del sistema.
- 6) **ADVERTENCIA:** La manguera de pintura puede presentar fugas como resultado del desgaste, retorcimiento, abuso, etc. Las fugas pueden inyectar líquido a través de la piel, por lo que la manguera de pintura debe ser inspeccionada antes de cada uso. **JAMAS** intente obturar la manguera con una parte de su cuerpo o con tela adhesiva o cualquier otro elemento improvisado. No intente reparar una manguera de rociadura; en cambio reemplácela con una manguera nueva conectada a tierra. Utilice solamente mangueras con protector de resorte. **JAMAS** use una manguera de menos de 15,2 m con esta unidad. Almacenar bajo techo.
- 7) Asegúrese de que el equipo sin aire que esté empleando y el objeto que se intenta rociar estén correctamente conectados a tierra para evitar descargas estáticas o chispas que podrían ocasionar incendio o explosión. **ADVERTENCIA:** Sostenga **SIEMPRE** la pistola contra el receptáculo de metal al limpiar el sistema con la boquilla desprendida, para evitar la descarga estática. **ADVERTENCIA:** Para reducir riesgo de descarga eléctrica, no exponer a la lluvia.
- 8) **SIEMPRE** mantenga el lugar de trabajo alrededor de la bomba bien ventilado. Además, la bomba en sí debe estar ubicada a no menos de 7,6 m de la operación de rociadura. Si no se observan estas instrucciones, existe el riesgo de incendio o explosión con ciertos materiales. **SIEMPRE** observe las precauciones y advertencias de los fabricantes sobre revestimientos y solventes. Nunca rocíe material inflamable cerca de llamas expuestas, llamas piloto o cualquier fuente de ignición.
- 9) **SIEMPRE** use máscaras apropiadas y anteojos de protección durante la operación de rociadura. Según el tipo de material que se está rociando y las condiciones de ventilación puede ser necesario usar equipo personal protector adicional. Siempre comuníquese con el proveedor del material para conseguir recomendaciones.
- 10) Mantenga todas las varas de extensión fuera del alcance de cables eléctricos.
- 11) **JAMAS** altere o modifique parte alguna de este equipo, ya que ello puede causar deficiencias de funcionamiento.
- 12) **JAMAS** deje al equipo solo. Manténgalo fuera del alcance de los niños o de cualquier persona no familiarizada con la operación de equipo sin aire.

**NE PAS UTILISER LE MATERIEL AVANT D'AVOIR LU CETTE SECTION**

# **ATTENTION!**

## **LES PULVERISATEURS A HAUTE PRESSION PEUVENT PROVOQUER DE SERIEUSES LESIONS**

**Pression de travail maximale: 3200 psi — 221 bar**

Le liquide introduit dans un pistolet pulvérisateur sans air doit l'être à pression extrêmement élevée. Les liquides à haute pression, en provenance du pulvérisateur ou d'une fuite quelconque, sont capables de pénétrer la peau et d'injecter d'importantes quantités de liquide toxique dans l'organisme. Si elle n'est pas traitée promptement et avec toute l'attention voulue, la lésion causée de la sorte peut provoquer la nécrose des tissus ou la gangrène et donner lieu à de sérieux handicaps permanents, voire à l'amputation du membre atteint. Une prudence extrême s'impose donc lors de l'utilisation de matériel de pulvérisation sans air. **EN CAS D'INJECTION, CONSULTEZ UN MEDECIN IMMEDIATEMENT. NE TRAITEZ PAS LA BLESSURE COMME S'IL S'AGISSAIT D'UNE SIMPLE COUPURE!**

**REMARQUE A L'INTENTION DU MEDECIN :** Une injection pénétrant la peau constitue une lésion traumatique grave qu'il est important de traiter chirurgicalement aussitôt que possible. Ne perdez pas de temps à rechercher la toxicité de l'injection. Il s'agit là d'un risque à envisager en cas d'injection directe dans le circuit sanguin de certains revêtements exotiques. La consultation d'un chirurgien plasticien ou d'un spécialiste de la chirurgie reconstructive de la main peut être conseillée.

- 1) Maniez le pistolet avec soin. Maintenez-vous à l'écart de la buse. N'en dirigez **JAMAIS** la buse vers aucune partie de votre corps ou vers aucune autre personne. Ne laissez **JAMAIS** aucune partie de votre corps entrer en contact avec le flux de liquide s'échappant du pistolet ou d'une fuite quelconque au niveau du flexible. Verrouillez **TOUJOURS** le levier de sûreté de la détente lorsque vous n'êtes pas occupé à pulvériser. **Veillez à TOUJOURS utiliser un dispositif de sûreté à la buse du pistolet.**
- 2) N'essayez **JAMAIS** de refouler le flux de liquide dans le pistolet au moyen de votre doigt, de votre main ou d'un objet maintenu contre la buse du pistolet. **CET APPAREIL N'EST PAS UN PISTOLET PULVERISATEUR A AIR.** N'utilisez aucune pièce de matériel sans air avec une pompe non équipée d'une soupape de surpression.
- 3) N'essayez **JAMAIS** d'enlever la buse, de démonter ou de réparer l'appareil avant d'avoir accompli la procédure suivante :

### **PROCEDURE DE DELESTAGE DE PRESSION**

- A. Verrouillez la sûreté de la détente.**
- B. Arrêtez la pompe et débranchez le cordon électrique.**
- C. Délestez la pression dans tout le système et appuyez sur la détente du pistolet.**
- D. Reverrouillez la sûreté de la détente.**

- 4) Avant de procéder au rinçage du système, enlevez toujours la buse de pulvérisation et réglez la pression au niveau le plus faible possible.
  - 5) Serrez bien tous les raccords du système hydrodynamique avant chaque emploi. Ne dépassez **JAMAIS**, avec cet appareil, une pression de 3200 psi. Assurez-vous que tous les flexibles accessoires, raccords, articulations, etc. sont bien capables de résister aux hautes pressions prévues. Ne dépassez **JAMAIS** la capacité de pression nominale d'aucun composant du système. **DANGER** Afin de réduire tout risque d'électrocution, n'exposez pas à la pluie.
- ATTENTION** Des fuites risquent de se produire le long du flexible de peinture sous l'effet de l'usure, des torsions, des rudes traitements, etc. auxquels il est éventuellement soumis. Les injections de liquide dans la peau sont possibles par la voie de telles fuites. Il est donc important d'inspecter le flexible avant chaque usage. N'essayez **JAMAIS** d'obturer une fuite à l'aide de votre doigt ou de tout autre membre de votre corps, de ruban adhésif ou de tout autre moyen de fortune. N'essayez pas non plus de réparer un flexible de pulvérisation ; remplacez-le plutôt par un nouveau flexible mis à la terre. Veillez à n'utiliser que les flexibles munis de dispositifs de sécurité à ressort. N'utilisez **JAMAIS** moins de 15,2 m de flexible avec cet appareil.
- 7) Assurez-vous que le matériel sans air utilisé et que l'objet à peindre sont adéquatement mis à la terre, de façon à éviter toute décharge d'électricité statique ou toute étincelle susceptible de provoquer un incendie ou une explosion. **ATTENTION** Tenez **TOUJOURS** le pistolet contre un récipient en métal lors du rinçage du système, après en avoir ôté la buse. Ne vaporisez **JAMAIS** de substances inflammables à proximité de flammes nues, lampes témoin ni d'aucune source d'allumage. Rangez à l'intérieur.
  - 8) Le moteur électrique de cet appareil n'est pas protégé contre les explosions. Il est donc essentiel d'assurer une bonne ventilation de la zone de travail et des alentours de la pompe. Il est également important de maintenir la pompe à une distance minimale de 7,6 m de la zone de pulvérisation. Certains matériaux présentent, à défaut de suivre ces consignes, un risque d'incendie ou d'explosion. Suivez **TOUJOURS** les précautions et avertissements du fabricant de chaque solvant ou revêtement utilisé.
  - 9) Portez **TOUJOURS** un masque et des lunettes de protection lors de vos travaux de pulvérisation. D'autres articles de protection personnelle peuvent être nécessaires suivant le type de produit pulvérisé et les conditions d'aération. Demandez toujours ses recommandations à votre fournisseur.
  - 10) Maintenez toutes les tiges de rallonge à distance des fils électriques.
  - 11) N'altérez ou ne modifiez **JAMAIS** une partie quelconque de cet appareil, ce qui pourrait causer des défaillances.
  - 12) Ne laissez **JAMAIS** le matériel sans surveillance. Gardez-le hors de portée des enfants et de toute personne inexpérimentée quant à l'usage de matériel sans air.

# FIRE OR EXPLOSION HAZARD

Static electricity is created by the high velocity of fluid through the pump, hose and tip. If every part of the spray element is not properly grounded, sparking may occur and the system may become hazardous. Sparking may also occur when plugging in or unplugging a power supply cord, or starting a gas engine. Sparks can ignite fumes from solvents or the fluids being sprayed. Always plug the sprayer into an outlet at least 25' (7,5m) away from the spray area. **WARNING: Always flush the unit into a separate metal container with the spray tip removed and the gun held firmly against the side of the container to assure proper grounding and prevent static discharge which could cause serious bodily injury.**

If you experience any static sparking or slight shock while using this equipment, stop spraying immediately. Check the entire system for proper grounding. Do not use the system again until the problem has been corrected.

## ELECTRIC MOTOR

The electric motors used by TITAN are not explosion proof. Therefore, it is essential to keep the working area around the pump well ventilated. Additionally, the pump itself should be a minimum of 25' (7.5m) from the spray area. **WARNING: Always keep pump outside of any enclosed spray area. Never clean the exterior of the pump with any flammable solvents.**

## GAS ENGINE

Always keep pump outside of any enclosed spray area. Keep area around pump well ventilated. Keep all solvents away from engine exhaust. (Never fill the fuel tank while the engine is running or hot. Fuel spilled on a hot surface can ignite and cause a fire.) Always attach ground wire located on rear of engine to a grounded object, i.e. water pipe. **NOTE: Refer to engine owner's manual for additional safety and service information.**

## FLUID SECTION—SOLVENTS

Halogenated Hydrocarbon solvents can cause an explosion when used with aluminum or galvanized components in a closed (pressurized) fluid system (pumps, heaters, filters, valves, spray guns, tanks, etc.). The explosion could cause serious injury, death and/or substantial property damage. Cleaning agents, coatings, paints, etc. may contain Halogenated Hydrocarbon solvents. Titan Tool Inc. spray equipment includes aluminum or galvanized components and will be affected by Halogenated Hydrocarbon solvents. **DO NOT USE HALOGENATED HYDROCARBONS IN TITAN EQUIPMENT.**

## EXPLANATION OF THE HAZARD

There are three key elements to the Halogenated Hydrocarbon (HHC) solvent hazard. These elements are:

1. **The presence of HHC solvents.**
2. **Aluminum or galvanized parts.**
3. **Equipment capable of withstanding pressure.**

When all three elements are present, the result can be an extremely violent explosion. The reaction can be sustained with very little aluminum or galvanized metal: any amount of aluminum is too much. The reaction is unpredictable. Prior use of an HHC solvent without incident (corrosion or explosion) does NOT mean that such use is safe.

# PELIGRO DE INCENDIO O EXPLOSIÓN

La alta velocidad del líquido a través de la bomba, manguera y la boquilla produce electricidad estática. Si algún componente del equipo de rociadura no está conectado a tierra correctamente pueden producirse chispas y el sistema se vuelve peligroso. También pueden producirse chispas al enchufar o desenchufar cables eléctricos o al poner en funcionamiento un motor a gasolina. Las chispas pueden encender los vapores provenientes de los solventes o de los líquidos rociados. Siempre conecte el rociador a un enchufe ubicado a no menos de 7,5m de distancia de la zona de rociadura. **ADVERTENCIA: Lavar siempre la unidad en un recipiente metálico separado, habiendo quitado la boca del rociador y teniendo la pistola firmemente contra el lado del recipiente para asegurar una puesta a tierra correcta y evitar la descarga estática que podría causar lesión corporal grave.**

Si ocurren chispas de electricidad estática o si sufre un shock eléctrico ligero mientras usa el equipo, deje de rociar de inmediato. Verifique que el sistema en su totalidad esté conectado a tierra correctamente. No vuelva a usar el sistema hasta que el problema haya sido resuelto.

## MOTOR ELÉCTRICO:

Los motores eléctricos utilizados por TITAN no son a prueba de explosión. Por lo tanto, es esencial mantener el área de trabajo alrededor de la bomba bien ventilada. Además, la bomba misma debe estar a una distancia mínima de 7.5 m del área de rociadura. **ADVERTENCIA: Mantener siempre la bomba afuera de cualquier área de rociadura cerrada. Nunca limpie el exterior de la bomba con solventes inflamables.**



## **MOTOR A GASOLINA: (Si fuera aplicable)**

Siempre mantenga la bomba afuera de cualquier zona de rociadura cerrada. Mantenga el área alrededor de la bomba bien ventilada. Mantenga todos los solventes lejos del escape del motor. (Nunca liene el tanque de combustible cuando el motor esté funcionando o caliente. El combustible derramado sobre una superficie caliente puede encenderse y producir un incendio). El cable a tierra que está ubicado en la parte de atrás del motor debe estar siempre adherido a un objeto conectado a tierra, por ejemplo, una cañería de agua. **NOTA:** Vea el manual de uso del motor para información adicional sobre seguridad y mantenimiento.

## **SECCION FLUIDO—SOLVENTES**

Los solventes a base de hidrocarburos halogenados pueden provocar explosión cuando se usan con componentes galvanizados o de aluminio en un sistema líquido cerrado (sujeto a presión) (bombas, calefactores, filtros, válvulas, pistolas de rociadura, tanques, etc.) La explosión podría causar lesiones serias e inclusive la muerte, así como daños materiales de consideración. Los líquidos de limpieza, revestimientos, pinturas, etc. pueden contener solventes a base de hidrocarburos halogenados. El equipo de rociadura ofrecido por Titan Tool Inc. tiene componentes galvanizados o de aluminio y será afectado por solventes a base de hidrocarburos halogenados. **NO USE HIDROCARBUROS HALOGENADOS EN EL EQUIPO TITAN.**

## **EXPLICACION DEL RIESGO**

Hay tres elementos fundamentales que condicionan el riesgo de los hidrocarburos halogenados, a saber:

- 1. Presencia de solventes de hidrocarburos halogenados.**
- 2. Componentes galvanizados o de aluminio.**
- 3. Equipo capaz de tolerar presión.**

Cuando todos estos elementos están presentes, el resultado puede ser una explosión sumamente violenta. La reacción puede tener lugar aun cuando la cantidad de aluminio o metal galvanizado sea muy pequeña: cualquier cantidad de aluminio es excesiva. La reacción no puede predecirse. El hecho de que un solvente a base de hidrocarburos halogenados haya sido usado anteriormente sin accidentes (corrosión o explosión) **NO** significa que dicho uso no es peligroso.

# **DANGER!**

## **RISQUE D'INCENDIE OU D'EXPLOSION**

La vitesse du liquide à travers la pompe le flexible et la buse produit de l'électricité statique. Si tous les éléments du matériel de pulvérisation ne sont pas mis à la terre de manière adéquate, ils risquent de favoriser la production d'étincelles et de rendre le système dangereux. Des étincelles peuvent également se produire lors de branchement ou débranchement d'un cordon d'alimentation électrique ou lors de la mise en marche d'un moteur au gaz. De telles étincelles sont susceptibles d'enflammer les vapeurs des solvants ou les liquides pulvérisés. Veillez donc toujours à brancher le pulvérisateur dans une prise située à au moins 7,5 m du pulvérisateur et de la zone de travail. **MISE EN GARDE: Toujours rincer l'appareil dans un récipient métallique distinct après avoir enlevé le bec de pulvérisation et en tenant fermement le pistolet contre le côté du récipient afin d'assurer une mise à la terre appropriée et de prévenir une décharge statique susceptible de causer des blessures graves.**

Si vous remarquez la formation d'étincelles sous l'effet de la présence d'électricité statique ou que vous ressentez une légère décharge électrique en cours d'utilisation du matériel, arrêtez immédiatement la pulvérisation. Assurez-vous que tous les éléments du système sont bien mis à la terre. Ne remettez pas le système en marche avant d'avoir résolu le problème.

## **MOTEUR ÉLECTRIQUE**

Les moteurs électriques utilisés par TITAN ne sont pas protégés contre les explosions. Il est donc essentiel d'assurer une bonne ventilation de la zone de travail et des environs de la pompe. Il est également important de maintenir la pompe à une distance minimale de 7,5 m de la zone de pulvérisation. **ATTENTION: N'introduisez jamais la pompe dans une zone de pulvérisation fermée. Ne nettoyez jamais nettoyer l'extérieur de la pompe à l'aide de solvants inflammables.**

## **MOTEUR AU GAZ (le cas échéant)**

N'introduisez jamais la pompe dans une zone de pulvérisation fermée. Veillez à ce que les environs de la pompe soient toujours bien aérés. Ne placez aucun solvant à proximité du système d'échappement du moteur. (Ne remplissez jamais le réservoir à carburant lorsque le moteur tourne ou s'il est chaud. Renversé sur une surface chaude, le gaz pourrait s'enflammer et provoquer un incendie.) Veillez à toujours bien raccorder le fil de terre situé à l'arrière du moteur à un objet mis à la terre (par exemple, une conduite d'eau). **REMARQUE: Pour plus de détails sur les mesures de sécurité et d'entretien pertinentes, consultez le manuel fourni avec le moteur.**

## **SECTION HYDRODYNAMIQUE—SOLVANTS**

Les solvants à hydrocarbure halogéné sont explosifs en présence de pièces galvanisées ou en aluminium dans un système hydrodynamique fermé (pressurisable) (pompes, radiateurs, filtres, soupapes, pistolets pulvérisateurs, réservoirs, etc.) L'explosion provoquée pourrait donner lieu à des lésions corporelles graves ou même mortelles et/ou à de sérieux

dégâts matériels. Certains produits d'entretien, revêtements, peintures et autres liquides contiennent des solvants à hydrocarbure halogéné. Les appareils pulvérisateurs de la Titan Tool Inc. comportent des pièces en aluminium et des composants galvanisés sensibles aux solvants à hydrocarbure halogéné. **N'EMPLOYER PAS D'HYDROCARBURES HALOGÉNÉS DANS LE MATÉRIEL TITAN.**

## EXPLICATION DU RISQUE

Le danger que présentent les solvants à hydrocarbure halogéné se caractérise par trois éléments clés:

1. **La présence de solvants à hydrocarbure halogéné**
2. **La présence de pièces en aluminium ou galvanisées**
3. **Un matériel capable de supporter des pressions élevées**

La combinaison de ces trois éléments peut donner lieu à une explosion extrêmement violente. La réaction peut se produire en présence d'une quantité minimale d'aluminium ou de métal galvanisé. En fait, la moindre trace d'aluminium en constitue déjà trop.

La réaction est imprévisible. Toute utilisation antérieure de solvant à hydrocarbure halogéné n'ayant donné lieu à aucun incident (corrosion ou explosion) NE CONSTITUE NULLEMENT un signe de sécurité.

## HALOGENATED SOLVENTS

**DEFINITION -- Any hydrocarbon solvent containing any of the elements as listed below:**

Consult your material supplier to determine whether your solvent or coating contains Halogenated Hydrocarbon Solvents.

## SOLVENTES HALOGENADOS

**DEFINICION -- Cualquier solvente a base de hidrocarburos que contenga cualquiera de estos elementos:**

EJEMPLOS (lista parcial):

Consulte la información suministrada por su proveedor de materiales para determinar si un solvente o revestimiento contiene solventes de Hidrocarburos Halogenados.

## SOLVANTS HALOGÉNÉS

**DÉFINITION -- Tout solvant à hydrocarbure contenant l'un des éléments suivants:**

EXEMPLES (liste incomplete):

Pour déterminer si vos solvants ou revêtements contiennent des solvants à hydrocarbure halogéné, consultez votre fournisseur.

**Fluorine (F) "-fluor-"**      **Chlorine (Cl) "-chloro-"**  
**Bromine (Br) "-bromo-"**      **Iodine (I) "-Iodo-"**

### EXAMPLES

(not all-inclusive):

#### FLUOROCARBON SOLVENTS:

Dichlorofluoromethane

Trichlorofluoromethane

#### BROMINATED SOLVENTS:

Ethylene dibromide

Methylene chlorobromide

Methyl bromine

#### IODINATED SOLVENTS:

N-butyl iodide

Methyl iodide

Ethyl iodide

Propyl iodide

#### CHLORINATED SOLVENTS:

Carbon tetrachloride

Chloroform

Ethylene dichloride

#### METHYLENE CHLORIDE or

DICHLOROMETHANE

Monochlorobenzene

Orthodichlorobenzene

Perchloroethylene

#### TRICHLOROETHANE

Trichloroethylene

Monochlorotoluene

## START-UP PROCEDURE

**WARNING:** High pressure device, thoroughly read and understand the warning section located in the owner's manual and the label on the sprayer.

**IMPORTANT:** Whenever starting or cleaning this sprayer, always reduce engine or motor speed. Additionally, never operate this sprayer for more than 10 seconds without fluid, this can cause unnecessary wear to the packings.

**Do not operate dry.**

**Step 1:** Before you plug in the power cord to the electrical outlet or start the gas engine, do the following:

- A. Tighten suction and return hoses, then install a minimum of 50' (15m) of nylon airless spray hose and airless gun. Do not install tip yet, or remove if installed. **WARNING:** If you are supplying your own hoses and spray gun, be sure they are electrically grounded and rated for at least 3200 psi (221 bar) working pressure, and that the gun has a tip guard. This is to reduce the risk of serious bodily injury caused by static sparking and fluid injection or overpressurization, causing a component rupture.

- B. Preset pressure control by turning the pressure control knob counterclockwise to lowest setting.
- C. Place on-off switch in the off position.
- D. Be sure to fill the Wet Cup with 1 tablespoon Piston Seal Lubricant.

**Step 2E: ELECTRIC MOTOR**

- A. Check electrical service. Be sure it is 120V 15 amp minimum and that outlet is properly grounded.
- B. Plug electrical cord into a grounded outlet that is at least 25' (7,5m) from the spray area. **Make certain that all extension cords are a three wire, 12 gauge minimum cord with a grounded plug. Never remove third prong or use an adaptor. Never exceed 150' (45m) of extension cord.**
- C. If a secondary hose and gun is not installed be sure the plug is secure.
- D. Place the suction tube into container containing mineral spirits.

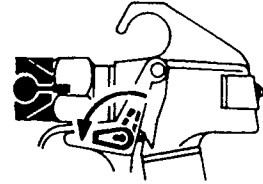

Lock position

**Step 2G: GAS ENGINE (Where Applicable)**

- A. **Check the engine oil level.** For instructions refer to the engine manual supplied.
- B. **Fill the gas tank.** Be sure the engine is cool. Refueling a hot engine could cause a fire. Close the black fuel shut off lever located under the air cleaner. **Use unleaded high quality gasoline.**
- C. If a secondary hose and gun is not installed, be sure the plug is secure.
- D. Place the suction tube into container containing mineral spirits.
- E. Open the fuel shut off lever by pushing it in the direction of the arrow.
- F. Move the throttle lever away from fuel tank.
- G. Close the engine choke lever, located beneath the air cleaner.
- H. Turn the engine switch on. Turn pressure relief prime valve down to prime position.
- I. Pull the starter rope. Holding the frame with one hand, pull the rope rapidly and firmly. Continue to hold the rope as you let it return. Pull and return rope until engine starts.

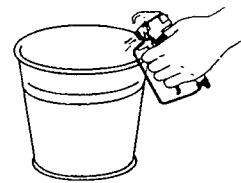

Remove Tip and Safety Guard when flushing

**Step 3:** Flush oil out of new paint pump: Oil is used by the factory for testing and protection. It is necessary to flush out with mineral spirits before you begin to spray.

- A. Pour 1/2 gallon mineral spirits into a metal container and insert syphon and return tube.
- B. Turn pressure relief prime valve down to prime position and turn unit on. Increase pressure slightly. Let solvent cycle for approximately 30 seconds. Then tilt syphon tube above container and let the sprayer pump itself dry. Then turn unit off. If you are going to use water based paints, repeat procedure using water.

**Step 4:** Prepare the paint according to manufacturer's recommendations. Remove any skin that may have formed and stir. Strain the paint through a fine nylon mesh bag to remove particles that could clog spray tip.

**Step 5:** Place syphon and return tubes into paint container. Turn pressure relief priming knob, located on side of pump, down for priming.

**Step 6:** Turn sprayer on and turn up pressure slightly. Let circulate on prime until no bubbles filter up through the paint.

**Step 7:** Hold gun firmly against a metal container, disengage trigger lock and trigger gun against side of container. Then, while gun is triggered, turn the pressure relief valve to the spray position. Keep the gun triggered until all the air is forced out of the system and the paint flows freely. Release the trigger and engage gun safety lock; set gun down while unit pressurizes.

**Step 8:** Check for leaks. If any leaks occur, follow the proper pressure relief procedure before tightening.

**Step 9:** Turn off sprayer and relieve pressure by turning pressure relief prime knob to prime.

**Step 10:** With gun trigger lock engaged, install tip and guard as instructed in separate tip or gun manual.

**Step 11:** Turn sprayer on and rotate the pressure relief prime valve to the spray position.

**Step 12:** Test on cardboard to check spray pattern. Adjust pressure just until the spray from gun is completely atomized.

# APPLICATION TECHNIQUES

The following techniques, if followed, will assure professional painting results.

Hold the gun perpendicular to the surface and always at equal distance from the surface. Depending on the type of material, surface or desired spray pattern, the gun should be held at a distance of 12 to 14 inches (30 to 35 cm).

Move the gun either across or up and down the surface at a steady rate. Moving the gun at a consistent speed conserves material and provides even coverage. The correct spraying speed allows a full wet coat of paint to be applied without runs or sags.

Holding the gun closer to the surface deposits more paint on the surface and produces a narrower spray pattern. Holding the gun farther from the surface produces a thinner coat and wider spray pattern. If runs, sags or excessive paint occur, change to a spray tip with a smaller orifice. Conversely, if there is an insufficient amount of paint on the surface or you desire to spray faster, a larger orifice tip should be selected.

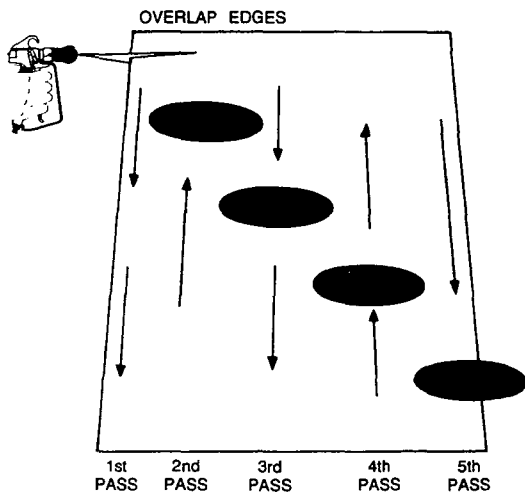

For corners and edges, split the center of the spray pattern on the corner or edge and spray vertically so that both adjoining sections receive approximate even amounts of paint

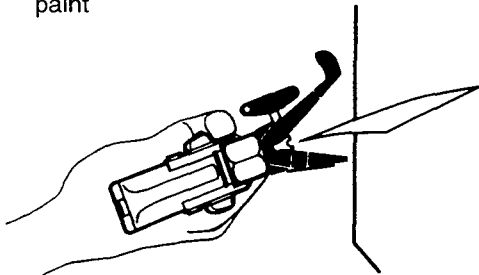

**When spraying with a shield**, hold it firmly against the surface. Angle the spray gun slightly away from the shield and toward the surface. This will prevent paint from being forced underneath.

**Shrubs next to houses should be tied back** and covered with a canvas cloth. The cloth should be removed as soon as possible. Titan Gun Extensions are extremely helpful in these situations.

**Nearby objects such as automobiles, outdoor furniture, etc. should be moved or covered** whenever in the vicinity of a spray job. Be careful of any other surrounding objects that could be damaged by overspray.

## Proper Technique

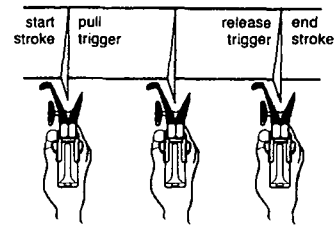

Maintain uniform spray stroke action. Spray alternately from left to right and right to left. Begin movement of the gun before the trigger is pulled.

## Wrong Technique

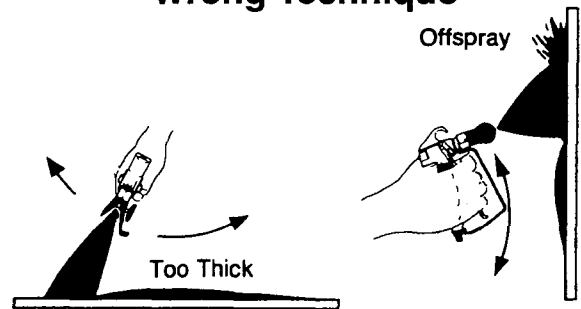

Avoid arcing or holding the gun at an angle. This will result in an uneven finish.

**PROPER LAPPING** (overlap of spray pattern) is essential to an even finish. Lap each stroke. If you are spraying horizontally, aim at the bottom edge of the preceding stroke, so as to lap the previous pattern by 50%.

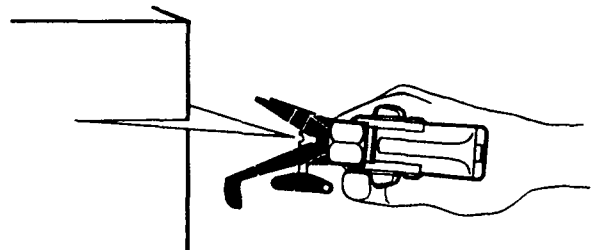

If conditions are windy, angle the spray pattern into the wind to minimize drifting. Work from ground to roof. Do not attempt to spray if wind is excessive.

## Cleaning Procedure

**WARNING: High pressure device – Follow all safety warnings located on sprayer and in the owner's manual. Always clean using low pressure, with the spray tip removed. Always flush into a separate metal container away from the sprayer. Never clean the exterior of the pump while the pump is plugged in or operating.**

### PRESSURE RELEASE PROCEDURE:

**Step 1:** Engage trigger safety lock on gun.

**Step 2:** Turn off pump and release fluid pressure by turning the pressure relief prime valve located on the side of pump down.

### LOW PRESSURE CLEANING PROCEDURE:

**Step 3:** Remove tip and let soak clean, in a small container of solvents or water. Adjust fluid pressure to lowest possible setting.

**Step 4:** Turn the pump on. Tilt syphon tube above paint container, allowing the sprayer to pump itself dry through the return tube.

**Step 5:** Have available container of hot soapy water if spraying latex (or suitable solvent for oil base paints). Do not clean with mineral spirits if using latex paint as this will make jelly.

**Step 6:** Place syphon tube into container with hot soapy water or solvents. Let circulate for 2-3 minutes, then turn unit off.

**Step 7:** To save paint still in spray hose, turn prime valve up to spray position, then carefully trigger gun into and against side of metal paint container. Be careful of splashing. When cleaning solution appears, shut off gun and place gun in a separate metal container. Repeat process if spraying with two guns.

**Step 8:** Trigger gun and let cleaning solution circulate for approximately 2-3 minutes, then turn unit off.

**Step 9:** Turn prime valve down and remove suction tube from cleaning container. Turn unit on and allow sprayer to pump dry.

**Step 10:** Take a clean container of water or solvent and using low pressure pump through system until clear. If cleaning with water, pump a small amount of mineral spirits or TITAN LS-10 solution through pump. This will protect against corrosion.

**Step 11:** Take suction tube out of container and let sprayer run itself dry.

**Step 12:** Check filter on pump and gun. Clean or replace.

**Step 13:** Remove spray tip from solvent, clean with a soft bristle brush and store in a dry place.

## TROUBLESHOOTING AIRLESS GUN

PROBLEM	PROBABLE CAUSE	REMEDY
Spitting gun	1. Air in system 2. Dirty gun 3. Needle assembly out of adjustment 4. Broken or chipped seat	1. Inspect connections for air leaks 2. Disassemble and clean 3. Inspect and adjust 4. Inspect and replace
Gun will not shut off	1. Worn or broken needle & seat 2. Needle assembly out of adjustment 3. Dirty gun	1. Replace 2. Adjust 3. Clean
Gun does not spray	1. No paint 2. Plugged filter or tip 3. Broken needle in gun	1. Check fluid supply 2. Clean 3. Replace

## TROUBLESHOOTING SPRAY PATTERNS

PROBLEM	PROBABLE CAUSE	REMEDY
Tails	1. Inadequate fluid delivery 2. Fluid not atomizing 3. Insufficient velocity 4. Material too cohesive 5. Tip worn past pump capacity	1. Increase pressure 2. Change to smaller tip 3. Clean gun & pump filters 4. Reduce viscosity 5. Replace
Heavy centered pattern	1. Worn tip 2. Tip may be chipped	1. Replace 2. Replace
Distorted pattern	1. Plugged, worn or chipped tip	1. Clean or replace
Pattern expanding and contracting (Surge)	1. Leak in suction tube 2. Not enough hose 3. Tip too large or worn	1. Tighten 2. Use a minimum of 50' (15m) of 1/4" high pressure hose 3. Replace with a new or smaller tip

## AIRLESS TIP SELECTION

Tips are selected by the orifice size and fan width. The proper selection is determined by the fan width required for a specific job and by the orifice size that will supply the desired amount of fluid and accomplish proper atomization.

For light viscosity fluids, smaller orifice tips generally are desired. For heavier viscosity materials, larger orifice tips are preferred. Please refer to the chart below.

**Note: do not exceed the pump's recommended tip size.**

The following chart indicates the most common sizes and the appropriate materials to be sprayed.

<b>.011 - .013</b>	Lacquers & Stains	100 Mesh Filter
<b>.015 - .019</b>	Oil & Latex	50 Mesh Filter
<b>.021 - .026</b>	Heavy Bodied Latex & Blockfillers	5 Mesh Filter

Fan widths measuring 8" to 12" (20 to 30 cm) are most preferred because they offer more control while spraying and are less likely to plug.

## Flushing Specifications

**1. New Sprayer:** Oil is used by the factory for testing and protection. It is necessary to flush unit before spraying.

A. If spraying water-base paint, flush with mineral spirits followed by water.

B. If spraying oil-base paint, flush with mineral spirits only.

**2. Changing from water-base to oil base:** Flush with water, then mineral spirits.

**3. Changing from oil-base to water-base:** Flush with mineral spirits, then water.

**4. Changing colors:** Flush with a compatible solvent such as water or mineral spirits.

**5. Storage:** To assure proper performance and long life, always clean the sprayer thoroughly before storing.

**A. Water-Base Paint:** Flush with water, then mineral spirits and leave the pump, gun and hose filled with mineral spirits. Shut off and unplug the sprayer and turn pressure relief prime valve to prime to relieve pressure. Return prime valve to spray position.

**B. Oil-Base Paint:** Flush with mineral spirits. Shut off and unplug the sprayer, turn the pressure relief prime valve to prime to relieve pressure and leave open. Return prime valve to spray position.

• During storage the power cord must be coiled around cord holder to avoid damage.

### 6. Start-Up After Storage:

**A. Water-Base Paint:** Flush out mineral spirits with water.

**B. Oil-Base Paint:** Flush out the mineral spirits with the material to be sprayed.

Always dispose of mineral spirits in a proper way.

## TROUBLESHOOTING AIRLESS PUMP

PROBLEM	PROBABLE CAUSE	REMEDY
Electric motor won't run	<ol style="list-style-type: none"> <li>1. Unit unplugged or circuit fuse blown</li> <li>2. Pressure setting too low</li> <li>3. Brushes on motor are worn</li> <li>4. Electric motor burned out</li> <li>5. Switch defective</li> <li>6. Fuse in pump blown</li> </ol>	<ol style="list-style-type: none"> <li>1. Check</li> <li>2. Increase</li> <li>3. Replace</li> <li>4. Replace</li> <li>5. Replace</li> <li>6. Replace</li> </ol>
Gas engine won't start (where applicable)	<ol style="list-style-type: none"> <li>1. Engine switch not on</li> <li>2. Engine oil level low</li> <li>3. Out of gas</li> <li>4. Spark plug cable disconnected or bad plug</li> </ol>	<ol style="list-style-type: none"> <li>1. Turn on</li> <li>2. Try starting engine. If light on rear glows, add oil</li> <li>3. Fill</li> <li>4. Connect or replace</li> </ol>
Pump won't prime	<ol style="list-style-type: none"> <li>1. Air in line</li> <li>2. Insufficient pressure</li> <li>3. Clutch worn or damaged (Gas models)</li> </ol>	<ol style="list-style-type: none"> <li>1. Check syphon tube O-Ring and/or let paint circulate in prime position</li> <li>2. Increase pressure</li> <li>3. Replace</li> </ol>
Insufficient material flow	<ol style="list-style-type: none"> <li>1. No paint</li> <li>2. Syphon strainer clogged</li> <li>3. Pump/gun filter clogged</li> <li>4. Pump will not prime, material too heavy</li> <li>5. Engine not tuned properly (Gas)</li> <li>6. Worn clutch (Gas models)</li> </ol>	<ol style="list-style-type: none"> <li>1. Check supply</li> <li>2. Clean</li> <li>3. Clean &amp; replace</li> <li>4. Thin material</li> <li>5. Tune engine</li> <li>6. Service</li> </ol>
Pump will not maintain pressure	<ol style="list-style-type: none"> <li>1. Air leak in system</li> <li>2. Air leak in syphon tube</li> <li>3. Inlet valve not seating</li> <li>4. Worn packings</li> <li>5. Dirty or worn ball valves</li> <li>6. Worn valve seats</li> <li>7. Worn prime valve</li> </ol>	<ol style="list-style-type: none"> <li>1. Tighten connections</li> <li>2. Tighten, check for leaks</li> <li>3. Service or clean</li> <li>4. Replace</li> <li>5. Clean or replace</li> <li>6. Reverse</li> <li>7. Replace</li> </ol>
Not enough pressure	<ol style="list-style-type: none"> <li>1. Pressure setting too low</li> <li>2. Plugged filters</li> <li>3. Spray tip too big or worn</li> <li>4. Engine or motor rpm too low (Gas)</li> </ol>	<ol style="list-style-type: none"> <li>1. Increase</li> <li>2. Clean or replace</li> <li>3. Change or replace</li> <li>4. Increase throttle</li> </ol>
Excessive surge at spray gun --	<ol style="list-style-type: none"> <li>1. Wrong type of hose</li> <li>2. Spray tip too big or worn</li> <li>3. Excessive pressure</li> </ol>	<ol style="list-style-type: none"> <li>1. Replace with a minimum 50' grounded nylon braid high pressure hose</li> <li>2. Change or replace</li> <li>3. Decrease pressure and engine speed</li> </ol>
Paint leaks into oil cup	<ol style="list-style-type: none"> <li>1. Worn out packings</li> </ol>	<ol style="list-style-type: none"> <li>1. Replace</li> </ol>

### Frame Assembly (Frame Complete 783-010)

ITEM NO	PART NO	DESCRIPTION	QTY
1	590-502	Handle	1
2	590-508	Roll Pin	2
3	590-507	Snap Button	2
4	590-504	Sleeve	2
5	590-506	Washer	2
6	856-921	Screw	4
7	856-002	Washer	4
8	449-120	Spacer	1
9	590-503	Axle	1
10	783-007	Pump Support	1
11	756-094	Lock Washer	4
12	756-154	Screw	4
13	870-004	Washer	2
14	570-010	Cotter Key	2
15	670-109	Wheel	2
16	449-145	Spacer	1
17	781-030	Frame	1
18	756-090	Washer	4

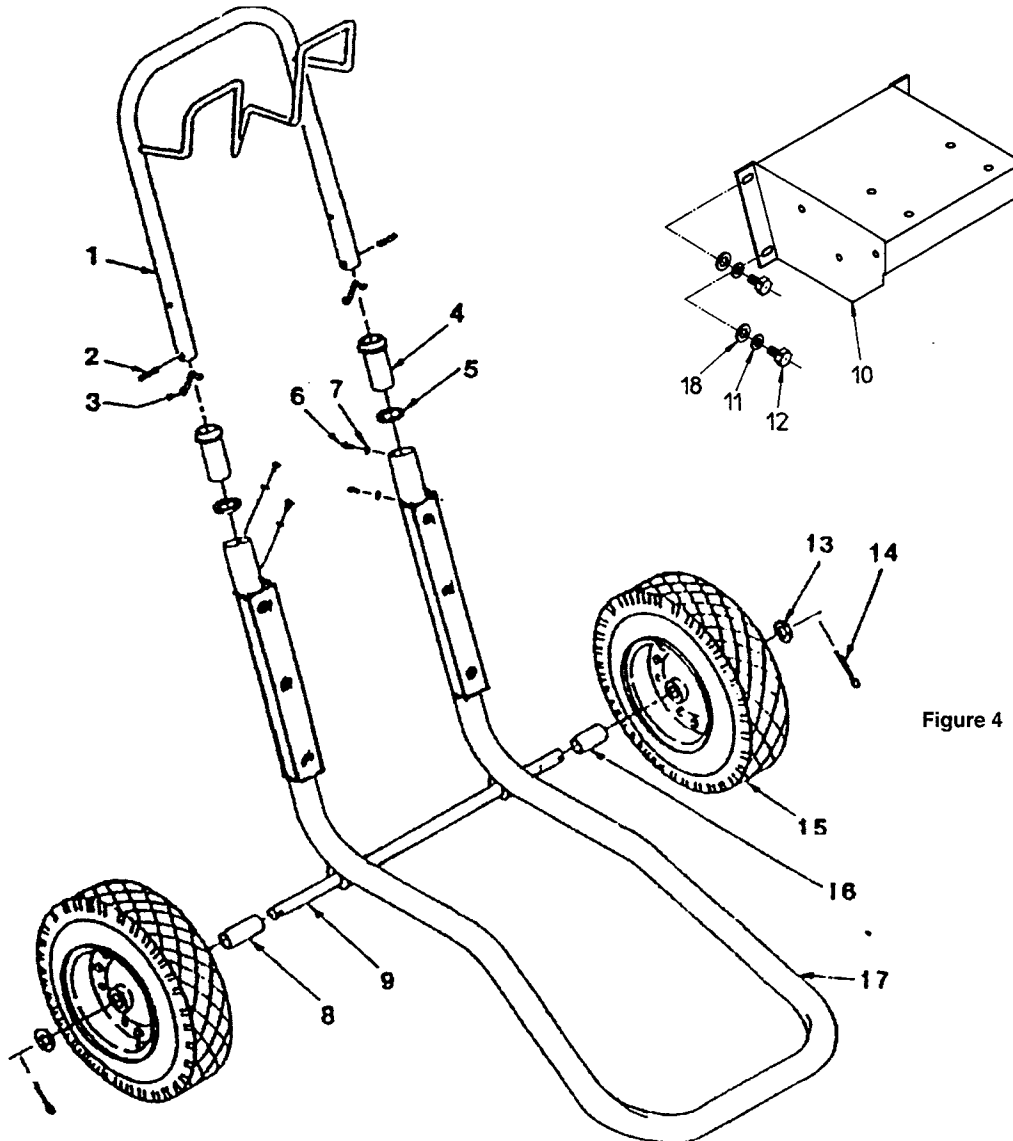

Figure 4

# TITAN

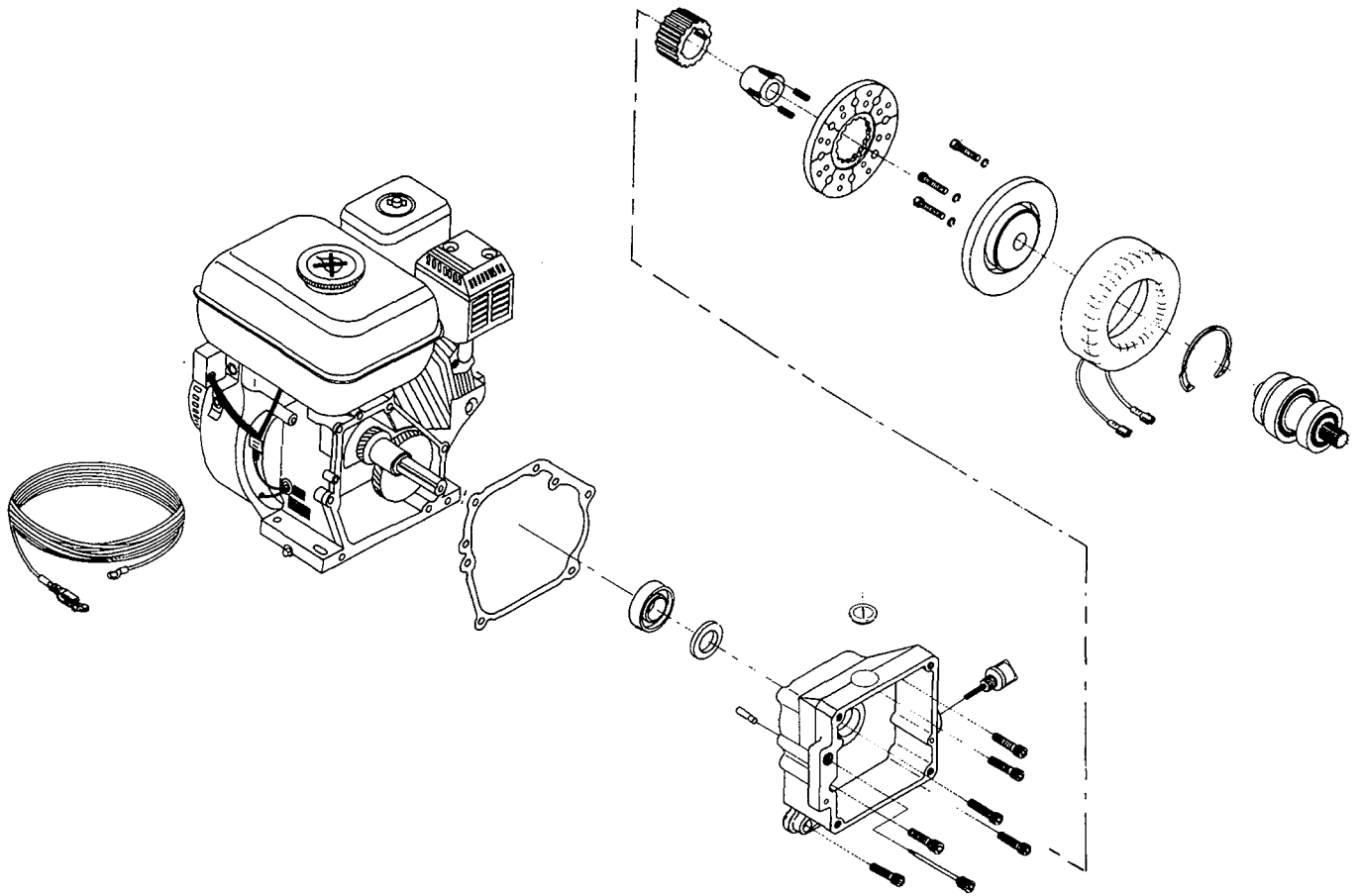

Figure 5

## Replacement Labels

ITEM NO	PART NO	DESCRIPTION	QTY
1	313-1232	Gas Tank	1
2	782-050	Front Cover	1
3	313-191	"Warning" Label, English	1
4	313-201	"Warning" Label, French	1



# Epic 1200HPG

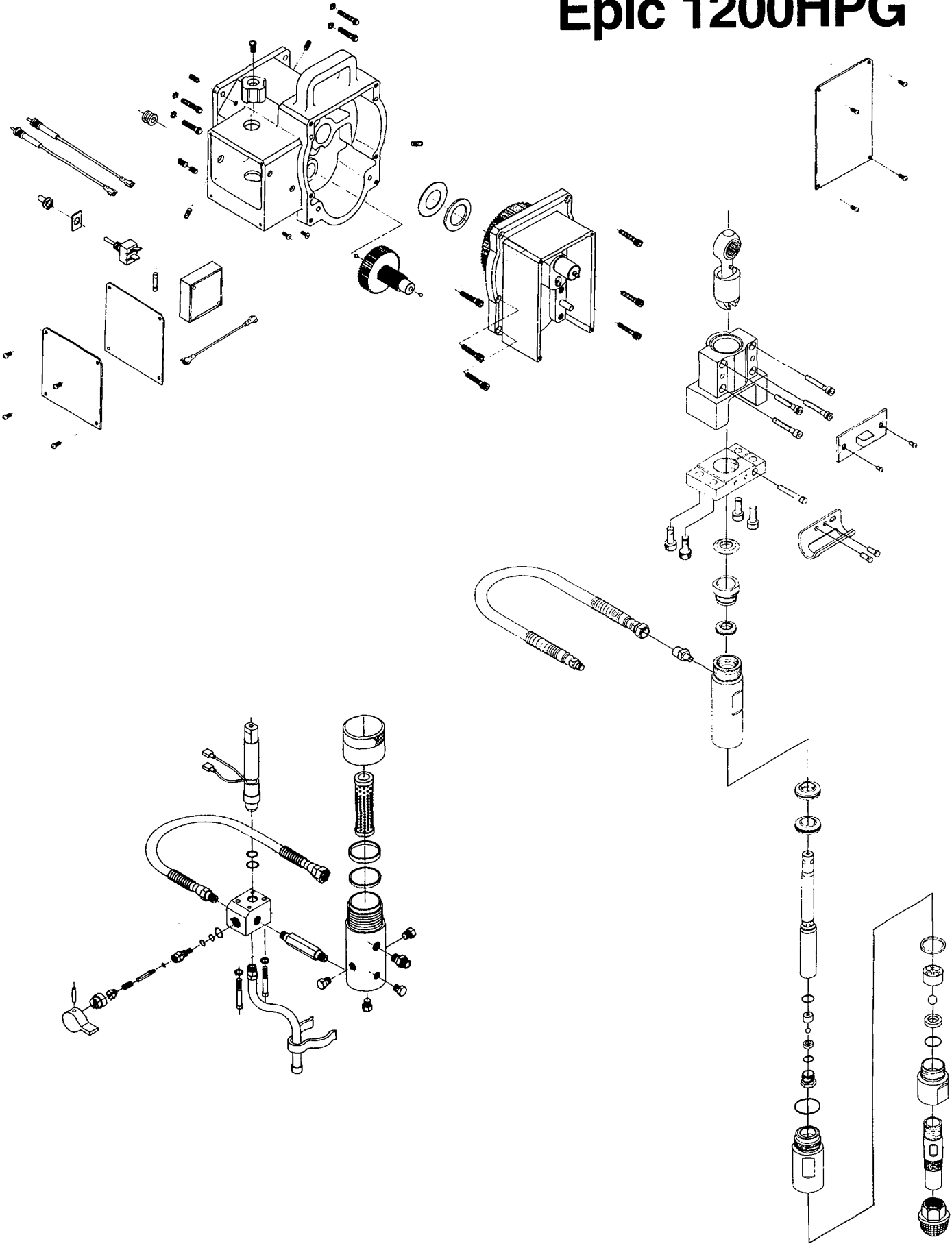

# Engine

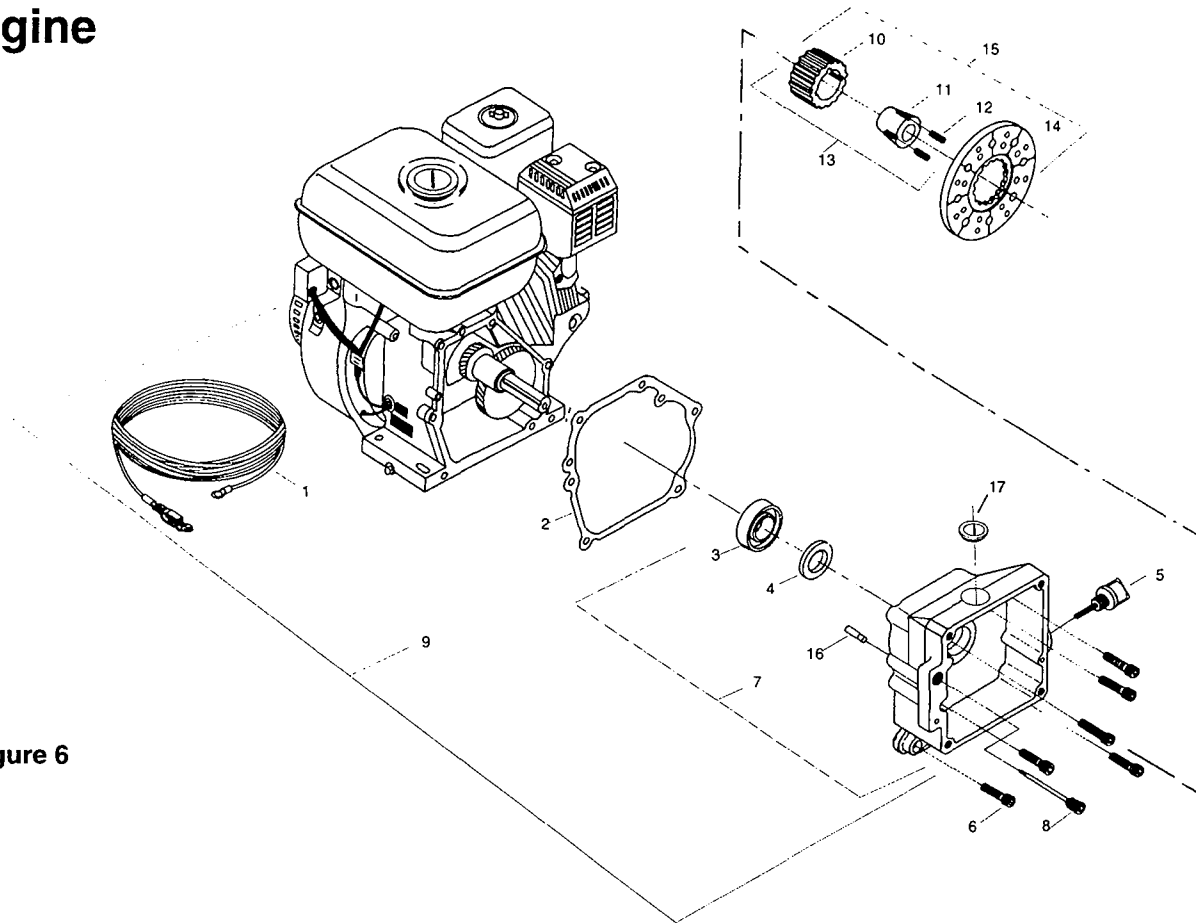

Figure 6

ITEM NO	PART NO	DESCRIPTION	QTY
1	730-165	Ground Wire	1
2	730-162	Gasket	1
3	730-161	Engine Bearing	1
4	730-160	Engine Seal	1
5	730-158	Dip Stick	1
6	763-524	Screw	6
7	784-056	Engine Mount (Incl. 3 & 4)	1
8	730-184	Electrical Connector	1
9	763-535	Engine Assembly (Includes #1-8 & #16)	1
10	763-520	Spline	1
11	763-550	Bushing (Incl. #12)	1
12	763-566	Screw	2
13	763-565	Spline Assembly (Includes #10-12)	1
14	763-521	Clutch Plate	1
15	763-567	Clutch Assembly (Includes #10-14)	1
16	700-722	Terminal	1
17	764-018	Plug	1

## Important Facts Concerning Your Performer 3212G

When transporting a unit with a gas engine, make sure to shut the fuel off.

The 3212G contains a clutch which engages when the unit is pumping. The pump's pressure control device engages and disengages the clutch to control pressure. To prevent unnecessary wear to the clutch it is advisable to adjust your engine speed and pressure setting so as to limit the amount of times the clutch engages and disengages. This can be accomplished as follows:

### Example:

**Operating two guns with .017 tips.** To reduce clutch wear reduce engine speed by adjusting the throttle to a low or medium setting and increase pressure only until heavy ends of spray pattern have been eliminated.

### Example:

**Operating two guns with .021 or .025 tips.** Increase engine speed to a high setting and increase pressure until heavy ends of spray pattern have been eliminated.

### Example:

**Spraying light-bodied materials at low pressure.** To reduce surging at the gun and to decrease clutch wear, reduce engine speed to idle and reduce pressure until desired spray pattern is achieved.

## Maintenance

**WARNING:** Before proceeding, follow the Pressure Relief Procedure outlined on page 5. Additionally, follow all other warnings to reduce the risk of an injection injury, injury from moving parts or electric shock. Always unplug the sprayer before servicing!

**Caution:** For detailed engine maintenance and specifications, refer to the separate engine manual supplied.

### Routine Maintenance:

**Daily:** Check and fill the gas tank. After the first 20 hours of operation: Drain the oil and refill with clean oil.

**Daily:** Check the engine oil level and fill as necessary.

**Weekly:** Remove the cover of the air filter and clean the element. Replace the element if necessary. If operating in an unusually dusty environment, check the filter daily and replace if necessary.

Replacement elements can be purchased from your local **TITAN** Dealer.

**Weekly:** Check the level of the Piston Seal Lubricant (PSL) in the displacement pump packing cup. Fill it if necessary. Keeping PSL in the cup helps lubricate the packings and piston.

After each 50 hours of operation: Change the engine oil.

**Spark Plug:** use only a (NKG) BP6ES plug. Gap the plug to 0.025 - 0.030 in. (0.7 - 0.8 mm). Be sure to use a spark plug wrench when installing and removing the plug.

## Service / Replacement of Clutch Assembly

**WARNING:** Before proceeding, follow the Pressure Relief Procedure outlined on page 5. Additionally, follow all other warnings to reduce the risk of an injection injury, injury from moving parts or electric shock. Always unplug the sprayer before servicing!

1. Remove (4) screws #30 located on page 20.
2. Slide Pump and Gear Box Assembly away from Engine.
3. Using a 1/8" allen wrench, remove 2 screws (#12) on Bushing (#11). Thread one of the screws back into the third threaded hole on the Bushing. As the Bushing loosens, you may then slide the Clutch and Spline off the Engine Shaft.
4. When re-installing, make sure that the clutch plate (#14) is set back 5/16" from the front of the spline (#10).
5. Once the clutch plate (#14) has been placed on the spline (#10), make sure that the top of the spline (#10) is even with the front of the Engine Mount (#7). This can be done by laying a straight edge across the Engine Mount and holding the spline against it while tightening the screws (#12). Make sure the Clutch surface is clean and free of oil or grease.
6. When replacing the Clutch Plate you must also replace the Spline and Clutch Rotor. This will allow even wear on the new clutch parts.

NOTE: All service work on the Engine must be done by a Honda Authorized Service Center. To locate one in your area call –

[Titan Customer Service at 1-800-526-5362.](tel:1-800-526-5362)

**See instructions and drawing outlining this procedure below.**

Pre-set dimension by using set-up tool and assembling as shown below

5/16"

Push clutch plate onto spline  
Bottoming out on set up tool

Clutch Plate  
Part No. 763-521

Clutch Spline  
Part No. 763-521

Set-Up Tool  
Part No. 763-569

Tapered Side Up

Flat Surface

5/16"

During installation of clutch plate assembly it is important to have the clutch plate properly positioned so that the proper gap between plate and mating rotor is established. Use the following method to establish this:

1. Preassemble clutch plate onto spline as shown using set-up tool.
2. Install preassembled plate & spline onto engine shaft using taper lock bushing with (2) set screws to secure in place.

NOTE: Face of spline to be flush with face of engine casting after tightening tape lock bushing. Use a straight edge for this alignment as shown.

# Gear Box

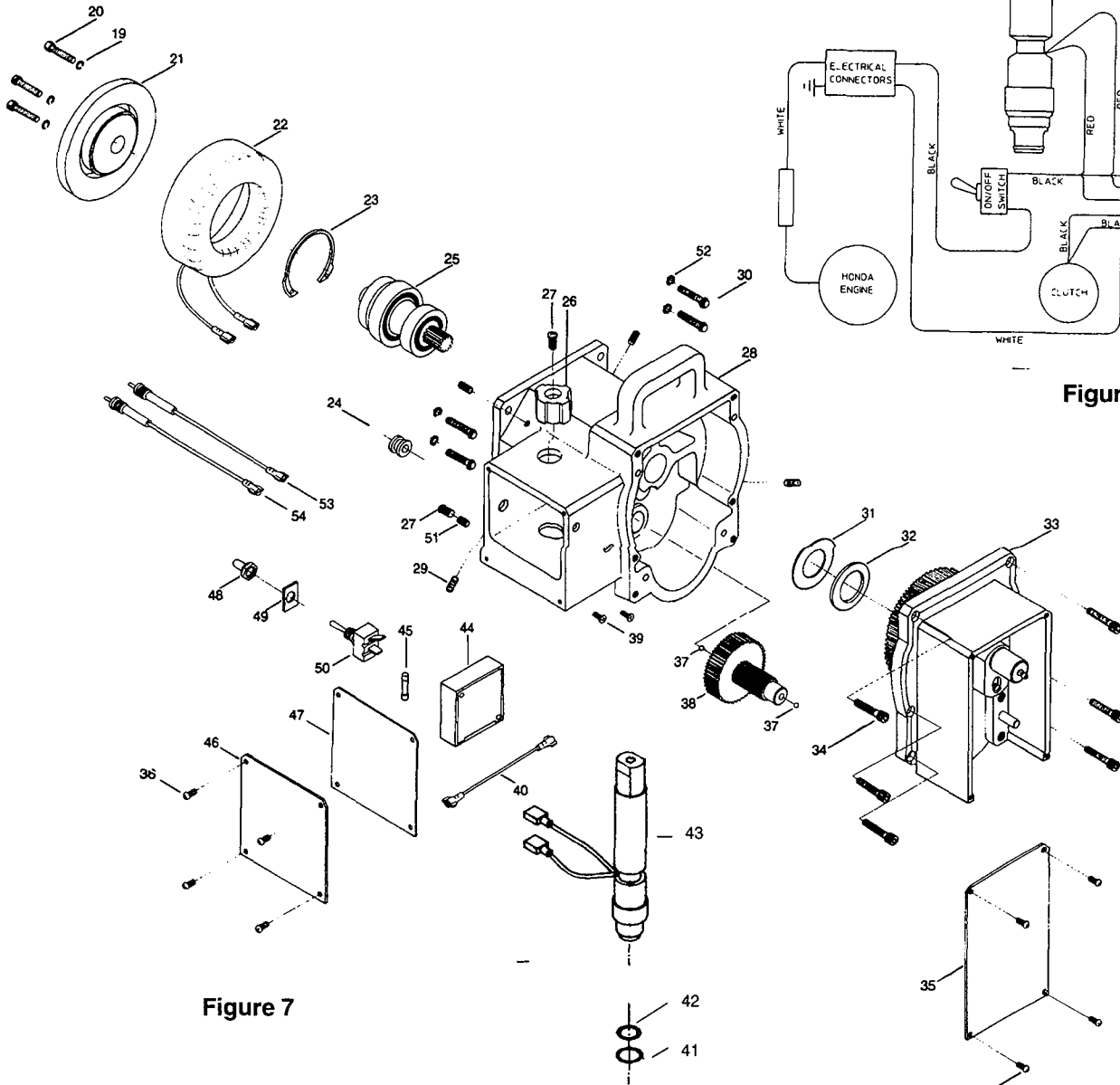

Figure 7

Figure 8

ITEM NO	PART NO	DESCRIPTION	QTY	ITEM NO	PART NO	DESCRIPTION	QTY
19	763-551	Washer	3	38	763-508	Output Pinion Gear	1
20	763-517	Screw	3	39	730-145	Screw	2
21	763-522	Clutch Rotor	1	40	700-748	Wire	1
22	763-553	Field	1	41	700-881	Gasket	1
23	763-510	Retaining Ring	1	42	700-499	O-Ring	1
24	763-561	Rubber Grommet	1	43	761-525	Pressure Switch (includes items 41, 42)	1
25	763-519	Drive Shaft & Pinion	1	44	763-557	Clutch Starter	1
26	700-771	Knob	1	45	730-146	Fuse, 5 Amp	1
27	700-884	Screw	2	46	763-515	Plate	1
28	783-031	Motor Housing	1	47	763-538	Insulator	1
29	763-525	Screw	4	48	700-645	Rubber Boot	1
30	763-526	Screw	4	49	700-775	On/Off Plate	1
31	700-680	Thrust Washer	1	50	700-646	Toggle Switch	1
32	761-221	Thrust Bearing	1	51	730-127	Screw	1
33	763-534	Crankshaft Housing	1	52	763-552	Washer	4
34	761-114	Screw	6	53	730-390	Connector	1
35	783-050	Front Cover	1	54	730-151	Connector	1
36	700-653	Screw	8				
37	761-116	Thrust Ball	2				

## Service / Replacement of The Clutch Rotor

**WARNING:** Before proceeding, follow the Pressure Relief Procedure outlined on page 5. Additionally, follow all other warnings to reduce the risk of an injection injury, injury from moving parts or electric shock. Always unplug the sprayer before servicing!

*Refer to page 20 for the following instructions:*

1. Remove four screws (#30).
2. Slide the Pump and Gear Box Assembly away from Engine.
3. Using a 3/16" allen wrench remove three screws (#20).
4. Thread one of the screws into the fourth threaded hole. This will push the Clutch Rotor away from the Drive Shaft and Pinion (#25).
5. To remove the Field Coil follow the steps above and the following:
  - A. Remove four screws (#29).
  - B. Remove cover Plate and Insulator (#46 & # 47).
  - C. Disconnect the two thin black wires located on the Clutch Starter (#44).
  - D. Carefully slide the Coil away from the Motor Housing (#28).
  - E. To reassemble proceed in reverse order.
6. To remove the Drive Shaft and Pinion (#25), follow steps 1 through 4 as above and proceed with the following:
  - A. Remove the Retaining Ring (#23).
  - B. Slide the Drive Shaft and Pinion (#25) away from the Motor Housing (#28).

## Replacement of the On/Off Switch

**WARNING:** Before proceeding, follow the Pressure Relief Procedure outlined on page 5. Additionally, follow all other warnings to reduce the risk of an injection injury, injury from moving parts or electric shock. Always unplug the sprayer before servicing!

*Refer to page 20 for the following instructions:*

1. Remove the Plate and Insulator (#46 & 47).
2. Disconnect the two black wires from the Toggle Switch (#50).
3. Remove the Rubber Boot and Plate (#48 & 49) with a wrench.
4. Remove the Toggle Switch (#50).
5. Install a new Switch and reattach the Plate and Rubber Boot. Tighten securely.
6. Reconnect the two black wires to the Toggle Switch.
7. Reinstall the Plate and Insulator with Warning Label facing out.

## Gear Repair / Service

**WARNING:** Before proceeding, follow the Pressure Relief Procedure outlined on page 5. Additionally, follow all other warnings to reduce the risk of an injection injury, injury from moving parts or electric shock. Always unplug the sprayer before servicing!

*Refer to page 20 for the following instructions:*

1. Remove the Front Cover (#35).
2. Loosen the Retaining Nut on Pipe Assembly (#300) located on page 24.
3. Remove the four screws (#303) and pull off the Slider Housing and the Fluid Section located on page 24.
4. Remove six screws (#34).
5. Remove the Crankshaft Housing (#33) by lightly tapping on each corner with a plastic mallet.
6. Remove the Output Pinion Gear (#38).
7. Examine Washers (#31) and Bearing (#32). Replace if worn.
8. Before reassembling check the following:
  - A. If installing a new gear make sure that ample grease is applied to gears and bearings.
  - B. Check that the Thrust Balls (#37) are in place.
  - C. Check that the Thrust Washer and Bearing (#31 and #32) are in place.

NOTE: Because of the amount of grease used in the Bearings where Thrust Balls are located they will generally stay in place. DO NOT ATTEMPT TO REMOVE.

## Replacement of Clutch Starter

**WARNING:** Before proceeding, follow the Pressure Relief Procedure outlined on page 5. Additionally, follow all other warnings to reduce the risk of an injection injury, injury from moving parts or electric shock. Always unplug the sprayer before servicing!

*Refer to page 20 for the following instructions:*

1. Remove the Plate and Insulator (#46 &47).
2. Disconnect the six wires that connect to the Motor Starter (#44).
3. Remove the two screws (#39).
4. Re-assemble in reverse order. Refer to the Wiring Diagram for the correct placement of the wires.

## Service / Replacement of Filter

**WARNING:** Before proceeding, follow the Pressure Relief Procedure outlined on Page 5. Additionally, follow all other warnings to reduce the risk of an injection injury, injury from moving parts or electric shock. Always unplug the sprayer before servicing!

### PUMP FILTER (CLEAN REGULARLY)

1. Unscrew Filter CAP (#11)
2. Remove Filter Element (#10). Clean or replace. Element filters from inside out. Be certain to thoroughly clean on the inside.
3. Clean or replace O-Rings and Gaskets.
4. Clean inside of filter body (#4). Remove bottom drain plug to flush.
5. Reinstall components and screw on Filter Cap completely down.

## Service/Replacement of the Pressure Relief Prime Valve

**WARNING:** Before proceeding, follow the Pressure Relief Procedure outlined on Page 5. Additionally, follow all other warnings to reduce the risk of an injection injury, injury from moving parts or electric shock. Always unplug the sprayer before servicing!

1. Remove the Dowel Pin (#13) from Bypass Valve Handle (#12)
2. Remove Handle (#12) and Bypass Cam (#14)
3. Using a wrench, loosen Bypass Housing (#19) and unscrew.
4. Unscrew Bypass Retainer (#15) and remove Valve Stem (#17).
5. Inspect ball on end of Stem (#17) and O-Ring (#18). Clean or replace if worn. Check, clean and replace if worn all other components.
6. Reassemble components and screw assembly into manifold (#2). Tighten securely with wrench.
7. Install Bypass Cam (#14) over Retainer (#15) lubricate with grease. Line up Dowel Pin of Cam Base with hole on Manifold.
8. Line up hole of Stem (#17) with hole of Handle (#12) and tap in Dowel Pin (#13)

**IMPORTANT:** If Handle (#12) rotates 360° check Dowel Pin installation.

## Manifold/Filter Assembly

ITEM NO	PART NO	DESCRIPTION	QTY
1	783-036	Hose (High Pressure)	1
2	781-002	Manifold	1
3	781-005	Fitting	1
4	920-927	Filter Body	1
5	227-027	Pipe Plug	2
6	812-003	Fitting	1
7	227-033	Pipe Plug	1
8	920-070	Gasket: PTFE Thin	1
9	920-006	Gasket: PTFE Thick	1
10	920-004	Filter Element, 50 Mesh	1
10a	920-001	Filter Element, 5 Mesh	opt.
10b	920-005	Filter Element, 100 Mesh	opt.
11	920-917	Filter Cap	1
12	700-697	Bypass Valve Handle	1
13	700-759	Dowel Pin	1
14	700-252	Bypass Valve Cam Base	1
15	700-248	Bypass Valve Retainer	1
16	700-244	Spring	1
17	700-250	Bypass Valve Stem	1
18	700-721	O-Ring	1
18a	700-897	O-Ring PTFE	opt.
19	700-246	Housing (incl. #20 & #21)	1
20	222-012	O-Ring	1
21	221-012	O-Ring	1
22	700-537	Gasket	1
23	700-258	Bypass Valve (complete)	1
24	783-041	Screw	2
25	761-256	Lock Washer	2
26	702-239	Bypass Hose	1
27	730-334	Clip (To Down Tube)	1

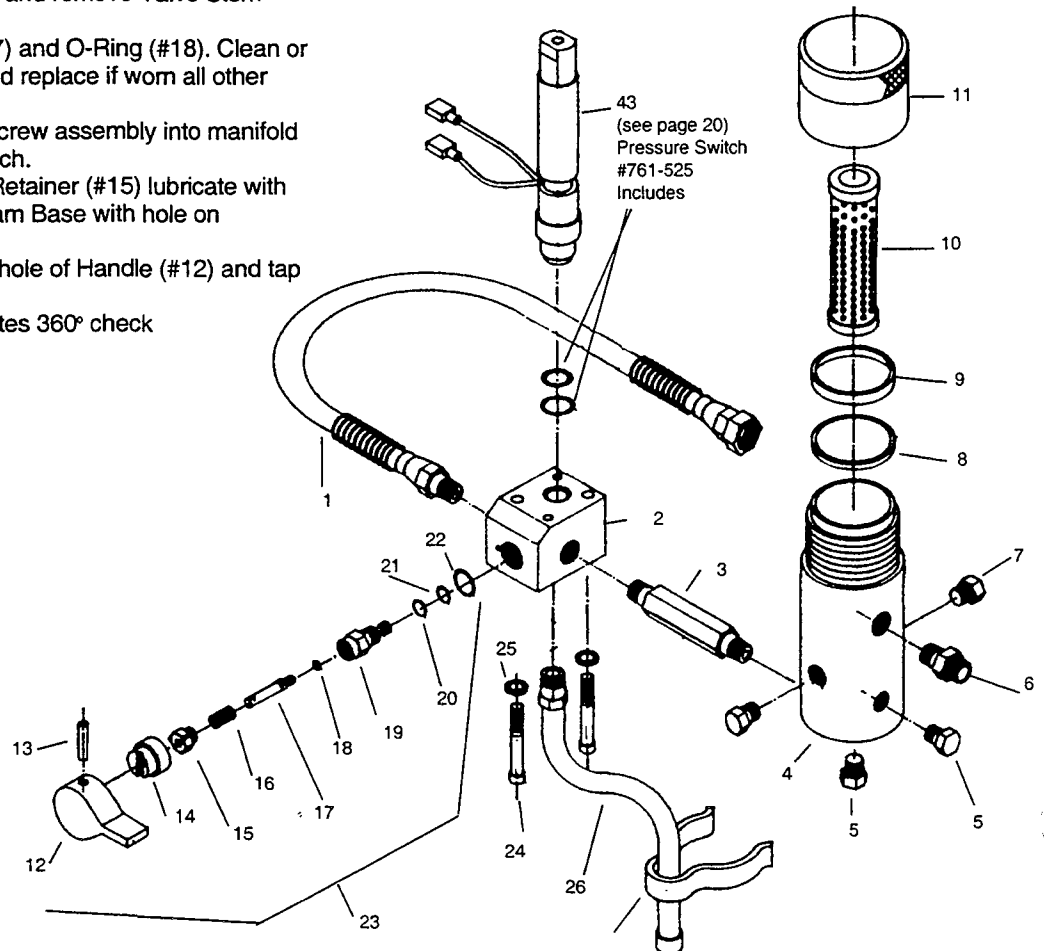

# Pressure Switch Replacement

**WARNING:** Before proceeding, follow the Pressure Relief Procedure outlined on page 5. Additionally, follow all other warnings to reduce the risk of an injection injury, injury from moving parts or electric shock. Always unplug the sprayer before servicing!

1. Remove the two screws (#24) from bottom of Manifold p. 22
2. Unscrew nut of hose (#300) from the Connector (#310) p. 24
3. Remove the Filter/Manifold Assembly. (p 22)

**Refer to Page 20 for the following instructions:**

4. Remove the Screw (#35) and remove the Knob (#68).
5. Remove the Cover Plate and Insulator (#37 & 38).
6. Disconnect the red wires connecting to the Clutch Starter (#42).
7. Remove the screw (#35) located in the back of the Electrical Box. Insert a 1/8" allen wrench in the hold and back-off the set screw (#44) until the Pressure Switch (#43) is able to slide down through. Feed the electrical wires down at the same time.
8. Insert a new Switch Assembly (#48) into the housing (#65) while carefully guiding the wire into the Switch Box. Using a needle nose pliers reconnect the wire to the Clutch Starter.
9. Making sure that the Switch Assembly is full inserted, tighten the Set Screw (#44) with a 1/8" allen wrench until the Switch Assembly is secure. Reattach the Knob (#68).
10. Make sure that the Gasket (#50) is in place. Then install the Manifold Assembly p. 22. Secure with two screws and reattach the Retaining Nut on the Hose (#300) to the Connector (#310) p. 24.
11. Install the Cover Plate and Insulator (#37 & #38) p. 20.
12. The Pressure Switch is factory calibrated; no adjustment is required.

# Gun Filter

**WARNING:** Follow all safety precautions as described in high pressure warning section before proceeding. If your spray gun leaks or spits at the tip when you release the trigger, the needle or seat is dirty, worn or damaged and must be cleaned or replaced.

**Replacement or Removal of Filter:**

1. First pull down on trigger safety guard and swing away from handle.
2. Unscrew handle from spray head.
3. Unscrew left hand threaded\* filter from spray head. (\*NOTE: Left handed thread requires turning the filter clockwise to remove.)
4. Screw new or cleaned (†) filter into the head. To reinstall left hand thread turn counterclockwise.
5. Reattach handle to head and secure safety trigger guard. (NOTE: If filter breaks off in the head use a small wood screw to remove.)

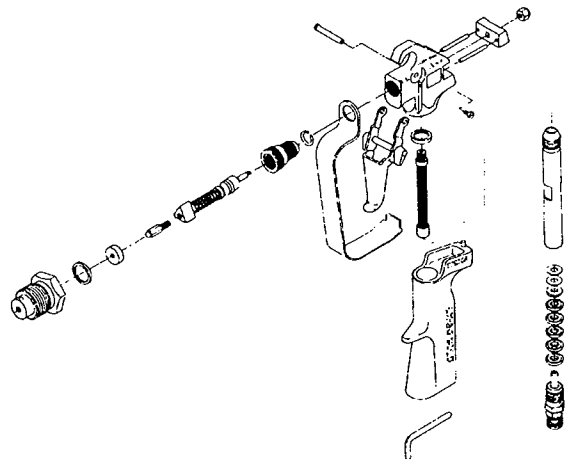
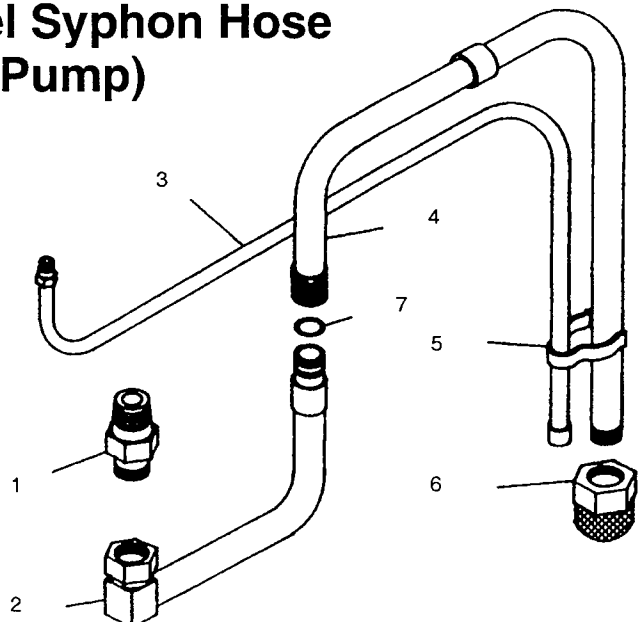

**Figure 9** -- For more detail, part number information and assembly drawings at larger scale, please see the LX 80 Gold Professional Airless Gun Owner's Manual (#313-687).

# 5 Gal (55 Gal) Swivel Syphon Hose (Low Rider Pump)

781-060 SYPHON HOSE (COMPLETE) INCLUDES ITEMS 1-6

ITEM NO	PART NO	DESCRIPTION	QTY
1	710-081	Adapter	1
2	757-068	Syphon Tube	1
*3	783-043	Bypass Hose 5 Gal.	1
*4	710-203	Syphon Hose 5 Gal.	1
5	730-334	Clip	1
6	710-046	Inlet Screen	1
7	710-196	O-Ring	1
8	710-219	Bypass Hose 55 Gal.	Opt.
9	783-043	Syphon Hose 55 Gal.	Opt.



# Fluid Section

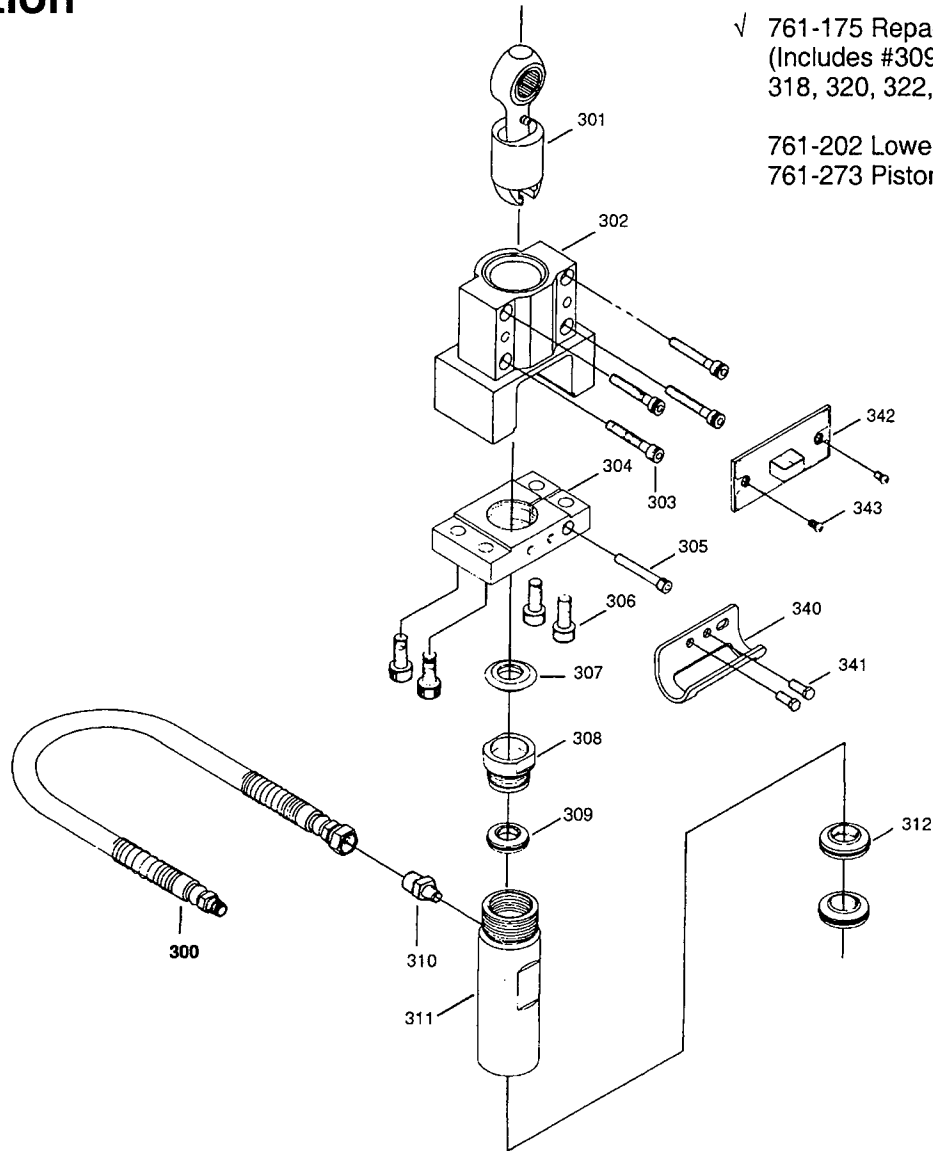

√ 761-175 Repacking Kit  
(Includes #309, 312, 314, 316, 318, 320, 322, 324, 326)

761-202 Lower Packing Tool  
761-273 Piston Guide Tool

Figure 10

ITEM NO	PART NO	DESCRIPTION	QTY	ITEM NO	PART NO	DESCRIPTION	QTY
300	783-036	Hose Assembly	1	320	761-103	√ O-Ring	1
301	761-062	Crank Slide & Connecting Rod	1	321	761-064	Lower Housing	1
302	783-236	Slider Housing	1	322	761-076	√ Lower Poly Seal	1
303	761-115	Screw	4	323	761-075	Lower Cage	1
304	761-034	Upper Mount	1	324	*761-145	√ Lower Ball	1
305	761-149	Screw	1	325	761-080	Lower Seat	1
306	761-148	Screw	4	326	761-058	√ O-Ring	1
307	761-162	Splash Guard	1	327	761-123	Foot Valve Housing	1
308	761-077	Upper Guide	1	328	761-153	Down Tube	1
309	761-072	√ Upper Seal	1	329	710-046	Inlet Screen	1
310	490-006	Connector	1	340	761-033	Pail Hook	1
311	761-118	Upper Housing	1	341	710-033	Screw	2
312	761-138	√ Lower Seal	2	342	761-171	Safety Plate	1
313	761-117	Piston Rod	1	343	730-260	Screw	2
314	761-111	√ Upper Poly Seal	1				
315	761-078	Upper Cage	1				
316	*761-144	√ Upper Ball	1				
317	761-079	Upper Seat	1				
318	761-057	√ O-Ring	1				
319	761-073	Retainer	1				

\*Recommended Tool Box Parts

762-204 Fluid Section Complete  
(Does not include #300, 301, 302, 303, 306, 328-343)



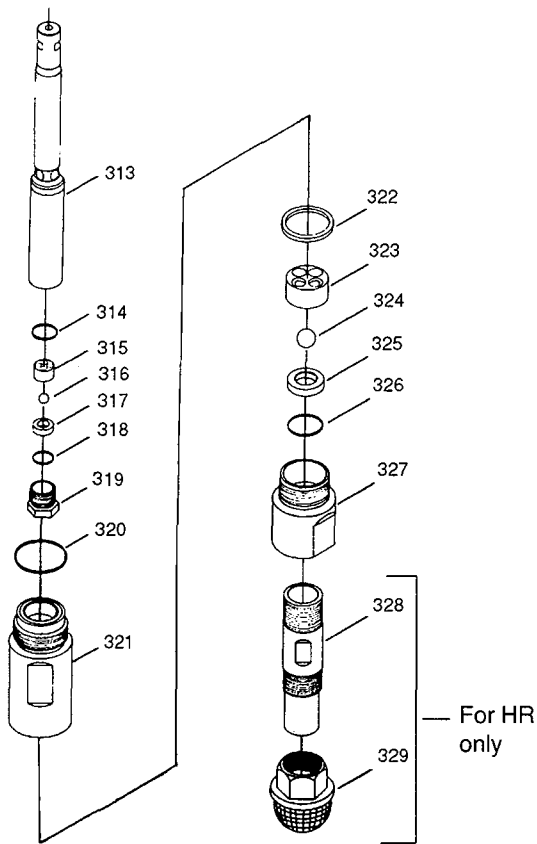

Figure 11

For LR see pg 23

## Pump Section Repair and Packing Replacement

**WARNING:** Before proceeding, follow the Pressure Relief Procedure outlined on Page 5. Additionally, follow all other warnings to reduce the risk of an injection injury, injury from moving parts or electric shock. Always unplug the sprayer before servicing!

1. Stop Sprayer at the bottom of its stroke and remove Safety Plate (#342).
2. Using a 3/8" allen wrench remove four screws (#306).
3. Using a 3/4" wrench loosen the retaining nut on the Pipe Assembly (#300) from Item (#310).
4. Place a screwdriver between Item (#304) and (#302) and lightly pry downward.
5. Pull Fluid Section Forward.
6. Place Foot Valve Housing (#327) in a vise and use a wrench on the Lower Housing (#321) to unthread.
7. Remove the Lower Seal (#322) from inside the Lower Housing (#321).
8. Remove the Lower Cage (#323) from the Foot Valve Housing (#327).
9. Remove Lower Ball (#324) and examine.
10. Remove Lower Seat (#325). If damaged use other side or replace.
11. Remove Seal (#326).
12. Place the Lower Housing in a vise and use a wrench on the Upper Housing (#311) to unthread.
13. Remove Seal (#320) from outside of the Lower Housing (#321).

## Seat Service and Repair

**WARNING:** Before proceeding, follow the Pressure Relief Procedure outlined on Page 5. Additionally, follow all other warnings to reduce the risk of an injection injury, injury from moving parts or electric shock. Always unplug the sprayer before servicing!

The design of Titan's Epic Fluid Section allows access to the inlet and outlet balls and seat without completely disassembling the Fluid Section. It is possible that the Balls may not seat properly because of debris stuck in the inlet or outlet seat. Follow the instruction below for access to those areas.

1. Place a wrench on the Foot Valve (#327) and unthread.
2. Clean out all debris. Examine Ball and Seat. If damaged replace. Continue if necessary or reinstall.
3. Place a wrench on the Lower Pump Housing (#321) and unthread.
4. Place a wrench on the Retainer (#319) and unthread.
5. Clean out all debris. Examine Ball and Seat. If damaged replace.
6. Reassemble and test unit. Should unit not perform properly consult the Troubleshooting Guides on pages 13 & 14 of this manual or continue with the Repair and Packing Replacement instructions below.

14. Place the Upper Housing (#311) in a vise and use a wrench on the Upper Guide (#308) to unthread.
15. Using a Plastic Mallet Tap the Piston Rod (#313) out of the Bottom of the Upper Housing (#311).
16. Place the Piston Rod (#313) in the slots of the Slider (#301) which is still mounted on the unit. This will hold the Piston in place when removing the Retainer (#319). NOTE: Never use wrench on the Piston.
17. Remove Upper Seal (#314) from inside of Piston Rod (#313).
18. Remove Upper Cage (#315) from the Retainer (#319).
19. Remove the Upper Ball (#316) and examine.
20. Remove Upper Seat (#317). If damaged use the other side or replace.
21. Remove Seal (#318) from the Retainer (#319).
22. Remove the Upper Packing (#309) from the Upper Housing (#311).
23. Remove both Lower Packing (#312) from inside the Upper Housing (#311). **WARNING: Always insert Packings with the raised side facing into the Upper Housing.**
24. Assemble in reverse order.
- Be sure to use all of the replacement parts supplied in the Repacking Kit #761-175.**
25. Align Flats on Piston so that it is perpendicular to the Upper Mount (#304).
26. Reattach the four screws (#306) to the Pump Mount (#304).
27. Reattach Retaining Nut on Pipe Assembly (#300) to Connector (#310).

NOTE: Make sure to fill the Upper Guide (#308) one-third (1/3) full with Piston Seal Lubricant.

MODEL #	SERIAL #	DATE PURCHASED	COMPANY NAME
---------	----------	----------------	--------------

## Equipment Job History

In order to help you track the superior performance of your Titan Sprayer we recommend you keep this log for your records. We feel you may find it useful for gauging on-site performance, invoicing or overtime and your estimator's reference.

Job Name	Foreman's Name	Type of Coating	Tips Used		Date Completed
Date Begun	Site	Gallons Sprayed	Sizes	Quantity	
Job Name	Foreman's Name	Type of Coating	Tips Used		Date Completed
Date Begun	Site	Gallons Sprayed	Sizes	Quantity	
Job Name	Foreman's Name	Type of Coating	Tips Used		Date Completed
Date Begun	Site	Gallons Sprayed	Sizes	Quantity	
Job Name	Foreman's Name	Type of Coating	Tips Used		Date Completed
Date Begun	Site	Gallons Sprayed	Sizes	Quantity	
Job Name	Foreman's Name	Type of Coating	Tips Used		Date Completed
Date Begun	Site	Gallons Sprayed	Sizes	Quantity	
Job Name	Foreman's Name	Type of Coating	Tips Used		Date Completed
Date Begun	Site	Gallons Sprayed	Sizes	Quantity	
Job Name	Foreman's Name	Type of Coating	Tips Used		Date Completed
Date Begun	Site	Gallons Sprayed	Sizes	Quantity	
Job Name	Foreman's Name	Type of Coating	Tips Used		Date Completed
Date Begun	Site	Gallons Sprayed	Sizes	Quantity	
Job Name	Foreman's Name	Type of Coating	Tips Used		Date Completed
Date Begun	Site	Gallons Sprayed	Sizes	Quantity	
Job Name	Foreman's Name	Type of Coating	Tips Used		Date Completed
Date Begun	Site	Gallons Sprayed	Sizes	Quantity	
Job Name	Foreman's Name	Type of Coating	Tips Used		Date Completed
Date Begun	Site	Gallons Sprayed	Sizes	Quantity	
Job Name	Foreman's Name	Type of Coating	Tips Used		Date Completed
Date Begun	Site	Gallons Sprayed	Sizes	Quantity	
Job Name	Foreman's Name	Type of Coating	Tips Used		Date Completed
Date Begun	Site	Gallons Sprayed	Sizes	Quantity	

# NOTES

PUMP	OPERATING PRESSURE	MAXIMUM TIP SIZE	WEIGHT	AMP DRAW MAX psi	MAXIMUM GPM OUTPUT	MAXIMUM HOSE LENGTH**	POWER SOURCE	PRODUCT NUMBER PUMP ONLY	PRODUCT NO. COMPLETE (with 50' Hose & LX-80 Gun)
<b>DP-30</b>	0-3000 psi	.017 w/1 gun	37 lbs	8	.33	100 ft	1/2 HP totally enclosed AC motor	703-095	703-100
<b>440HP</b>	0-3200 psi	.021 w/1 gun	27 lbs	9	.44	100 ft	3/4 hp AC motor	700-155	700-135
<b>447HPX</b>	0-3200 psi	.023 w/1 gun	33 lbs	11	.55	150 ft	.85 HP totally enclosed AC motor	765-100	765-110
<b>660HPX</b>	0-3200 psi	.025 w/1 gun	56 lbs	15	.72	200 ft	1.0 HP totally enclosed AC motor	702-405	702-410
<b>690HPG</b>	0-3200 psi	.025 w/1 gun	78 lbs	.	.80	250 ft	4.0 HP Honda engine	755-095	755-100
<b>1100HPX</b>	0-3200 psi	.031 w/1 gun .021 w/2 guns	90 lbs	15	1.0	300 ft	1.75 HP totally enclosed AC motor	781-101 (120v) HR 781-105-CE (230v) HR 781-103 (120v) LR 781-107-CE (230v) LR	781-100 (120v) HR 781-104-CE (230v) HR 781-102 (120v) LR 781-106-CE (230v) LR
<b>1200HPG</b>	0-3200 psi	.035 w/1 gun .025 w/2 guns .019 w/3 guns	125 lbs		1.35	300 ft	5.5 HP Honda engine	783-101 HR 783-111 LR	783-100 HR 783-110 LR

\*\* Hose length depends on material being sprayed, hose diameter and tip size.  
 \*\*\* DP-30 supplied with 25' of hose and a Profit Gun.

## TITAN WARRANTY FOR THE 1200HPG

Titan Tool, Inc., ("Titan") warrants that at the time of delivery to the original purchaser for use ("End User"), the equipment covered by this warranty is free from defects in material and workmanship. Titan's obligation under this warranty is limited to replacing or repairing without charge those parts which, to Titan's reasonable satisfaction, are shown to be defective within twelve (12) months with the exception of defects in the parts of the drive train/gear box or pressure control assembly which will be repaired or replaced for twenty four months after sale to the End User. This warranty applies only when the unit is installed and operated in accordance with the recommendations and instructions of Titan.

This warranty does not apply in the case of damage or wear caused by abrasion, corrosion or misuse, negligence, accident, faulty installation, substitution of non-Titan component parts, or tampering with the unit in a manner to impair normal operation.

Defective parts are to be returned to an authorized Titan sales/service outlet. All transportation charges, including return to the factory, if necessary, are to be borne and prepaid by the End User. Repaired or replaced equipment will be returned to the End User transportation prepaid.

THERE IS NO OTHER EXPRESS WARRANTY. TITAN HEREBY DISCLAIMS ANY AND ALL IMPLIED WARRANTIES INCLUDING, BUT NOT LIMITED TO, THOSE OF MERCHANTABILITY AND FITNESS FOR A PARTICULAR PURPOSE, TO THE EXTENT PERMITTED BY LAW. THE DURATION OF ANY IMPLIED WARRANTIES WHICH CANNOT BE DISCLAIMED IS LIMITED TO THE TIME PERIOD SPECIFIED IN THE EXPRESS WARRANTY. IN NO CASE SHALL TITAN LIABILITY EXCEED THE AMOUNT OF THE PURCHASE PRICE. LIABILITY FOR CONSEQUENTIAL, INCIDENTAL OR SPECIAL DAMAGES UNDER ANY AND ALL WARRANTIES IS EXCLUDED TO THE EXTENT PERMITTED BY LAW.

TITAN MAKES NO WARRANTY AND DISCLAIMS ALL IMPLIED WARRANTIES OF MERCHANTABILITY AND FITNESS FOR A PARTICULAR PURPOSE WITH RESPECT TO ACCESSORIES, EQUIPMENT, MATERIALS OR COMPONENTS SOLD BUT NOT MANUFACTURED BY TITAN. THOSE ITEMS SOLD, BUT NOT MANUFACTURED BY TITAN (SUCH AS GAS ENGINES, SWITCHES, HOSES, ETC.) ARE SUBJECT TO THE WARRANTY, IF ANY, OF THEIR MANUFACTURER. TITAN WILL PROVIDE THE PURCHASER WITH REASONABLE ASSISTANCE IN MAKING ANY CLAIM FOR BREACH OF THESE WARRANTIES.

 	<b>National Sales &amp; Service</b> 1-800-526-5362 Fax 1-800-528-4826	<b>Canadian Branch</b> 1-800-565-8665 Fax 1-905-856-8496	<b>International</b> 1-201-405-7520 Fax 1-201-405-7449
	©1997 Titan Tool Inc. 313 -1233 Printed in the U.S.A. 0799B	556 Commerce Street Franklin Lakes, NJ 07417	200 Towers Road, Unit 7B Woodbridge, L4L 5Z8

Titan and Speedflo are registered trademarks and Epic is a trademark of Titan Tool Inc.