



Owner's Manual

For professional use only

**Do not use this equipment
before reading this manual!**

PowerTwin 12000XLT



Model Number:

Gas Bare	459-305
DC Electric Bare	459-310
Gas Complete	459-315
Gas/Electric Complete	459-320

NOTE: This manual contains important warnings and instructions. Please read and retain for reference.

Table of Contents

Safety Precautions	2
Grounding Instructions	3
Gasoline Engine Safety	4
Specifications	4
Introduction	5
Operation	5
Fueling	5
Setup	6
Preparing to Paint	7
Painting	8
Pressure Relief Procedure	9
Cleanup	9
Cleaning a Clogged Tip	10
Maintenance	10
Daily Maintenance	10
Maintaining the Filter Assembly	10
Maintaining the Hydraulic System	11
Maintaining the Fluid Section	11
Basic Engine Maintenance (gas engine)	11
Replacing the Motor Brushes (electric motor)	12
Troubleshooting	13
Airless Gun	13
Fluid Section	13
Hydraulic Motor	14
Spray Patterns	15
Parts Lists and Service Instructions	20
Main Assembly	20
Bleed Hose Assembly with Valve	20
Cart Assembly	21
Belt Guard Assembly	21
DC— Electric Convertokit	22
Gas Convertokit	23
Siphon Hose Assembly	23
Bleed Valve Assembly	24
Filter Assembly	24
Hydraulic System	25
Hydraulic Motor	26
Fluid Section	28
Gun Manifold Assemblies (optional)	30
SAE O-Ring Fitting Installation	31
Accessories and Service Kits	31
Airless Tip Selection	31
Warranty	32

Safety Precautions

This manual contains information that must be read and understood before using the equipment. When you come to an area that has one of the following symbols, pay particular attention and make certain to heed the safeguard.



This symbol indicates a potential hazard that may cause serious injury or loss of life. Important safety information will follow.



This symbol indicates a potential hazard to you or to the equipment. Important information that tells how to prevent damage to the equipment or how to avoid causes of minor injuries will follow.

NOTE: Notes give important information that should be given special attention.



HAZARD: Injection injury - A high pressure stream produced by this equipment can pierce the skin and underlying tissues, leading to serious injury and possible amputation. See a physician immediately.

DO NOT TREAT AN INJECTION INJURY AS A SIMPLE CUT! Injection can lead to amputation. See a physician immediately.

The maximum operating range of the gun is 3300 PSI / 22.8 MPa fluid pressure.

PREVENTION:

- NEVER aim the gun at any part of the body.
- NEVER allow any part of the body to touch the fluid stream. DO NOT allow body to touch a leak in the fluid hose.
- NEVER put your hand in front of the gun. Gloves will not provide protection against an injection injury.
- ALWAYS lock the gun trigger, shut the pump off, and release all pressure before servicing, cleaning the tip or guard, changing tip, or leaving unattended. Pressure will not be released by turning off the motor. The PRIME/SPRAY valve or pressure bleed valve must be turned to their appropriate positions to relieve system pressure. Refer to the PRESSURE RELIEF PROCEDURE described in this manual.
- ALWAYS keep the tip guard in place while spraying. The tip guard provides some protection but is mainly a warning device.
- ALWAYS remove the spray tip before flushing or cleaning the system.
- The paint hose can develop leaks from wear, kinking and abuse. A leak can inject material into the skin. Inspect the hose before each use.
- NEVER use a spray gun without a trigger lock and trigger guard in place and in good working order.
- All accessories must be rated at or above the maximum operating pressure range of the airless sprayer. This includes spray tips, guns, extensions, and hose.

NOTE TO PHYSICIAN:

Injection into the skin is a traumatic injury. It is important to treat the injury as soon as possible. DO NOT delay treatment to research toxicity. Toxicity is a concern with some coatings injected directly into the blood stream. Consultation with a plastic surgeon or reconstructive hand surgeon may be advisable.

HAZARD: EXPLOSION OR FIRE - Solvent and paint fumes can explode or ignite. Severe injury and/or property damage can occur.

PREVENTION:

- Provide extensive exhaust and fresh air introduction to keep the air within the spray area free from accumulation of flammable vapors.
- Avoid all ignition sources such as static electric sparks, open flames, pilot lights, and hot objects. Connecting or disconnecting power cords or working light switches can make sparks.
- Do not smoke in spray area.
- Fire extinguisher must be present and in good working order.
- Place paint pump in a well ventilated area. Flammable vapors are often heavier than air. Floor area must be extremely well ventilated. The paint pump contains arcing parts that emit spark and can ignite vapors.
- The equipment and objects in and around the spray area must be properly grounded to prevent static sparks.
- Use only conductive or grounded high pressure fluid hose. Gun must be grounded through hose connections.

- Power cord must be connected to a grounded circuit (electric models only).
- Always flush unit into a separate metal container, at low pump pressure, with spray tip removed. Hold gun firmly against side of container to ground container and prevent static sparks.
- Follow the material and solvent manufacturer's warnings and instructions.
- Use extreme caution when using materials with a flashpoint below 70° F (21° C). Flashpoint is the temperature that a fluid can produce enough vapors to ignite.
- Plastic can cause static sparks. Never hang plastic to enclose a spray area. Do not use plastic drop cloths when spraying flammable materials.
- Use lowest possible pressure to flush equipment.

GAS ENGINE (WHERE APPLICABLE)

Always place pump outside of structure in fresh air. Keep all solvents away from the engine exhaust. Never fill fuel tank with a running or hot engine. Hot surface can ignite spilled fuel. Always attach ground wire from pump unit to a grounded object, such as a metal water pipe. Refer to engine owner's manual for complete safety information.

HAZARD: EXPLOSION HAZARD DUE TO INCOMPATIBLE MATERIALS - Will cause severe injury or property damage.

PREVENTION:

- Do not use materials containing bleach or chlorine.
- Do not use halogenated hydrocarbon solvents such as mildewcide, methylene chloride and 1,1,1 - trichloroethane. They are not compatible with aluminum.
- Contact your coating supplier about the compatibility of material with aluminum.

HAZARD: HAZARDOUS VAPORS - Paints, solvents, insecticides, and other materials can be harmful if inhaled or come in contact with the body. Vapors can cause severe nausea, fainting, or poisoning.

PREVENTION:

- Use a respirator or mask if vapors can be inhaled. Read all instructions supplied with the mask to be sure it will provide the necessary protection.
- Wear protective eyewear.
- Wear protective clothing as required by coating manufacturer.

HAZARD: GENERAL - This product can cause severe injury or property damage.

PREVENTION:

- Read all instructions and safety precautions before operating equipment.
- Always disconnect the motor from the power supply before working on the equipment (electric models only).
- Follow all appropriate local, state, and national codes governing ventilation, fire prevention, and operation.
- The United States Government Safety Standards have been adopted under the Occupational Safety and Health Act (OSHA). These standards, particularly part 1910 of the General Standards and part 1926 of the Construction Standards should be consulted.
- Use only manufacturer authorized parts. User assumes all risks and liabilities when using parts that do not meet the minimum specifications and safety devices of the pump manufacturer.
- Before each use, check all hoses for cuts, leaks, abrasion or bulging of cover. Check for damage or movement of couplings. Immediately replace the hose if any of these conditions exist. Never repair a paint hose. Replace it with another grounded high-pressure hose.
- Do not spray outdoors on windy days.
- Wear clothing to keep paint off skin and hair.

Grounding Instructions

Electric models must be grounded. In the event of an electrical short circuit, grounding reduces the risk of electric shock by providing an escape wire for the electric current. This product is equipped with a cord having a grounding wire with an appropriate grounding plug. The plug must be plugged into an outlet that is properly installed and grounded in accordance with all local codes and ordinances.

DANGER — Improper installation of the grounding plug can result in a risk of electric shock. If repair or replacement of the cord or plug is necessary, do not connect the green grounding wire to either flat blade terminal. The wire with insulation having a green outer surface with or without yellow stripes is the grounding wire and must be connected to the grounding pin.

Check with a qualified electrician or serviceman if the grounding instructions are not completely understood, or if you are in doubt as to whether the product is properly grounded. Do not modify the plug provided. If the plug will not fit the outlet, have the proper outlet installed by a qualified electrician.

This product is rated more than 15 amperes and is for use on a circuit having a nominal rating of 120 volts, or the product is for use on a circuit having a nominal rating more than 120 volts, and is factory-equipped with a specific electric cord and plug to permit connection to a proper electric circuit. Make sure that the product is connected to an outlet having the same configuration as the plug. No adapter should be used with this product. If the product must be reconnected for use on a different type of electric circuit, the reconnection should be made by qualified service personnel.



Use only a 3-wire extension cord that has a 3-blade grounding plug and a 3-slot receptacle that will accept the plug on the product. Make sure your extension cord is in good condition. When using an extension cord, be sure to use one heavy enough to carry the current your product will draw. An undersized cord will cause a drop in line voltage resulting in loss of power and overheating. For lengths less than 50 feet, No. 12 AWG extension cords should be used. If an extension cord is to be used outdoors, it must be marked with the suffix W-A after the cord type designation. For example, a designation of SJTW-A would indicate that the cord would be appropriate for outdoor use.

Gasoline Engine Safety



The engine exhaust from this unit contains chemicals known to the State of California to cause cancer, birth defects, or other reproductive harm.

1. Honda engines are designed to give safe and dependable service if operated according to instructions. Read and understand the Honda Owner's Manual before operating the engine. Failure to do so could result in personal injury or equipment damage.
2. To prevent fire hazards and to provide adequate ventilation, keep the engine at least 1 meter (3 feet) away from buildings and other equipment during operation. Do not place flammable objects close to the engine.
3. Children and pets must be kept away from the area of operation due to a possibility of burns from hot engine components or injury from any equipment the engine may be used to operate.
4. Know how to stop the engine quickly, and understand the operation of all controls. Never permit anyone to operate the engine without proper instructions.
5. Gasoline is extremely flammable and is explosive under certain conditions.
6. Refuel in a well-ventilated area with the engine stopped. Do not smoke or allow flames or sparks in the refueling area or where gasoline is stored.
7. Do not overfill the fuel tank. After refueling, make sure the tank cap is closed properly and securely.
8. Be careful not to spill fuel when refueling. Fuel vapor or spilled fuel may ignite. If any fuel is spilled, make sure the area is dry before starting the engine.
9. Never run the engine in an enclosed or confined area. Exhaust contains poisonous carbon monoxide gas; exposure may cause loss of consciousness and may lead to death.
10. The muffler becomes very hot during operation and remains hot for a while after stopping the engine. Be careful not to touch the muffler while it is hot. To avoid severe burns or fire hazards, let the engine cool before transporting it or storing it indoors.
11. Never ship/transport unit with gasoline in the tank.



DO NOT use this equipment to spray water or acid.



Do not lift by cart handle when loading or unloading.

Warning Labels

Your sprayer has the English language warning labels. If you require these labels in French, German, or Spanish, or require additional English labels, order directly from Speedflo free of charge.

Part #	Language
313-771 313-784 313-1837	English
313-1306 313-1307	Spanish
313-785 313-786	French
313-787 313-788	German

Specifications

Gas Unit

- Gallons per minute (GPM)3.15 (11.9 LPM)
- Cycle rate per gallon.....38 (10.5 cycles/liter)
- Maximum tip sizes1 gun = .058"
2 guns = .040"
3 guns = .034"
4 guns = .030"
5 guns = .026"
6 guns = .024"
- Maximum pressure3300 PSI (22.8 MPa)
- PowerHonda 9 HP, 4-stroke, single cylinder, overhead valve engine w/oil alert
- Fuel capacity1.6 US gallons (approx. 2.5 hours run time)
- Halogenated solvent compatible.....Yes
- Weight183 lbs. (83 kg.)
- Inlet paint filter10 mesh "Rock Catcher"
- Outlet paint filter.....50 mesh, 18 in.²
- Pump inlet1" NPT(F)
- Pump outlet.....1/2" NPT(F) to paint filter
- Paint filter hose connections.....1/4" NPS(M)
3/8" NPT(F) (plugged)
3/8" NPS(M)
- Dimensions46" L (116.8 cm) x
27" W (68.6 cm) x
34" H (86.6 cm)

Fluid section wetted parts:

Electroless nickel plated ductile iron, electroless nickel plated carbon steel, stainless steel, tungsten carbide, UVØØ, thiokol impregnated leather, ultra high molecular weight polyethylene.

Electric Unit

- Gallons per minute (GPM)1.25 (4.7 LPM)
- Cycle rate per gallon.....40 (10.5 cycles/liter)
- Maximum tip sizes1 gun = .036"
2 guns = .026"
3 guns = .019"
- Maximum pressure3300 psi (22.8 MPa)
- Power2 HP DC Motor, 115V 15.5A, overload protected
- Halogenated solvent compatible.....Yes
- Weight188 lbs. (85.3 kg.)
- Inlet paint filter10 mesh "Rock Catcher"
- Outlet paint filter.....50 mesh, 18 in.²
- Pump inlet1" NPT(F)
- Pump outlet.....1/2" NPT(F) to paint filter
- Paint filter hose connections.....1/4" NPS(M)
3/8" NPT(F) (plugged)
3/8" NPS(M)
- Dimensions46" L (116.8 cm) x
27" W (68.6 cm) x
34" H (86.6 cm)

Fluid section wetted parts:

Electroless nickel plated ductile iron, electroless nickel plated carbon steel, stainless steel, tungsten carbide, UVØØ, thiokol impregnated leather, ultra high molecular weight polyethylene.



Introduction

Congratulations on having selected the finest airless sprayer available in the world. Speeflo piston pumps are tireless workhorses — so tough they are virtually indestructible, even under the most severe service. Speeflo designs and builds equipment with superior quality and reliability. Equipment that will last for years with minimal maintenance and downtime. This equipment will make you money year after year. We thank you for your purchase and welcome you to our large and growing family of Speeflo users.

The unique ability of this PowrTwin to operate with either gas or electric power provides you with the flexibility to work indoors or outside where no electricity is available.

Hydraulic drive makes possible the longest stroke and slowest cycling pumps in the industry, which translates into low maintenance and longer life. Electric units operate quietly with no motor starting and stopping.

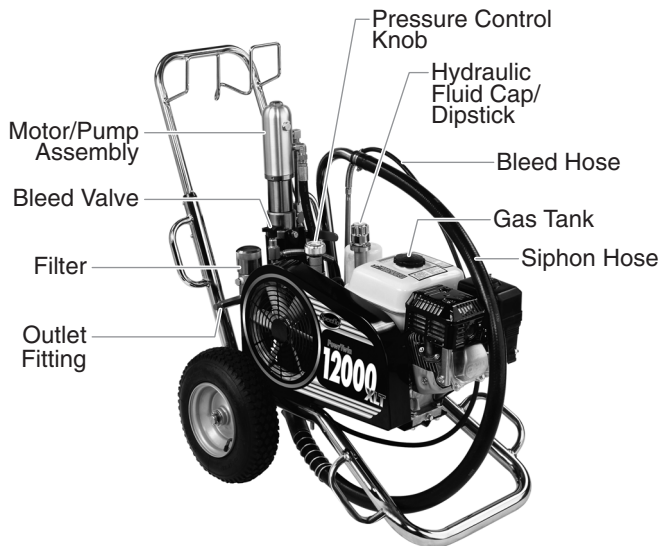

This PowrTwin is equipped with Speeflo's exclusive fluid pump. This technology will give you significantly longer rod, cylinder, and packing life than any other sprayer built in the world. This double ball piston pump employs a dependable and durable time-tested design. All pumps use thick, stainless steel rod and cylinder parts. This proprietary heat-treating process is much more abrasion resistant than any other material used by other paint pump manufacturers. Highly polished parts reduce friction, extend packing life, and avoid damage from corrosion and abrasion. More than 100,000 of these pumps are in operation around the world.

This PowrTwin offers other cost saving features:

- Freeze-proof pressure control
- Choice of power — gas, electric, or both
- Tungsten carbide reversible valve seats
- Self-adjusting packings
- Exclusive hand-tight swivel foot valve
- Large capacity inline paint filter
- Waterborne compatible
- "Floating Ball" pressure bleed valve
- 5 gallon siphon hose and bleed line assemblies are standard

You have made an excellent choice. We know you will be pleased with your new PowrTwin. Thanks again for selecting Speeflo. We appreciate your business.

Operation

Fueling (gas engine)

WARNING

Gasoline is extremely flammable and is explosive under certain conditions.

- ALWAYS turn the engine off before refueling.
- Refuel in a well-ventilated area.
- Do not smoke or allow flames or sparks in the refueling area or where gasoline is stored.
- Do not overfill the fuel tank. After refueling, make sure the tank cap is closed properly and securely.
- Be careful not to spill fuel when refueling. Spilled fuel or fuel vapor may ignite. If any fuel is spilled, make sure the area is dry before starting the engine.
- Avoid repeated or prolonged contact with skin or breathing of vapor.
- Keep out of the reach of children.

Fuel Specifications

- Use automotive gasoline that has a pump octane number of 86 or higher, or that has a research octane number of 91 or higher. Use of a lower octane gasoline can cause persistent "pinging" or heavy "spark knock" (a metallic rapping noise) which, if severe, can lead to engine damage.

NOTE: If "spark knock" or "pinging" occurs at a steady engine speed under normal load, change brands of gasoline. If spark knock or pinging persists, consult an authorized dealer of the engine manufacturer. Failure to do so is considered misuse, and damage caused by misuse is not covered by the engine manufacturer's limited warranty.

Occasionally you may experience light spark knock while operating under heavy loads. This is no cause for concern, it simply means your engine is operating efficiently.

- Unleaded fuel produces fewer engine and spark plug deposits and extends the life of the exhaust system components.
- Never use stale or contaminated gasoline or an oil/gasoline mixture. Avoid getting dirt, dust, or water in the fuel tank.

Gasolines Containing Alcohol

If you decide to use a gasoline containing alcohol (gasohol), be sure its octane rating is at least as high as that recommended by the engine manufacturer. There are two types of "gasohol": one containing ethanol, and the other containing methanol. Do not use gasohol that contains more than 10% ethanol. Do not use gasoline containing methanol (methyl or wood alcohol) that does not also contain co-solvents and corrosion inhibitors for methanol. Never use gasoline containing more than 5% methanol, even if it has co-solvents and corrosion inhibitors.

NOTE: Fuel system damage or engine performance problems resulting from the use of fuels that contain alcohol is not covered under the warranty. The engine manufacturer cannot endorse the use of fuels containing methanol since evidence of their suitability is incomplete at this time.

Before buying gasoline from an unfamiliar station, try to find out if the gasoline contains alcohol. If it does, confirm the type and percentage of alcohol used. If you notice any undesirable operating characteristics while using a gasoline that contains alcohol, or one that you think contains alcohol, switch to a gasoline that you know does not contain alcohol.

Setup

⚠ WARNING

Read, understand, and follow all warnings before starting or operating this sprayer.

1. Connect the siphon hose to the fluid section and the bleed hose to the bleed valve. They each have factory installed UV \O tape on the male end of the hoses and should be tightened wrench tight.

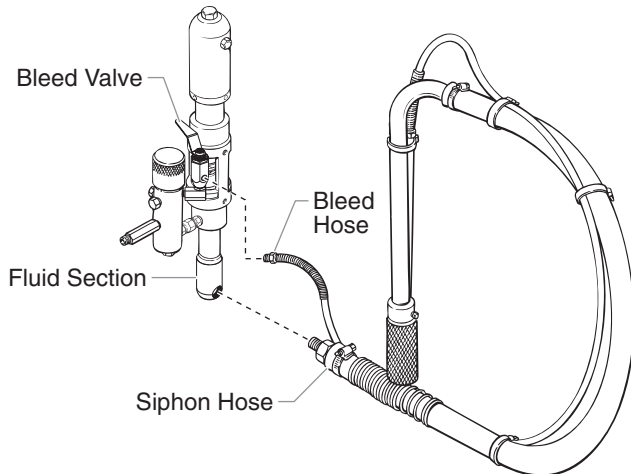

2. Attach a minimum of 50' of nylon airless spray hose to the unit. Do not use UV \O tape or thread sealant on the spray hose connection.
3. Attach an airless spray gun to the spray hose. Do not attach the tip to the spray gun yet. Remove the tip if it is already attached.
 - a. To use two guns, remove the plug from the second gun outlet on the filter assembly. Connect a hose and gun to the outlet.

NOTE: The gas unit is engineered to handle up to 6 guns with .024" tips and the electric unit is engineered to handle up to 3 guns with .019" tips. For multiple gun operation, connect a multiple gun manifold to the single gun outlet. Connect a hose and gun to each outlet. Make sure the second gun outlet remains plugged.

Multiple Gun Manifold

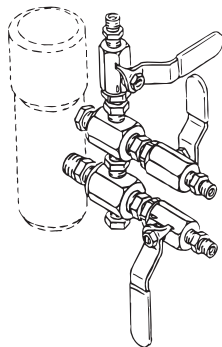

4. Fill the oil cup 1/2 full with Speeflo Piston Lube (P/N 314-480) supplied by the factory. This extends packing life.
5. Check the hydraulic fluid level daily before starting the unit. The hydraulic fluid level should be at the "Full" mark on the dipstick. Refer to the Maintenance section of this manual for hydraulic system maintenance instructions.

⚠ CAUTION

Use of Speeflo's Coolflo™ Hydraulic Fluid is mandatory in the hydraulic system. Do not use any other hydraulic fluid. Use of any other hydraulic fluid may seriously damage the hydraulic system and will void the warranty.

6. For gas models, check the engine oil level daily before starting the unit. The gasoline engine oil level is determined by the engine manufacturer. Refer to the engine manufacturer's service manual supplied with this unit.
7. For electric models, use a 20 amp service outlet. Always locate the electric model within 10 to 15 feet of the service outlet. Use a short electric cable and a long paint hose. Any extension cord will create some voltage drop. If an extension cord is necessary, use only a grounded 3-wire #12 extension cord.

NOTE: If the unit is being operated in an area that is overloaded by other appliances or low voltage conditions, it is important to start the unit "unloaded." Tip the electric motor forward so that the belt is loosened and the motor starts without full load. This reduces the amperage draw on starting and may avoid tripping the circuit breaker.

8. Make sure the unit is grounded. All units are equipped with a grounding lug. A grounding cable (not supplied) should be used to connect the unit to a true earth ground. Check your local electrical regulations for detailed grounding instructions. See the Accessories and Service Kits section near the back of this manual for grounding cable ordering information.

⚠ WARNING

Proper grounding is important. This applies to both gas and electric powered models. The passage of some materials through the nylon fluid hose will build up a static electric charge, which if discharged, could ignite solvent vapors present and create an explosion.

9. Strain all paints with a nylon strainer to ensure trouble free operation and freedom from frequent cleaning of the inlet screen and gun filter.
10. Make sure the spray area is well ventilated to prevent hazardous operation with volatile solvents or exhaust fumes.

⚠ WARNING

If lacquer or other flammable materials are to be sprayed, ALWAYS locate the unit outside the immediate spraying area. Failure to do so may cause an explosion.

11. Locate the unit outside the immediate spraying area to avoid clogged air intake of the engine or electric motor with overspray.

Preparing a New Sprayer

If this unit is new, it is shipped with test fluid in the fluid section to prevent corrosion during shipment and storage. This fluid must be thoroughly cleaned out of the system with mineral spirits before you begin spraying.

CAUTION

Always keep the trigger lock on the spray gun in the locked position while preparing the system.

1. Place the siphon hose into a container of mineral spirits.
2. Place the bleed hose into a metal waste container.
3. Set the pressure to minimum by turning the pressure control knob fully counterclockwise.

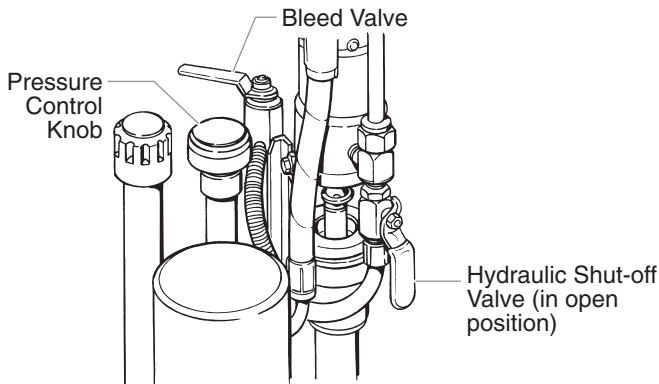

4. Open the hydraulic shut-off valve located on the hydraulic pressure hose. The handle should be in line with the hose.
5. Open the bleed valve by rotating the bleed valve handle fully counterclockwise.
6. Start the engine or turn on the electric motor.

a. To start the gas engine,

- move the fuel valve lever to the open position,
- move the throttle lever to its middle point,
- move the choke lever to the closed position for a cold engine or to the open position for a warm engine,
- turn the engine switch to the ON position, and
- pull the starter rope briskly until the engine starts.

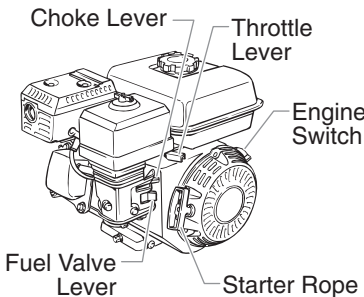

b. To start the electric motor, move the ON/OFF switch to the ON position.

7. Turn the pressure control knob clockwise approximately 1/3 of the way down to increase pressure until the sprayer cycles evenly and solvent flows freely from the bleed hose.
8. Allow the sprayer to run for 15–30 seconds to flush the test fluid out through the bleed hose and into the waste container.
9. Turn off the unit.
 - a. To turn off the gas engine,
 - set the pressure to minimum by turning the pressure control knob fully counterclockwise,
 - move the throttle lever to the slow position, and
 - turn the engine switch to the OFF position.
 - b. To turn off the electric motor,
 - set the pressure to minimum by turning the pressure control knob fully counterclockwise,
 - move the ON/OFF switch to the OFF position.

Preparing to Paint

Before painting, it is important to make sure that the fluid in the system is compatible with the paint that is going to be used.

NOTE: Incompatible fluids and paint may cause the valves to become stuck closed, which would require disassembly and cleaning of the sprayer's fluid section.

CAUTION

Always keep the trigger lock on the spray gun in the locked position while preparing the system.

1. Place the siphon hose into a container of the appropriate solvent.

NOTE: If you are spraying a water-based latex, flush with warm, clean water. If you are using any other material, check with the material manufacturer for a compatible solvent.

2. Place the bleed hose into a metal waste container.
3. Set the pressure to minimum by turning the pressure control knob fully counterclockwise.
4. Open the hydraulic shut-off valve located on the hydraulic pressure hose. The handle should be in line with the hose.
5. Open the bleed valve by rotating the bleed valve handle fully counterclockwise.
6. Start the engine or turn on the electric motor.
 - a. To start the gas engine,
 - move the fuel valve lever to the open position,
 - move the throttle lever to its middle point,
 - move the choke lever to the closed position for a cold engine or to the open position for a warm engine,
 - turn the engine switch to the ON position, and
 - pull the starter rope briskly until the engine starts.
 - b. To start the electric motor, move the ON/OFF switch to the ON position.
7. Turn the pressure control knob clockwise approximately 1/3 of the way down to increase pressure until the sprayer cycles evenly and solvent flows freely from the bleed hose.
8. Allow the sprayer to run for 15–30 seconds to flush the test fluid out through the bleed hose and into the waste container.
9. Turn off the unit.
 - a. To turn off the gas engine,
 - set the pressure to minimum by turning the pressure control knob fully counterclockwise,
 - move the throttle lever to the slow position, and
 - turn the engine switch to the OFF position.
 - b. To turn off the electric motor,
 - set the pressure to minimum by turning the pressure control knob fully counterclockwise,
 - move the ON/OFF switch to the OFF position.

NOTE: Make sure that the spray gun does not have a tip or tip guard installed.

10. Close the bleed valve by rotating the bleed valve handle fully clockwise.
11. Start the engine or turn on the electric motor.
12. Turn the pressure control knob clockwise approximately 1/3 of the way down to increase pressure.
13. Unlock the gun by turning the gun trigger lock to the unlocked position.

⚠️WARNING

Ground the gun by holding it against the edge of the metal container while flushing. Failure to do so may lead to a static electric discharge, which may cause a fire.



14. Trigger the gun into the metal waste container until the old solvent is gone and fresh solvent is coming out of the gun.
15. Lock the gun by turning the gun trigger lock to the locked position.
16. Set down the gun and increase the pressure by turning the pressure control knob slowly clockwise.
17. Check the entire system for leaks. If leaks occur, follow the "Pressure Relief Procedure" in this manual before tightening any fittings or hoses.
18. Follow the "Pressure Relief Procedure" in this manual before changing from solvent to paint.



Trigger lock in locked position.

⚠️WARNING

Be sure to follow the pressure relief procedure when shutting the unit down for any purpose, including servicing or adjusting any part of the spray system, changing or cleaning spray tips, or preparing for cleanup.

Painting

1. Place the siphon hose into a container of paint.
2. Place the bleed hose into a metal waste container.
3. Set the pressure to minimum by turning the pressure control knob fully counterclockwise.

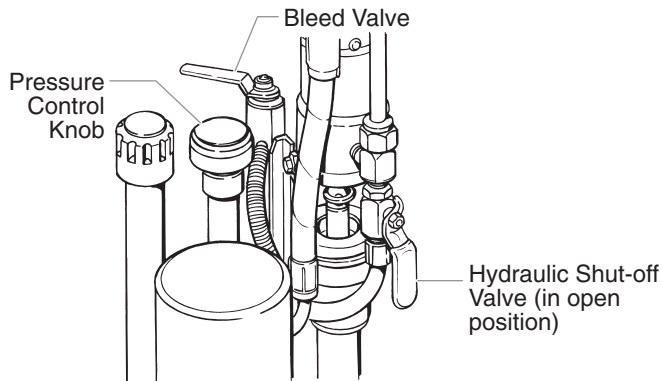

4. Open the hydraulic shut-off valve located on the hydraulic pressure hose. The handle should be in line with the hose.
5. Open the bleed valve by rotating the bleed valve handle fully counterclockwise.
6. Start the engine or turn on the electric motor.

a. To start the gas engine,

- move the fuel valve lever to the open position,
- move the throttle lever to its middle point,
- move the choke lever to the closed position for a cold engine or to the open position for a warm engine,
- turn the engine switch to the ON position, and
- pull the starter rope briskly until the engine starts.

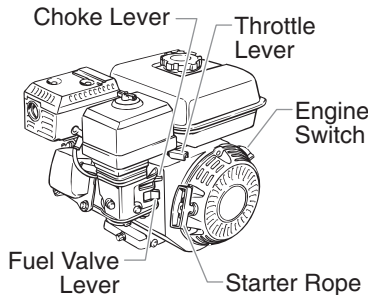

- b. To start the electric motor, move the ON/OFF switch to the ON position.
7. Turn the pressure control knob clockwise approximately 1/3 of the way down to increase pressure until the sprayer cycles evenly and paint flows freely from the bleed hose.
8. Turn off the unit.
 - a. To turn off the gas engine,
 - set the pressure to minimum by turning the pressure control knob fully counterclockwise,
 - move the throttle lever to the slow position, and
 - turn the engine switch to the OFF position.
 - b. To turn off the electric motor,
 - set the pressure to minimum by turning the pressure control knob fully counterclockwise,
 - move the ON/OFF switch to the OFF position.
9. Remove the bleed hose from the waste container and place it into the container of paint.
10. Close the bleed valve by rotating the bleed valve handle fully clockwise.
11. Start the engine or turn on the electric motor.
12. Turn the pressure control knob clockwise approximately 1/3 of the way down to increase pressure.
13. Unlock the gun by turning the gun trigger lock to the unlocked position.

⚠️WARNING

Ground the gun by holding it against the edge of the metal container while flushing. Failure to do so may lead to a static electric discharge, which may cause a fire.



14. Trigger the gun into the metal waste container until all air and solvent is flushed from the spray hose and paint is flowing freely from the gun.
15. Lock the gun by turning the gun trigger lock to the locked position.
16. Turn off the unit.
17. Attach tip guard and tip to the gun as instructed by the tip guard or tip manuals.



Trigger lock in locked position.

⚠️WARNING

POSSIBLE INJECTION HAZARD. Do not spray without the tip guard in place. Never trigger the gun unless the tip is in either the spray or the unclog position. Always engage the gun trigger lock before removing, replacing or cleaning tip.

18. Start the engine or turn on the electric motor.
19. Increase the pressure by turning the pressure control knob slowly clockwise and test the spray pattern on a piece of cardboard. Adjust the pressure control knob until the spray from the gun is completely atomized.

NOTE: Turning the pressure up higher than needed to atomize the paint will cause premature tip wear and additional overspray.

Pressure Relief Procedure

⚠ WARNING

Be sure to follow the pressure relief procedure when shutting the unit down for any purpose, including servicing or adjusting any part of the spray system, changing or cleaning spray tips, or preparing for cleanup.

1. Lock the gun by turning the gun trigger lock to the locked position.
2. Turn off the unit.
 - a. To turn off the gas engine,
 - set the pressure to minimum by turning the pressure control knob fully counterclockwise,
 - move the throttle lever to the slow position, and
 - turn the engine switch to the OFF position.
 - b. To turn off the electric motor,
 - set the pressure to minimum by turning the pressure control knob fully counterclockwise,
 - move the ON/OFF switch to the OFF position.
3. Close the hydraulic shut-off valve on the hydraulic pressure hose.
4. Unlock the gun by turning the gun trigger lock to the unlocked position.
5. Hold the metal part of the gun firmly to the side of a metal waste container to ground the gun and avoid a build up of static electricity.
6. Trigger the gun to remove any pressure that may still be in the hose.
7. Lock the gun by turning the gun trigger lock to the locked position.
8. Place the bleed hose into the metal waste container.
9. Open the bleed valve by rotating the bleed valve handle fully counterclockwise.

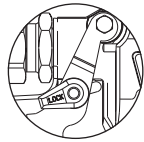

Trigger lock in locked position.



3. Place the siphon tube into a container of the appropriate solvent.

⚠ CAUTION

Use only compatible solvents when cleaning out oil based enamels, lacquers, coal tar, and epoxies. Check with the fluid manufacturer for the recommended solvent.

4. Place the bleed hose into a metal waste container.
5. Set the pressure to minimum by turning the pressure control knob fully counterclockwise.

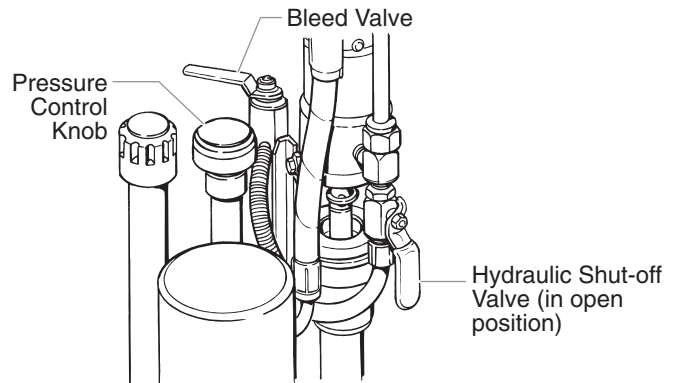

6. Open the hydraulic shut-off valve located on the hydraulic pressure hose. The handle should be in line with the hose.
7. Open the bleed valve by rotating the bleed valve handle fully counterclockwise.
8. Start the engine or turn on the electric motor.
9. Allow the solvent to circulate through the unit and flush the paint out of the bleed hose into the metal waste container.
10. Turn off the unit.
11. Close the bleed valve by rotating the bleed valve handle fully clockwise.
12. Start the engine or turn on the electric motor.

Cleanup

⚠ WARNING

Special cleanup instructions for use with flammable solvents:

- Always flush spray gun preferably outside and at least one hose length from spray pump.
- If collecting flushed solvents in a one gallon metal container, place it into an empty five gallon container, then flush solvents.
- Area must be free of flammable vapors.
- Follow all cleanup instructions.

⚠ CAUTION

The sprayer, hose, and gun should be cleaned thoroughly after daily use. Failure to do so permits material to build up, seriously affecting the performance of the unit.

⚠ WARNING

Always spray at minimum pressure with the gun nozzle tip removed when using mineral spirits or any other solvent to clean the sprayer, hose, or gun. Static electricity buildup may result in a fire or explosion in the presence of flammable vapors.

1. Follow the "Pressure Relief Procedure" found in the Operation section of this manual.
2. Remove the gun tip and tip guard and clean with a brush using the appropriate solvent.

⚠ WARNING

Ground the gun by holding it against the edge of the metal container while flushing. Failure to do so may lead to a static electric discharge, which may cause a fire.



13. Trigger the gun into the metal waste container until the paint is flushed out of the hose and solvent is coming out of the gun.
14. Continue to trigger the spray gun into the waste container until the solvent coming out of the gun is clean.

NOTE: For long-term or cold weather storage, pump mineral spirits through the entire system.

15. Follow the "Pressure Relief Procedure" found in the Operation section of this manual.
16. Store the unit in a clean, dry area.

⚠ CAUTION

Do not store the unit under pressure.

Cleaning a Clogged Tip

1. Follow the "Pressure Relief Procedure" in the Operation section of this manual.
2. If the tip clogs, rotate the tip handle 180° until the arrow on the handle is facing the opposite of the spray direction and the handle clicks in the reverse position.
3. Trigger the gun once so that the pressure can blow the clog out. NEVER use the tip in the reverse position for more than ONE trigger pull at a time. This procedure can be repeated until the tip is free of clogging.

WARNING

The flow from the spray tip is at very high pressure. Contact with any body part may be dangerous. Do not place finger on gun outlet. Do not point the gun at any person. Never operate the spray gun without the proper tip guard.

Maintenance

WARNING

Before proceeding, follow the Pressure Relief Procedure outlined previously in this manual. Additionally, follow all other warnings to reduce the risk of an injection injury, injury from moving parts or electric shock. Always unplug the sprayer before servicing!

Daily Maintenance

Two daily procedures are required for routine operator maintenance on this unit:

1. Lubricating the upper packings.
2. Cleaning the rock catcher.

Lubricating the Upper Packings

1. Clean out the paint that has seeped past the upper packings into the packing oil cup above the fluid section.
2. Fill the packing oil cup 1/2 full with Piston Lube (P/N 314-480) supplied by the factory. This will extend packing life.

NOTE: Do not over-fill the oil cup so that it overflows and drips into the paint.

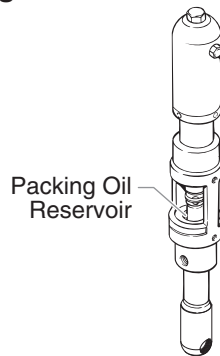

Cleaning the Rock Catcher

1. The rock catcher will clog and must be cleaned at least once a day.
2. Loosen the nut that secures the rock catcher to the siphon tube.
3. Remove the rock catcher from the bottom of the siphon tube.
4. Clean thoroughly with the appropriate solvent.

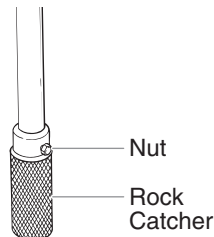

Maintaining the Filter Assembly

Clean the filter regularly. Dirty or clogged filters can greatly reduce filtering ability and cause a number of system problems including poor spray patterns, clogged spray tips, etc.

Cleaning

To clean the filter, perform the following procedure.

1. Follow the "Pressure Relief Procedure" found in the Operation section of this manual.
2. Remove the filter cap assembly and spring.
3. Pull the filter element with ball straight out of the filter body.
4. Clean inside the filter body, filter element with ball, and filter cap assembly using the appropriate solvent.

NOTE: Use care in handling parts as dirt, debris, scratches, or nicks may prevent o-rings or gaskets from sealing. This filter element filters from the inside out. Be sure to clean the filter element thoroughly on the inside. Soak in solvent to loosen hardened paint or replace.

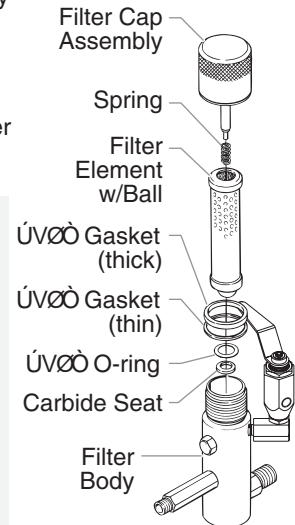

Inspection

Inspect all parts of the filter assembly before reassembly.

1. Inspect the ball inside the filter element. If the ball has pressure cuts or scratches, replace the filter element.
 - a. If the ball is cut, remove the O-ring using an o-ring pick and remove the carbide seat.
 - b. Check the seat for nicks or grooves. If the seat is damaged, replace.

NOTE: Removal of the DH: 9 o-ring will damage the o-ring and require replacement.

2. Remove the spring from the spring guide on the filter cap.
 - a. Measure the length of the spring uncompressed. If it measures less the 3/4" from end to end, replace.
 - b. Push the spring back onto the spring guide until it "snaps" back into position.
3. Inspect the two O-rings and the O-ring for deformity, nicks, or cuts. Replace, if needed.

NOTE: The DH: 9 gaskets, DH: 9 o-ring, and spring are packaged in Filter Service Kit P/N 930-050.

Reassembly

After cleaning and inspecting all parts, reassemble the filter.

1. Place the carbide seat into the filter body. Make sure the beveled side of the seat is facing up.
2. Place the O-ring into the groove on the outer diameter of the carbide seat.
3. Place the filter element with ball into the filter body.

NOTE: The top and bottom of the filter element with ball are identical.

4. Push the spring back onto the spring guide of the filter cap until it "snaps" back into position, if not already done.
5. Place the thin O-ring onto the step at the top of the filter body.
6. Place the thick O-ring onto the top of the thin gasket.
7. Tighten the filter cap assembly onto the filter body.

Maintaining the Hydraulic System

CAUTION

Use of Speeflo's Coolflo™ Hydraulic Fluid is mandatory in the PowrTwin hydraulic system. Do not use any other hydraulic fluid. Use of any other hydraulic fluid may seriously damage the hydraulic system and will void the warranty.

1. Check the hydraulic fluid daily. It should be at the "Full" mark on the dipstick. If it is low, add only Speeflo Coolflo™ Hydraulic Fluid (P/N 430-361). Never add or change hydraulic fluid except in a clean, dust-free area. Contamination of the hydraulic fluid will shorten hydraulic pump life and may void warranty.

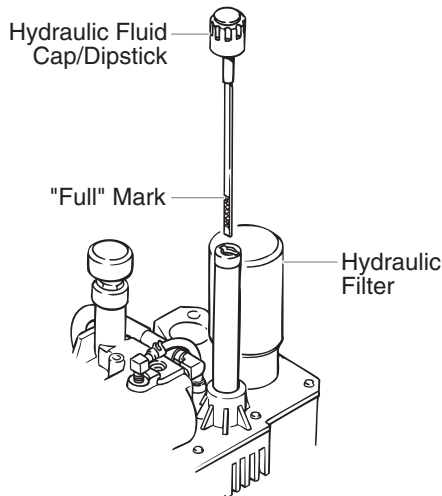

2. Change the hydraulic fluid every twelve months. Drain the old fluid from the tank and fill with 5 quarts of Speeflo Coolflo™ Hydraulic Fluid (6 quarts when also replacing the hydraulic filter). Start the unit at just enough pressure to operate the fluid section. Run the unit at this low pressure for at least 5 minutes. This removes air from the system. Check the fluid level after this procedure.
3. The hydraulic system has an external, replaceable hydraulic filter. Change the filter every twelve months.
4. The hydraulic pump should not be serviced in the field. If service on the hydraulic pump is required, it must be returned to Speeflo.

Maintaining the Fluid Section

If the sprayer is going to be out of service for an extended period of time, it is recommended that following cleanup, a kerosene and oil mixture be introduced as a preservative. Packings may tend to dry out from lack of use. This is particularly true of the upper packing set for which upper packing lubricant Piston Lube (P/N 314-480) is recommended in normal usage.

If the sprayer has been out of service for an extended period of time, it may be necessary to prime the suction by pouring some of the paint solvent into the siphon tube to restart. It is extremely important that the threads on the siphon hose coupling are properly sealed. Any air leakage will produce erratic operation of the sprayer and may damage the system. The up and the down strokes should be approximately equal in time (one should not be faster than the other). A fast up or down stroke may indicate air in the system or malfunctioning valve or seats (see the Troubleshooting section).

Basic Engine Maintenance (gas engine)

- For detailed engine maintenance and technical specifications refer to the separate gasoline engine manual.
- All service to the engine should be performed by an authorized Honda Power Equipment dealer. To locate a dealer in your area, look in the Yellow Pages of your telephone directory under Gasoline Engines, Garden & Lawn Equipment & Supplies, Lawn Mowers, etc.
- The Honda engine is warranted exclusively by American Honda Motor Co., Inc.
- Use a premium quality motor oil certified to meet or exceed U.S. Automotive requirement SG or SF. SAE 10W30 is recommended for general all temperature use. Other viscosities may be required in other climates.
- Use only a (NGK) BP6ES or BPR6E spark plug. Gap the plug to 0.028 to 0.031 In. (0.7 to 0.8 mm) Always use a spark plug wrench.

Daily

1. Check engine oil level, and fill as necessary.
2. Check gasoline level, and fill as necessary.

WARNING

Always follow the fueling procedure outlined earlier in this manual.

First 20 Hours

1. Change engine oil.

Every 100 Hours

1. Change engine oil.
2. Clean the sediment cup.
3. Clean and re-gap the spark plug.
4. Clean the spark arrestor.

Weekly

1. Remove the air filter cover and clean the element. In very dusty environments, check the filter daily. Replace the element as needed. Replacement elements can be purchased from your local Honda dealer.

Engine Operation and Service

1. Clean and oil air filter pad on gasoline engine every 25 hours or once weekly. Do not permit the air intake screen around the fly wheel of the gas engine to load up with paint or trash. Clean it regularly. The service life and efficiency of the gas engine model depends upon keeping the gasoline engine running properly. Change the oil in the engine every 100 hours. Failure to observe this may result in engine overheating. Consult the engine manufacturer's service manual provided.
2. To conserve fuel, service life, and efficiency of the unit, always operate the gasoline engine at the lowest RPM at which it runs smoothly without laboring and delivers the amount required for the particular painting operation. Higher RPM does not produce higher working pressure. The gasoline engine is connected to the hydraulic pump by a pulley combination designed to produce full paint delivery at maximum RPM.
3. The warranty on gasoline engines or electric motors is limited to the original manufacturer.

Replacing the Motor Brushes (electric motor)

Perform this procedure using Motor Brush Kit P/N 978-050. The kit consists of two brushes, two springs, and two clips.

NOTE: Brushes should be replaced when they are worn to less than 1/2 inch. Check and replace both brushes at the same time.

1. Remove both inspection covers on the motor.

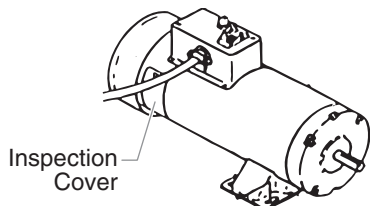

2. Push in the spring clip to unhook it, then pull it out..

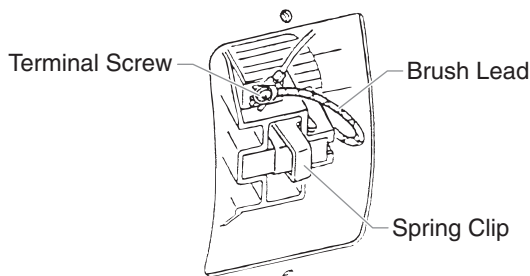

3. Loosen the terminal screw. Pull the brush lead away, but leave the motor lead in place. Remove the brush and spring.
4. Inspect the commutator for burning, excessive pitting or gouging. A black color on the commutator is normal.

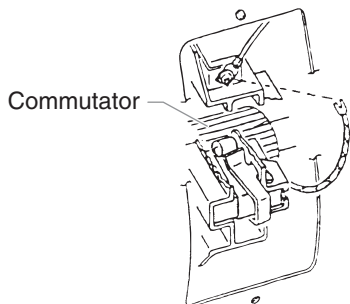

5. Install the new brush so its lead slides in the long slot of the brush holder. Push the terminal under the terminal screw washer. Ensure the motor lead is still connected at the screw. Tighten the screw.

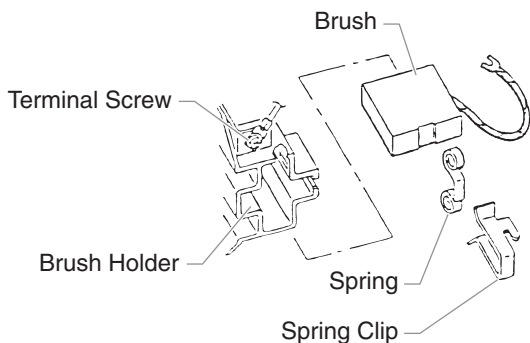

6. Place the spring on the brush as shown above. Push in and hook the spring clip. Repeat this procedure for the other side.
7. Reinstall both inspection covers.

WARNING

If electric motor overloads and stops running, **IMMEDIATELY** turn the motor off and follow the Pressure Relief Procedure in the Cleanup section of this manual. Wait until the motor cools (approximately 30 minutes). Then push in the bubble top, manual reset button, turn the motor on and pressurize the system.

For CSA approved units only: The ON/OFF switch is also the RESET!

Troubleshooting

Airless Gun

Problem

Spitting gun

Cause

1. Air in system
2. Dirty gun
3. Needle assembly out of adjustment
4. Broken or chipped seat

Solution

1. Inspect connections for air leaks.
2. Disassemble and clean.
3. Inspect and adjust.
4. Inspect and replace.

Gun will not shut off

1. Worn or broken needle & seat
2. Needle assembly out of adjustment
3. Dirty gun

1. Replace.
2. Adjust.
3. Clean.

Gun does not spray

1. No paint
2. Plugged filter or tip
3. Broken needle in gun

1. Check fluid supply.
2. Clean.
3. Replace.

Fluid Section

Problem

Pump delivers on upstroke only or goes up slowly and down fast (commonly called downstroke dive)

Cause

1. Lower foot valve ball is not seating due to trash or wear
2. Material too viscous to siphon.
3. Air leaking in on siphon side or damaged siphon hose. Siphon may be too small for heavy material.

Solution

1. Remove foot valve assembly. Clean and inspect. Test foot valve by filling with water; if ball fails to seal the seat, replace ball.
2. Thin material — contact manufacturer for proper thinning procedures.
3. Tighten all connections between pump and paint container. If damaged, replace. Switch to larger diameter siphon set.

Pump delivers on down stroke only or goes up fast and down slowly

1. Upper ball is not seating due to trash or wear
2. Lower packing set is worn

1. Check upper seat and ball with water. If ball fails to seal, replace seat.
2. Replace packing set if worn.

Pump moves up and down fast, delivering material

1. Material container is empty or material is too thick to flow through siphon hose
2. Bottom ball stuck to foot valve seat
3. Siphon hose is kinked or loose

1. Refill with new material. If too thick, remove siphon hose, immerse fluid section in material, and start pump to prime. Add thinner to material. Change to bigger siphon set. Open bleed valve to remove air and restart pump.
2. Remove foot valve. Clean ball and seat.
3. Straighten.

Pump moves up and down slowly when spray gun is shut off

1. Loose connections. Bleed valve is open partially or bleed valve is worn. Lower packing seat is worn.
2. Upper and/or lower ball not seating

1. Check all connections between pump and gun. Tighten as necessary. If material is flowing from bleed hose, close bleed valve or replace, if necessary. Should none of the above be evident, replace lower packing.
2. Reseat balls by cleaning.

Not enough fluid pressure at gun

1. Spray tip is worn
2. Outlet filter or gun filter is clogged
3. Low voltage and/or inadequate amperage
4. Hose size or length is too small or too long

1. Replace.
2. Clean or replace filter.
3. Check electrical service. Correct as required.
4. Increase hose size to minimize pressure drop through hose and/or reduce hose length.

Pump chatters on up or down stroke

1. Solvent has caused upper packing to swell

1. Replace packing.

Troubleshooting

Hydraulic Motor

Problem

Oil motor stalls at bottom (no unusual heat problems)

Cause

1. Fluid pump piston seat unthreaded
2. Valve sticking or oil motor trip rod shifter assembly separated

Solution

1. If connecting rod is okay, remove cylinder head plug and pop valve down. Replace plug and start machine. If machine cycles up and stops at bottom again, then problem is piston seat on fluid pump. Check piston seat. Repair or replace as necessary. If piston seat is okay and problem does not change, check oil motor.
2. Remove valve and check for scratches and rough movement when sliding it up and down. Replace valve and spool in this condition. Check trip rod for possible separation and spool in this condition. Check trip rod for possible separation.

Oil motor stalls at top (no unusual heat problems)

1. Valve sticking
2. Broken spring retainer (valve rod assembly)
3. Broken spring or valve rod
4. Air in hydraulic motor

1. Remove valve and check for scratches and rough movement when sliding it up and down. Replace valve and spool in this condition.
2. Replace valve rod assembly.
3. Replace valve rod assembly.
4. Reset valve. Purge Air, generally accomplished by low pressure cycling of motor/pump assembly for 5–10 minutes. Check for causes of air introduction:
 - Loose fittings in tank.
 - Loose fittings on hydraulic pump.
 - Loose hose connections.
 - Low oil in reservoir.
5. Stall at top can occur randomly when fluid pump picks up air. Reset valve. Avoid air in the fluid pump.

Low pressure (okay on down stroke, sluggish on up.stroke — high heat)

NOTE: Engine labors on upstroke, idles back at stall on the down stroke.

1. Blown piston seal
2. Cracked piston

1. Before dismantling oil motor, start machine. With pump cycling under pressure, touch the hydraulic cylinder and the head to see if cylinder or head gets hotter. This will help determine if piston seal is blown or piston nut is broken. If heat is on the head, check the o-rings on spool valve.
2. Dismantle oil motor and check piston seals cylinder bore and piston nut. Pay special attention to piston nut. It can be cracked and not show externally.

Low pressure (both strokes - high heat)

NOTE: Engine labors at stall on both strokes.

1. Blown center o-rings on spool valve
2. Bad hydraulic pump

1. Before dismantling oil motor, start machine. With pump cycling under pressure, touch the head to see if the head becomes hotter. This will help determine if center o-ring is blown on spool valve. If hot, remove and replace o-ring.
2. Replace hydraulic pump.

Troubleshooting

Spray Patterns

Problem

Tails

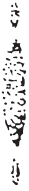

Cause

1. Inadequate fluid delivery

Solution

1. Fluid not atomizing correctly:
Increase fluid pressure. Change to smaller tip orifice size. Reduce fluid viscosity. Reduce hose length. Clean gun and filter(s). Reduce number of guns using pump.

Hour glass

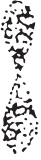

1. Inadequate fluid delivery

1. Same as above.

Distorted



1. Plugged or worn nozzle tip

1. Clean or replace nozzle tip.

Pattern expanding and contracting (surge)



1. Suction leak
2. Pulsating fluid delivery

1. Inspect for suction hose leak.
2. Change to a smaller tip orifice size. Install pulsation dampener in system or drain existing one. Reduce number of guns using pump. Remove restrictions in system; clean tip screen if filter is used.

Round pattern



1. Worn tip
2. Fluid too heavy for tip

1. Replace tip.
2. Increase pressure. Thin material. Change nozzle tip.

Consignes de sécurité

Le présent manuel contient des renseignements à lire attentivement et à bien comprendre avant d'utiliser l'équipement. Lorsque l'un des symboles suivants apparaît, il est recommandé d'être particulièrement attentif et de tenir compte des mesures de sécurité indiquées.

AVERTISSEMENT

Ce symbole indique un risque potentiel susceptible d'entraîner des blessures graves, voire mortelles. Vous trouverez ci-après des renseignements importants concernant la sécurité.

ATTENTION

Ce symbole indique un risque potentiel pour l'utilisateur ou l'équipement. Vous trouverez ci-après des renseignements importants sur la manière d'éviter d'endommager l'équipement ou d'éviter de provoquer des blessures superficielles.

NOTA : Les remarques vous procurent des renseignements importants auxquels il faut faire particulièrement attention.

AVERTISSEMENT

DANGER : Danger de blessure par perforation – Le flux à haute pression produit par cet équipement peut percer la peau et les tissus sous-cutanés et provoquer des blessures graves voire une amputation. Consultez immédiatement un médecin.

NE TRAITÉZ PAS UNE BLESSURE PAR PERFORATION SOUS-CUTANÉE COMME UNE SIMPLE COUPURE! Une perforation sous-cutanée peut entraîner l'amputation du membre touché. Consultez immédiatement un médecin.

La pression de liquide maximale de fonctionnement du pistolet est de 3 300 PSI (22.8 MPa).

PRÉVENTION:

- Ne dirigez JAMAIS le pistolet vers une partie du corps.
- Ne laissez JAMAIS une quelconque partie du corps entrer en contact avec le jet de liquide. Ne laissez JAMAIS le corps entrer en contact avec une fuite dans le tuyau de liquide.
- Ne placez JAMAIS votre main devant le pistolet. Portez des gants pour vous éviter toute blessure par perforation.
- Bloquez TOUJOURS la gâchette du pistolet, éteignez la pompe et vidangez toute la pression avant toute opération d'entretien, avant de nettoyer une buse ou une protection, avant de changer une buse ou si vous laissez l'appareil sans surveillance. La pression ne s'évacue pas simplement en éteignant le moteur. La vanne d'AMORÇAGE / VAPORISATION ou la vanne de décharge de la pression doivent être placées dans les positions souhaitées pour vidanger la pression. Consultez la PROCÉDURE DE DECHARGE DE PRESSION décrite dans ce manuel.
- Placez TOUJOURS la protection de l'embout lorsque vous pulvérisez. Celui-ci fournit une certaine protection, mais il est avant tout un dispositif de prévention.
- Démontez TOUJOURS l'embout de pulvérisation avant de purger ou de nettoyer le circuit.
- Le tuyau de peinture peut présenter des fuites s'il est usé, tordu ou endommagé. Une fuite peut projeter de la peinture sur la peau et causer une perforation sous-cutanée. Vérifiez soigneusement le tuyau avant chaque utilisation.
- N'utilisez JAMAIS un pistolet de pulvérisation qui ne dispose pas d'un dispositif de blocage de gâchette ou d'une protection de gâchette en bon état de fonctionnement.
- Tous les accessoires doivent pouvoir travailler à la pression de travail maximale du pulvérisateur ou au-dessus. Ceci concerne les buses de pulvérisation, les pistolets, les rallonges et le tuyau.

REMARQUE POUR LE MÉDECIN:

Une perforation sous-cutanée constitue un traumatisme. Il est important de traiter la blessure le plus tôt possible. NE retardez PAS le traitement pour des recherches de toxicité. La toxicité n'est préoccupante que lorsque certaines peintures pénètrent dans le flux sanguin. Il peut être recommandé de consulter un chirurgien plastique ou un spécialiste de chirurgie reconstructrice de la main.

DANGER : RISQUES D'EXPLOSION OU D'INCENDIE – Les émanations de solvants et de peinture sont explosives et inflammables. Elles peuvent causer des blessures corporelles ou des dommages matériels importants.

PRÉVENTION:

- Veillez à éviter toute accumulation de vapeurs inflammables en vous assurant que la zone de pulvérisation est suffisamment ventilée.
- Veillez à éviter la présence de toute source incandescente comme les étincelles électrostatiques, la flamme nue, les pilotes et les objets chauds. Le branchement ou le débranchement de câbles électriques ou de lampes de travail peut produire des étincelles.
- Ne fumez pas dans la zone de pulvérisation.
- Ayez toujours un extincteur en bon état de marche à portée de main.
- Gardez l'appareil dans un endroit sec et bien aéré. Les vapeurs inflammables sont souvent plus denses que l'air. La zone proche du sol doit être extrêmement bien ventilée. La pompe à peinture contient des pièces susceptibles de former des arcs électriques qui peuvent émettre des étincelles et enflammer les vapeurs.
- L'équipement utilisé de même que les objets se trouvent à proximité de la zone de pulvérisation doivent être correctement mis à la terre pour éviter la formation d'étincelles électrostatiques.
- N'utilisez qu'un tuyau de liquide à haute pression conducteur ou relié à la terre. Le pistolet doit être relié à la masse par les branchements de tuyaux.
- Le cordon d'alimentation doit être raccordé à un circuit mis à la terre (modèles électriques uniquement).
- Vidangez toujours l'appareil dans un contenant métallique séparé, à une faible pression et avec l'embout de pulvérisation enlevé. Tenez fermement le pistolet contre le côté du contenant pour relier le contenant à la masse et éviter la formation d'étincelles électrostatiques.
- Suivez les instructions et les mises en garde du fabricant du solvant.
- Redoublez d'attention lorsque vous utilisez des matériaux dont le point d'éclair est inférieur à 70°F (21°C). Le point d'éclair est la température à laquelle un liquide peut produire assez de vapeurs pour s'enflammer.
- Les plastiques peuvent produire des étincelles électrostatiques. Ne jamais accrocher de revêtement en plastique pour fermer la zone de pulvérisation. N'utilisez pas de vêtements en plastiques lorsque vous pulvérisez des matériaux inflammables.
- Utilisez la plus petite pression possible pour rincer l'équipement.

MOTEUR ESSENCE (SI APPLICABLE)

Placez toujours la pompe à l'extérieur à l'air libre. Éloignez tous les solvants du conduit d'échappement du moteur. Ne remplissez jamais le réservoir de carburant lorsque le moteur est en marche ou chaud. Le carburant répandu au sol peut s'enflammer au contact de surfaces chaudes. Fixez toujours un câble de mise à la terre entre la pompe et un objet mis à la terre, comme un tuyau à eau métallique. Veuillez consulter le manuel de l'utilisateur du moteur pour de plus amples renseignements concernant les consignes de sécurité.

DANGER : RISQUE D'EXPLOSION EN RAISON DE MATÉRIAUX INCOMPATIBLES – Peut entraîner des dommages matériels ou des blessures graves.

PRÉVENTION:

- N'utilisez pas de matériaux contenant de l'eau de javel ou du chlore.
- N'utilisez pas de solvants aux hydrocarbures halogénés tels que des agents antimoisissure, du chlorure de méthylène, et du trichloroéthane 1,1,1. Ils ne sont pas compatibles avec l'aluminium.
- Communiquez avec votre fournisseur de peinture pour plus de détails concernant la compatibilité des matériaux avec l'aluminium.

DANGER : VAPEURS TOXIQUES – Les peintures, solvants, insecticides et autres produits peuvent s'avérer toxiques en cas d'inhalation ou de contact avec la peau. Les vapeurs peuvent entraîner des nausées, des pertes de conscience ou des empoisonnements.

PRÉVENTION:

- Utilisez un masque de protection si des vapeurs peuvent être inhalées. Lisez attentivement toutes les instructions fournies avec le masque pour vous assurer qu'il vous apportera bien toute la protection nécessaire.
- Portez un masque de protection.
- Portez des vêtements de protection, selon les instructions du fabricant de peinture.

DANGER : GÉNÉRALITÉ – Ce produit peut provoquer des blessures ou des dégâts matériels graves.

PRÉVENTION:

- Lisez attentivement toutes les instructions et les consignes de sécurité avant de faire fonctionner l'appareil.
- Débranchez toujours le moteur de la source d'alimentation électrique avant de travailler avec l'équipement (modèles électriques uniquement).
- Respectez attentivement toutes les réglementations locales, provinciales et fédérales concernant la ventilation, la prévention des incendies et les conditions d'utilisation.
- Les normes de sécurité du gouvernement américain sont régies par la Occupational Safety and Health Act (OSHA). Il est important de consulter ces normes, en particulier la section 1910 sur les normes générales et la section 1926 sur les normes de la construction.
- N'utilisez que des pièces autorisées par le fabricant. L'utilisateur sera tenu responsable de tout dommage subi s'il utilise des pièces non conformes aux caractéristiques minimales et aux consignes de sécurité du fabricant de la pompe.
- Avant chaque utilisation, vérifiez tous les tuyaux et recherchez toute trace d'entaille, de coupure, de fuite, d'abrasion. Assurez-vous également que le couvercle n'est pas bombé. Vérifiez l'état ou le mouvement des joints. Remplacez immédiatement le tuyau s'il présente l'un de ces défauts. Ne réparez jamais un tuyau à peinture. Remplacez-le par un autre tuyau à haute pression mis à la terre.
- Ne pulvérisez jamais à l'extérieur lorsqu'il vente.
- Portez des vêtements de protection pour protéger votre corps et vos cheveux des éclaboussures de peinture.

Instructions de mise à la terre

Les modèles électriques doivent être reliés à la terre. En cas de court-circuit électrique, la mise à la terre réduit les risques de choc électrique en fournissant un fil d'évacuation pour le courant électrique. Ce produit est équipé d'un cordon comportant un fil de mise à la terre et une fiche de mise à la terre appropriée. La fiche doit être branchée dans une prise correctement installée et reliée à la terre conformément aux codes et aux règlements locaux en vigueur.

DANGER – Une installation incorrecte de la fiche de mise à la terre risque de provoquer un choc électrique. Si vous devez réparer ou remplacer le cordon ou la fiche d'alimentation, ne branchez pas un fil de mise à la terre vert à une borne à broche plate. Le fil comportant un isolant de couleur verte, avec ou sans ligne jaune, est le fil de mise à la terre et doit être branché à la broche de mise à la terre.

Consultez un électricien qualifié ou un technicien d'entretien si vous n'avez pas totalement compris les instructions de mise à la terre ou si vous avez un doute concernant le branchement de l'appareil à la terre. Ne modifiez pas la prise fournie. Si la fiche n'entre pas dans la prise murale, faites installer une prise murale par un électricien qualifié.

Ce produit fonctionne à plus de 15 ampères et doit être utilisé sur un circuit avec une tension nominale de 120 volts, ou doit être utilisé sur un circuit avec une tension nominale supérieure à 120 volts, et est équipé en usine d'un cordon électrique spécifique et d'une fiche qui permettent de le brancher sur un circuit électrique approprié. Assurez-vous que le produit est bien branché dans une prise ayant la même configuration que la fiche. Aucun adaptateur ne doit être utilisé avec cet appareil. Si l'appareil doit être rebranché pour être utilisé sur un type de circuit électrique différent, le nouveau branchement doit être réalisé par un technicien qualifié



N'utilisez qu'un câble de rallonge trifilaire muni d'une fiche de mise à la terre de trois lames et d'une prise à trois orifices dans laquelle peut être branchée la fiche du produit. Assurez-vous que la rallonge est bien en bon état. Lorsque vous utilisez une rallonge, assurez-vous qu'elle convient au courant consommé par l'appareil. Une rallonge de section inférieure produira une perte de tension, et par conséquent une perte de puissance et une surchauffe. Une rallonge de calibre no 12 est recommandée pour des longueurs inférieures à 15,3 mètres (50 pieds). Si votre rallonge doit être utilisée à l'extérieur, le suffixe W-A doit apparaître après la désignation du type de câble. Par exemple, la désignation SJTW-A indiquerait que le câble peut être utilisé à l'extérieur.

Sécurité des moteurs à essence



Les produits chimiques contenus dans les vapeurs d'échappement de cet appareil sont reconnus par l'État de la Californie (États-Unis) comme étant cancérigènes. Ils peuvent également entraîner des anomalies congénitales ou d'autres dangers pour la santé.

1. Les moteurs Honda sont conçus pour fonctionner en toute sécurité et avec une fiabilité maximale s'ils sont utilisés conformément aux instructions. Veuillez lire et comprendre le manuel de l'utilisateur de Honda avant de faire fonctionner le moteur. Le non-respect de ces consignes peut entraîner des dommages matériels ou des blessures physiques graves.
2. Pour éviter tout risque d'incendie et fournir une ventilation adéquate, placez le moteur à une distance minimale de 1 mètre (3 pieds) des immeubles et d'autres équipements pendant son fonctionnement. Ne placez pas d'objets inflammables à côté du moteur.
3. Tenez les enfants et les animaux domestiques à l'écart de la zone de travail; vous éviterez ainsi tout risque de brûlures sur les pièces chaudes du moteur et de blessures entraînées par les accessoires utilisés par le moteur pour son fonctionnement.
4. Sachez comment arrêter rapidement le moteur, et assurez-vous que vous avez bien compris le fonctionnement de toutes les commandes. Ne permettez jamais à une personne de faire fonctionner le moteur sans connaître les instructions nécessaires.
5. L'essence est extrêmement inflammable et explosive dans certaines conditions.
6. Remplissez le réservoir de carburant dans une zone bien ventilée, moteur arrêté. Ne fumez pas et évitez toutes flammes ou étincelles dans la zone de remplissage de carburant ou dans une zone de stockage du carburant.
7. Veillez à ne pas faire déborder le réservoir de carburant. Après remplissage, assurez-vous que le bouchon du réservoir est solidement vissé.
8. Faites attention à ne pas renverser de carburant lors du remplissage du réservoir. Les vapeurs ou les éclaboussures de carburant peuvent s'enflammer. En cas d'éclaboussures, assurez-vous que la zone est bien sèche avant de faire démarrer le moteur.
9. Ne faites jamais fonctionner le moteur dans un endroit fermé ou confiné. Les fumées d'échappement contiennent du monoxyde de carbone qui est un gaz toxique; une exposition prolongée peut entraîner une perte de conscience et peut s'avérer mortelle.
10. Le silencieux devient très chaud pendant le fonctionnement et reste chaud quelque temps après l'arrêt du moteur. Faites attention à ne pas toucher le silencieux tant qu'il est chaud. Pour éviter des brûlures graves ou des risques d'incendie, laissez le moteur refroidir avant de le transporter ou de le ranger à l'intérieur.
11. Ne transportez jamais le moteur si le réservoir est plein.



N'utilisez PAS cet appareil pour pulvériser de l'eau ou de l'acide.



Ne soulevez pas l'appareil par la poignée du chariot pour le charger ou le décharger.

Precauciones de seguridad

Este manual contiene información que debe leer y comprender antes de usar el equipo. Cuando se encuentre con uno de los siguientes símbolos, preste especial atención y observe sus indicaciones de seguridad.



Este símbolo indica la existencia de un peligro potencial que puede causar lesiones graves o la muerte. Después del mismo se incluye información de seguridad importante.



Este símbolo indica la existencia de un peligro potencial para usted o para el equipo. Después del mismo se incluye información importante que indica la forma de evitar daños al equipo o la forma de prevenir lesiones menores.

NOTA: Los avisos contienen información importante, présteles especial atención.



PELIGRO: Lesión por inyección - La corriente de pintura a alta presión que produce este equipo puede perforar la piel y tejidos subyacentes, lo que conduciría a lesiones graves y a una posible amputación. Consulte de inmediato a un médico.

¡NO TRATE LAS LESIONES POR INYECCIÓN COMO SI FUERAN SIMPLES CORTES! Una inyección puede conducir a una amputación. Consulte de inmediato a un médico.

El rango de operación máximo de la unidad es 3300 PSI / 22.8 MPa de presión de fluidos.

PARA PREVENIR:

- NO dirija NUNCA la pistola a ninguna parte del cuerpo.
- NO permita NUNCA que ninguna parte del cuerpo tenga contacto con la corriente de fluido. EVITE tener contacto con corrientes de fluido que salgan de fugas que haya en la manguera.
- NO ponga NUNCA la mano delante de la pistola. Los guantes no ofrecen ninguna protección contra una lesión por inyección.
- Ponga SIEMPRE el seguro del gatillo de la pistola, cierre la bomba y libere toda la presión antes de realizar labores de mantenimiento y reparación, limpiar la boquilla o el protector, cambiar la boquilla o dejar de usarla. La presión no se descargará apagando el motor. La válvula PRIME/SPRAY (cebar/pulverizar) o válvula de purga de presión debe estar en la posición adecuada para liberar la presión del sistema. Consulte el PROCEDIMIENTO PARA LIBERAR PRESIÓN descrito en el presente manual.
- Mantenga puesto SIEMPRE el protector de la boquilla mientras atomice. El protector de la boquilla ofrece cierta protección contra lesiones por inyección, pero es principalmente un dispositivo de advertencia.
- Quite SIEMPRE la boquilla del atomizador antes de enjuagar o limpiar el sistema.
- Pueden desarrollarse fugas en la manguera de pintura por causa del desgaste, retorcimientos o el abuso. Una fuga es capaz de inyectar el material en la piel. Cada vez que use la manguera de pintura, inspecciónela antes.
- NO use NUNCA una pistola de atomización que no tenga un protector o un bloqueador o un protector de gatillo puesto y que funcione.
- Todos los accesorios deben cumplir o superar las especificaciones nominales para la gama de presiones de funcionamiento del pulverizador. Esto incluye boquillas pulverizadoras, pistolas, extensiones y manguera.

NOTA PARA EL MÉDICO:

La inyección dentro de la piel es una lesión traumática. Es importante que la lesión se trate quirúrgicamente tan pronto como sea posible. NO retrase el tratamiento por investigar la toxicidad. La toxicidad es motivo de preocupación con algunos revestimientos que se inyectan directamente en la corriente sanguínea. Es recomendable consultar a un cirujano plástico o reconstructor de manos.

PELIGRO: EXPLOSIÓN O INCENDIO – Los vapores de solventes y pinturas pueden explotar o incendiarse. Se pueden producir lesiones graves y daños materiales.

PARA PREVENIR:

- Debe proveerse un escape y aire fresco para hacer que el aire que está dentro del área de atomización se mantenga libre de acumulaciones de vapores inflamables.
- Evite todas las fuentes de ignición como son las chispas electrostáticas, llamas abiertas, llamas de piloto y objetos calientes. La conexión o desconexión de cables eléctricos o pulsar interruptores de luz pueden generar chispas.
- No fume en la zona de trabajo.
- Debe haber un equipo para la extinción de incendios permanentemente y en buenas condiciones.
- Coloque la bomba para pintar en una zona bien ventilada. Los vapores inflamables son a menudo más pesados que el aire. La zona del piso debe estar extremadamente bien ventilada. La bomba para pintar contiene piezas que forman arcos eléctricos que emiten chispas y pueden encender los gases.
- El equipo y los objetos que estén dentro y alrededor del área de atomización deben conectarse a tierra de manera adecuada para prevenir las descargas eléctricas y las chispas.
- Use solamente mangueras para fluidos de alta presión conductoras o conectadas a tierra. La pistola debe estar conectada a tierra mediante las conexiones de la manguera.
- El cable de alimentación debe enchufarse a un circuito con conexión de tierra (solamente los modelos eléctricos).
- Siempre enjuague la unidad en un recipiente de metal independiente, con presión baja en la bomba y sin la boquilla. Sostenga la pistola firmemente contra el recipiente para ponerlo a tierra y evitar chispas estáticas.
- Siga las advertencias y avisos de seguridad del fabricante de los materiales y el disolvente.
- Tenga extremado cuidado cuando utilice materiales cuyo punto de ignición sea inferior a 21° C (70° F). El punto de ignición es la temperatura a la cual pueden encenderse los vapores emanados por un fluido.
- El plástico puede causar chispas estáticas. Nunca utilice plásticos colgados para cerrar un área de atomización. No utilice plástico para proteger el piso cuando pinte materiales inflamables.
- Utilice la presión más baja posible para enjuagar el equipo.

MOTOR DE GASOLINA (SEGÚN CORRESPONDA)

Coloque siempre la bomba fuera del edificio, al aire libre. Mantenga todo disolvente alejado del escape del motor. Nunca llene el tanque de combustible con el motor en marcha o caliente. La superficie caliente puede encender el combustible derramado. Conecte siempre un conductor desde la unidad de la bomba a un objeto puesto a tierra, por ejemplo, una tubería de agua metálica. Consulte el manual del motor para obtener información completa de seguridad.

PELIGRO: PELIGRO DE EXPLOSIÓN DEBIDO A MATERIALES INCOMPATIBLES – Podría causar lesiones graves o daños materiales.

PARA PREVENIR:

- No utilice materiales que contengan lejía o cloro.
- No use disolventes con hidrocarburos hidrogenados, tales como productos para eliminar el moho, cloruro de metileno y 1, 1, 1 – tricloroetano. Estos no son compatibles con el aluminio.
- Póngase en contacto con el proveedor del producto para obtener información de compatibilidad con el aluminio.

PELIGRO: GASES PELIGROSOS - Las pinturas, disolventes, insecticidas y otros materiales pueden ser perjudiciales si se inhalan o entran en contacto con el cuerpo. Los gases pueden causar náuseas, desmayos o envenenamientos graves.

PARA PREVENIR:

- Use una mascarilla respiratoria o máscara siempre que exista la posibilidad de que se puedan inhalar vapores. Lea todas las instrucciones incluidas con la máscara para estar seguro de que se tendrá la protección necesaria contra la inhalación de vapores dañinos.
- Use gafas protectoras.
- Use ropa de protección, según lo requiera el fabricante del producto.

PELIGRO: GENERAL – Este producto puede causar graves lesiones o daños materiales.

PARA PREVENIR:

- Lea todas las instrucciones y advertencias antes de hacer funcionar el equipo.
- Desconecte siempre el motor de suministro eléctrico antes de dar servicio al equipo (sólo modelos eléctricos).
- Observe todos los códigos locales, estatales y nacionales apropiados que rigen las medidas de ventilación la prevención de incendios y el funcionamiento.
- Los Estándares de Seguridad del Gobierno de los Estados Unidos se han adoptado bajo el Acta de Seguridad y Salud Ocupacionales (OSHA por sus siglas en inglés). Deben consultarse estos estándares, particularmente la parte 1910 de los Estándares Generales y la parte 1926 de los Estándares de la Construcción.
- Utilice únicamente piezas autorizadas por el fabricante. El usuario asume todos los riesgos y responsabilidades si usa piezas que no cumplen con las especificaciones mínimas y dispositivos de seguridad del fabricante de la bomba.
- Antes de usarla cada vez, revise todas las mangueras en busca de cortes, fugas, una cubierta desgastada por abrasión o con abolladuras. Compruebe que no existan daños en las uniones ni que se hayan movido. Si existiera cualquiera de estas condiciones, reemplace la manguera inmediatamente. No repare nunca una manguera de pintura. Reemplácela por otra manguera de alta presión conectada a tierra.
- No atomice en días con viento.
- Use ropa que evite el contacto de la pintura con la piel y el cabello.

Instrucciones para conectar a tierra

Los modelos eléctricos deben ser conectados a tierra. En caso de que ocurra un cortocircuito, la conexión a tierra reduce el riesgo de descarga eléctrica al proporcionar un hilo de escape para la corriente eléctrica. Este producto está equipado con un cable que tiene un hilo de conexión a tierra con un enchufe de conexión a tierra adecuado. El enchufe debe ser conectado a una toma que esté debidamente instalada y conectada a tierra, de acuerdo con todos los códigos y ordenanzas locales.

PELIGRO – Una instalación inapropiada del enchufe de conexión a tierra puede dar como resultado el que exista un riesgo de descarga eléctrica. Si es necesario reparar o reemplazar el cable o el enchufe, no conecte el hilo de conexión a tierra a ninguno de los terminales de hoja planos. El hilo con aislamiento que tiene la superficie exterior de color verde con franjas amarillas o sin ellas es el hilo de conexión a tierra que debe conectarse al terminal de conexión a tierra.

Verifique con un electricista o técnico de servicio cualificado si las instrucciones para realizar la conexión a tierra no le han quedado suficientemente claras, o si duda que el producto haya quedado conectado a tierra de manera adecuada. No modifique el enchufe que se proporciona. Si el enchufe no entra en la toma de corriente, pida a un electricista cualificado que instale la toma apropiada.

Este producto tiene una calificación de más de 15 amperios y debe utilizarse en un circuito que tenga una calificación nominal de 120 voltios, o el producto debe utilizarse en un circuito que tenga una calificación nominal de más de 120mvoltios, y está equipado en fábrica con un cable eléctrico y un enchufe específicos para permitir su conexión a un circuito eléctrico adecuado. Asegúrese de que el producto sea conectado a una toma que tenga la misma configuración que el enchufe. Con este producto no se debe utilizar ningún adaptador. Si el producto tiene que volverse a conectar para su uso en un circuito eléctrico de otro tipo, la reconexión debe ser realizada por personal de servicio cualificado.

⚠ PRECAUCION

Utilice únicamente un cable de extensión de tres hilos que tenga un enchufe de conexión a tierra de 3 hojas y un receptáculo de tres ranuras que acepte el enchufe del producto. Asegúrese de que su cable de extensión esté en buen estado. Cuando utilice un cable de extensión, asegúrese de utilizar uno lo suficientemente fuerte como para transportar toda la corriente que va a necesitar su producto. Un cable menor originará una caída en la tensión de la línea, dando como resultado una pérdida de energía y un sobrecalentamiento. Para longitudes menores de 15 metros, deben utilizarse cables de extensión del calibre 12 AWG. Si se va a utilizar un cable de extensión en el exterior, debe estar marcado con el sufijo A-W después de la designación del tipo de cable. Por ejemplo, SJTW-A para indicar que el cable es apropiado para su uso en exteriores.

Seguridad del motor de gasolina

⚠ ADVERTENCIA

El escape del motor de esta unidad contiene productos químicos que el Estado de California reconoce que causan cáncer, defectos congénitos u otros daños a la reproducción.

1. Los motores Honda han sido diseñados para ofrecer un servicio seguro y fiable, si son manejados de acuerdo con las instrucciones. Lea y comprenda el Manual del Propietario de Honda antes de hacer funcionar el motor. Si no hace esto, podrían producirse lesiones personales o daños en el equipo.
2. Para evitar riesgos de incendio y proporcionar una ventilación adecuada, mantenga el motor como mínimo a 1 metro (tres pies) de edificios y de otros equipos durante su funcionamiento. No coloque objetos inflamables cerca del motor.
3. Los niños y los animales de compañía deben mantenerse alejados del área de trabajo, debido a la posibilidad de quemaduras producidas por los componentes calientes del motor o de daños producidos por el equipo al que haga funcionar el motor.
4. Conozca el modo de detener rápidamente el motor, y entienda el funcionamiento de todos los controles. No permita que nadie haga funcionar el motor sin las instrucciones adecuadas.
5. La gasolina es extremadamente inflamable y es explosiva en determinadas circunstancias.
6. Reabastézcase de combustible en una zona bien ventilada y con el motor apagado. No fume ni permita que haya llamas ni chispas en el área de reabastecimiento de combustible ni donde se almacene la gasolina.
7. No llene excesivamente el tanque de combustible. Tras repostar, asegúrese de que la tapa del tanque está adecuadamente cerrada y asegurada.
8. Tenga cuidado de no derramar combustible cuando realice el reabastecimiento. Los vapores del combustible o el combustible derramado pueden inflamarse. Si se derrama combustible, asegúrese de que el área esté seca antes de arrancar el motor.
9. Nunca haga funcionar el motor en un área cerrada o reducida. Los gases de escape contienen monóxido de carbono tóxico: su exposición puede causar la pérdida del conocimiento y puede originar la muerte.
10. El silenciador se calienta mucho durante el funcionamiento y permanece caliente durante un tiempo después de que el motor esté parado. Tenga cuidado de no tocar el silenciador mientras está caliente. Para evitar quemaduras graves o riesgos de incendio, deje que el motor se enfríe antes de transportarlo o almacenarlo en el interior.
11. Nunca transporte una unidad con gasolina en el tanque.

⚠ ADVERTENCIA

NO utilice este equipo para atomizar agua o ácido.

⚠ PRECAUCION

No levante el equipo por el mango del carro cuando realice su carga o descarga.

Parts Lists and Service Instructions

Main Assembly

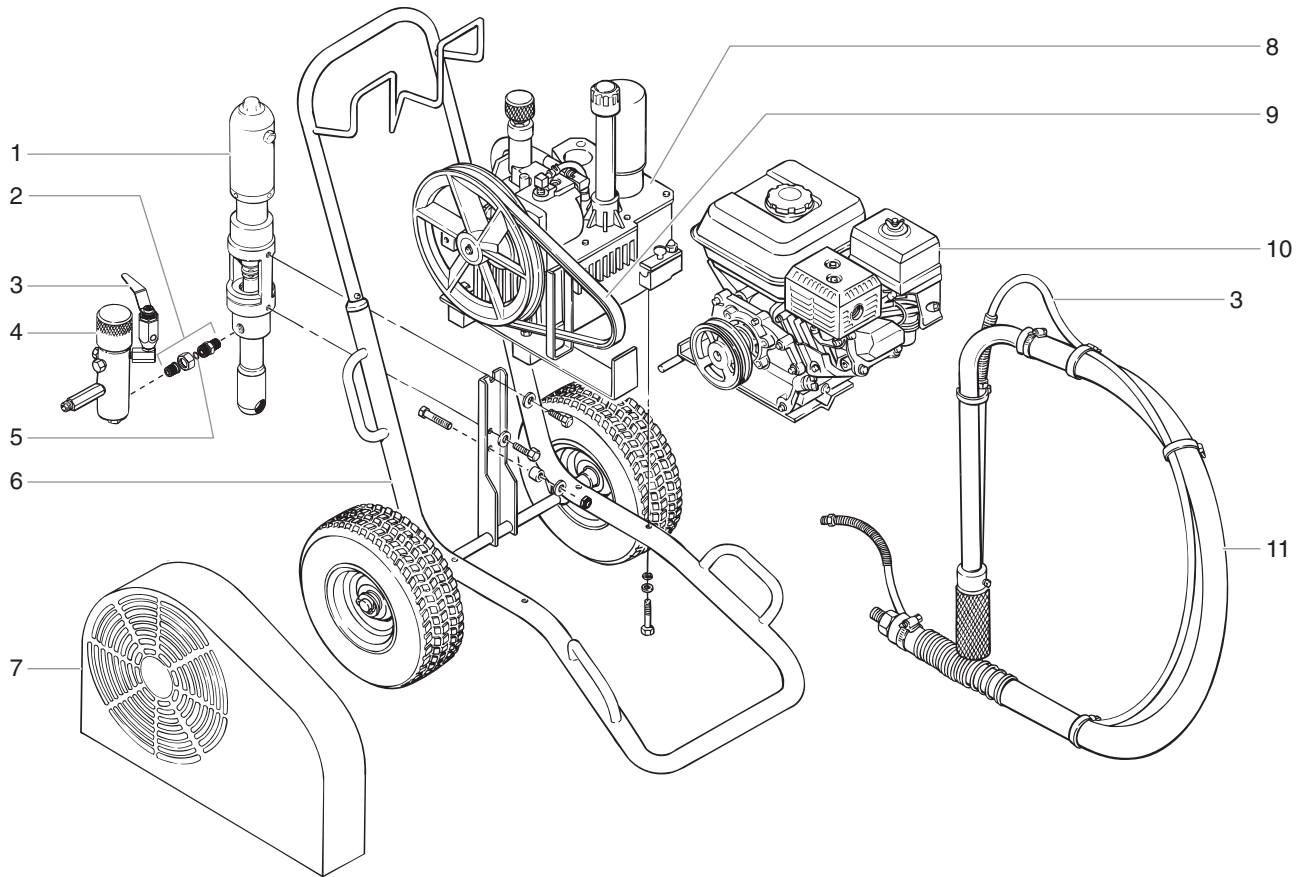

Item	Part #	Description	Quantity
1	236-154	Motor/pump assembly	1
2	703-137	Swivel fitting assembly (includes item 5) .	1
3	-----	Bleed hose assembly w/valve	1
4	930-514	Filter assembly	1
5	703-136	O-ring	1
6	449-927	Cart assembly	1
7	449-934	Belt guard assembly.....	1

Item	Part #	Description	Quantity
8	-----	Hydraulic system	1
9	449-986	Belt, "V"	1
10	506-277	Convertokit, 9 HP, Honda, gasoline (gas model)	1
11	103-830	Siphon hose assembly, 1" x 4.5'	1
12	506-207	Convertokit, DC electric, 115V (electric model, not shown)	1

Bleed Hose Assembly with Valve

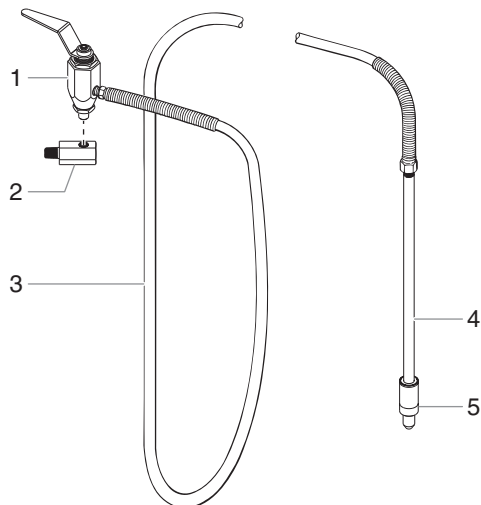

Item	Part #	Description	Quantity
1	944-030	Bleed valve.....	1
2	944-014	Elbow, 90°	1
3	500-515	Hose assembly.....	1
4	103-300	Bleed tube (includes item 5)	1
5	103-118	Diffuser	1
	335-590	Bleed line assembly (includes items 3-5)	
	191-211	Bushing, 1/4" male x 1/8" female (For use with older hose assemblies that have 1/8" NPT thread — allows the attachment of the older hose to bleed valve P/N 944-030.)	
	944-040	Bleed valve kit (includes items 1, 2, 4 and bushing P/N 191-211)	

Cart Assembly (P/N 449-927)

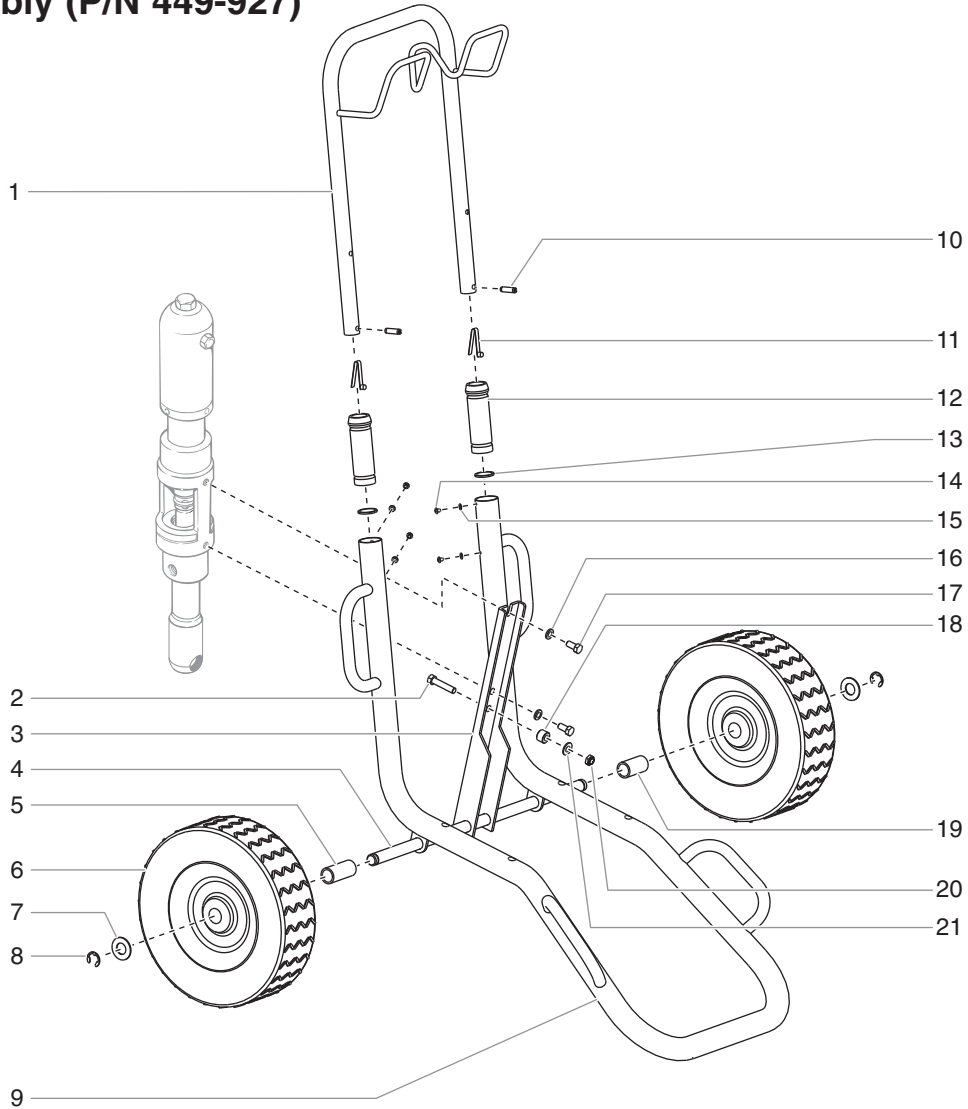

Item	Part #	Description	Quantity
1	590-502	Handle	1
2	862-460	Screw	1
3	459-051	Motor/pump bracket	1
4	590-503	Axle	1
5	449-120	Spacer (long)	1
6	670-109	Wheel	2
7	870-004	Washer	2
8	590-100	Retaining ring	2
9	449-060	Frame	1
10	590-508	Roll pin	2
11	590-507	Snap button	2

Item	Part #	Description	Quantity
12	590-504	Sleeve	2
13	590-506	Washer	2
14	856-921	Screw	4
15	856-002	Washer	4
16	862-002	Lock washer	2
17	862-428	Screw	2
18	449-052	Spacer	1
19	449-145	Spacer (short)	1
20	862-411	Nut	1
21	862-001	Flat washer	1

Belt Guard Assembly (P/N 449-934)

Item	Part #	Description	Quantity
1	449-217	Belt guard	1
2	858-636	Screw	2
3	858-002	Lockwasher	2
4	862-411	Nut	1
5	449-185	Belleville washer	1
6	862-001	Flat washer	1
7	449-187	Clip	1
8	449-198	Flat washer	1
9	449-166	Bolt	1
	313-2492	Label (not shown)	

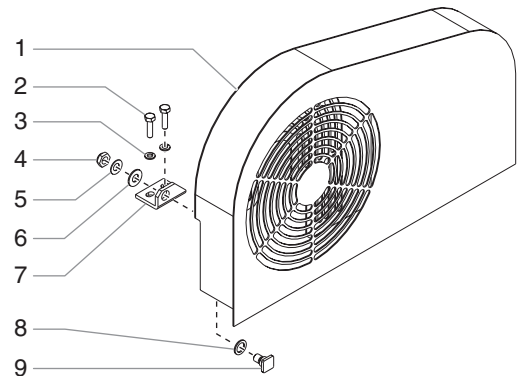

DC — Electric Convertokit (P/N 506-207)

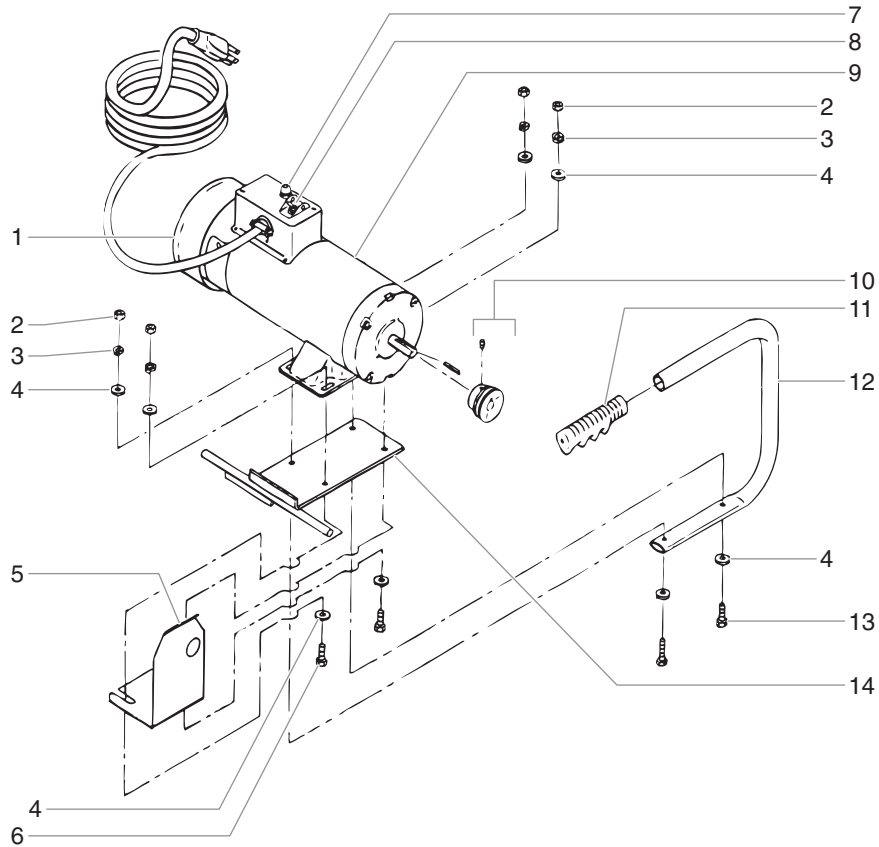

<u>Item</u>	<u>Part #</u>	<u>Description</u>	<u>Quantity</u>	<u>Item</u>	<u>Part #</u>	<u>Description</u>	<u>Quantity</u>
1	506-259	Cover.....	1	10	977-228	Pulley.....	1
2	860-501	Nut stop.....	4	11	590-068	Handle grip.....	1
3	860-002	Lock washer.....	4	12	335-017	Handle.....	1
4	860-004	Flat washer.....	8	13	860-552	Screw.....	2
5	459-016	Motor shaft shield.....	1	14	459-005	Mount plate.....	1
6	860-535	Screw.....	2	15	506-255	Rectifier (not shown).....	1
7	506-257	Circuit breaker reset.....	1	16	506-258	Fan (not shown).....	1
8	506-260	ON/OFF switch.....	1	17	449-986	Belt, "V" (not shown, not part of assembly)	
9	978-350	Motor, DC-Electric, 2 HP, 50 / 60 Hz, 115 V.....	1				

Gas Convertokit (P/N 506-277)

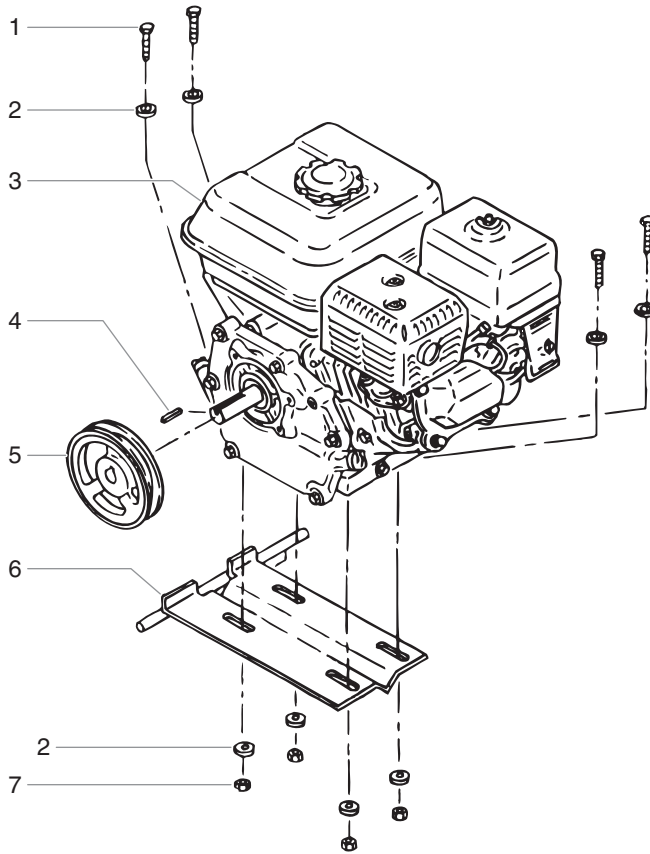

Item	Part #	Description	Quantity
1	860-460	Screw	4
2	862-001	Flat washer.....	8
3	764-021	Engine, gas 9 HP, Honda.....	1
4	980-307	Key	1
5	459-008	Pulley.....	1
6	459-003	Mounting plate, gas engine.....	1
7	862-410	Stop nut.....	4
8	449-986	Belt, "V" (not shown, not part of assembly)	

Siphon Hose Assembly

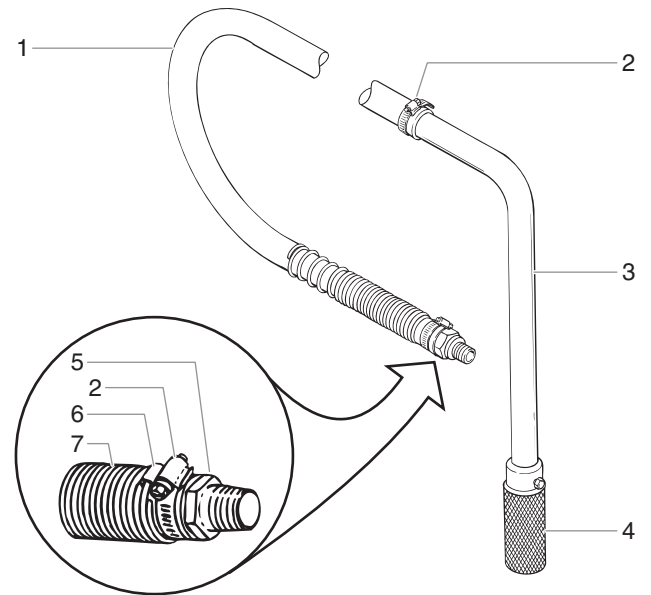

Item	Part #	Description	103-830 Qty.	103-808 Qty.
1	420-070	Hose.....	4.5'	6.5'
2	103-679	Hose clamp	2	2
3	103-575	Tube.....	1	
	103-585	Tube.....		1
4	103-627	Rock catcher	1	1
5	194-771	Adapter	1	1
6	103-119	Clip.....	1	1
7	103-125	Spring.....	1	1

Bleed Valve Assembly (P/N 944-030)

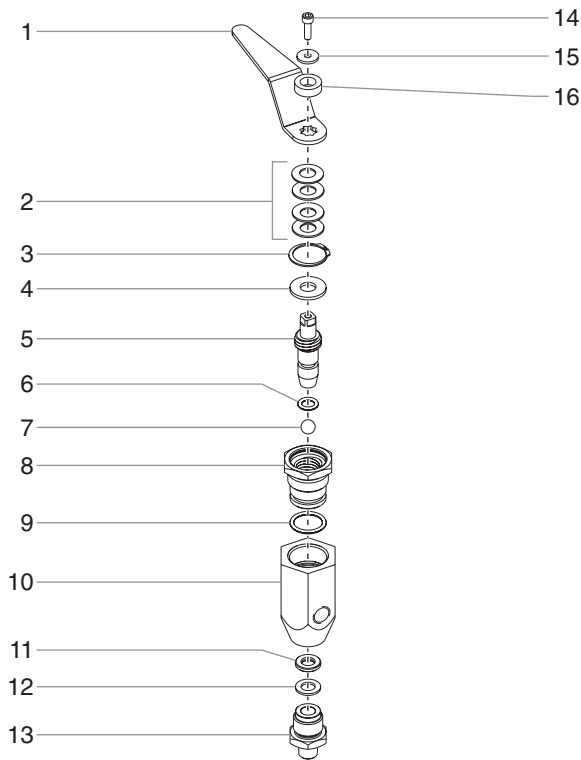

Item	Part #	Description	Quantity
1	944-034	Valve handle.....	1
2	944-035	Bellville washer.....	4
3	944-036	Retaining ring.....	1
4	944-037	Valve washer.....	1
5	944-011	Valve stem.....	1
6	944-038	Stem o-ring.....	1
7	944-039	Ball.....	1
8	944-012	Valve body.....	1
9	944-042	Valve o-ring.....	1
10	944-010	Valve housing.....	1
11	944-043	Valve seat.....	1
12	944-044	Valve seal.....	1
13	944-013	Valve seat retainer.....	1
14	944-047	Hex screw.....	1
15	944-029	Flat washer.....	1
16	944-046	Spacer.....	1
	944-000	Valve seal kit (includes items 6, 7, 9, and 12)	

Filter Assembly

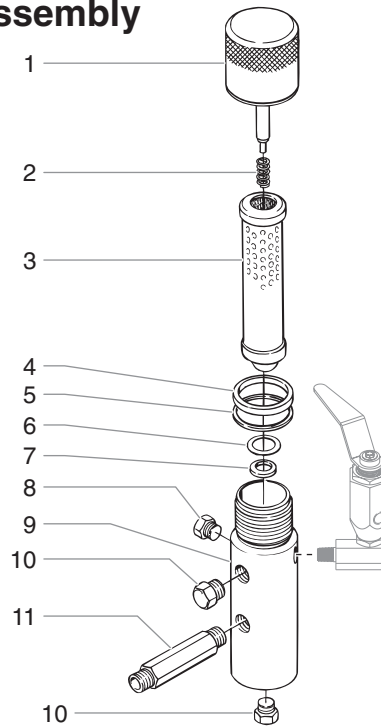

Item	Part #	Description	930-514 Qty.	930-515 Qty.	930-516 Qty.
1	930-937	Filter cap assembly.....	1	1	1
2	930-020	Spring.....	1	1	1
3	930-005	Filter element, 5 M, w/ball.....	1		
	930-006	Filter element, 50 M, w/ball.....		1	
	930-007	Filter element, 100 M, w/ball.....			1
4	920-006	Gasket, UVØ (thick).....	1	1	1
5	920-070	Gasket, UVØ (thin).....	1	1	1
6	891-193	O-ring, UVØ.....	1	1	1
7	180-909	Seat, tungsten carbide.....	1	1	1
8	227-027	Pipe plug.....	1	1	1
9	930-920	Filter body.....	1	1	1
10	227-033	Pipe plug.....	2	2	2
11	191-324	Hex fitting, 1/4" (installed).....	1	1	1
	808-550	Hex fitting, 3/8" (included in Lit. Set).....	1	1	1

Filter Service Kit (P/N 930-050)

Item	Part #	Description	Quantity
2	930-020	Spring.....	1
4	920-006	Gasket, UVØ.....	1
5	920-070	Gasket, UVØ.....	1
6	891-193	O-Ring, UVØ.....	1

Specifications

Maximum Working Pressure.....	5000 psi (34.5 MPa)
Filter Area.....	18 In ² (116 cm ²)
Outlet Ports.....	(1) 1/4" NPT(F) for bleed valve (1) 3/8" NPT(F) with 1/4 NPSM(M) hose connection (1) 3/8" NPT(F) plugged for additional gun hookup.
Wetted Parts.....	Carbon steel with electroless nickel and cadmium plating, stainless steel, tungsten carbide, UVØ

Hydraulic System

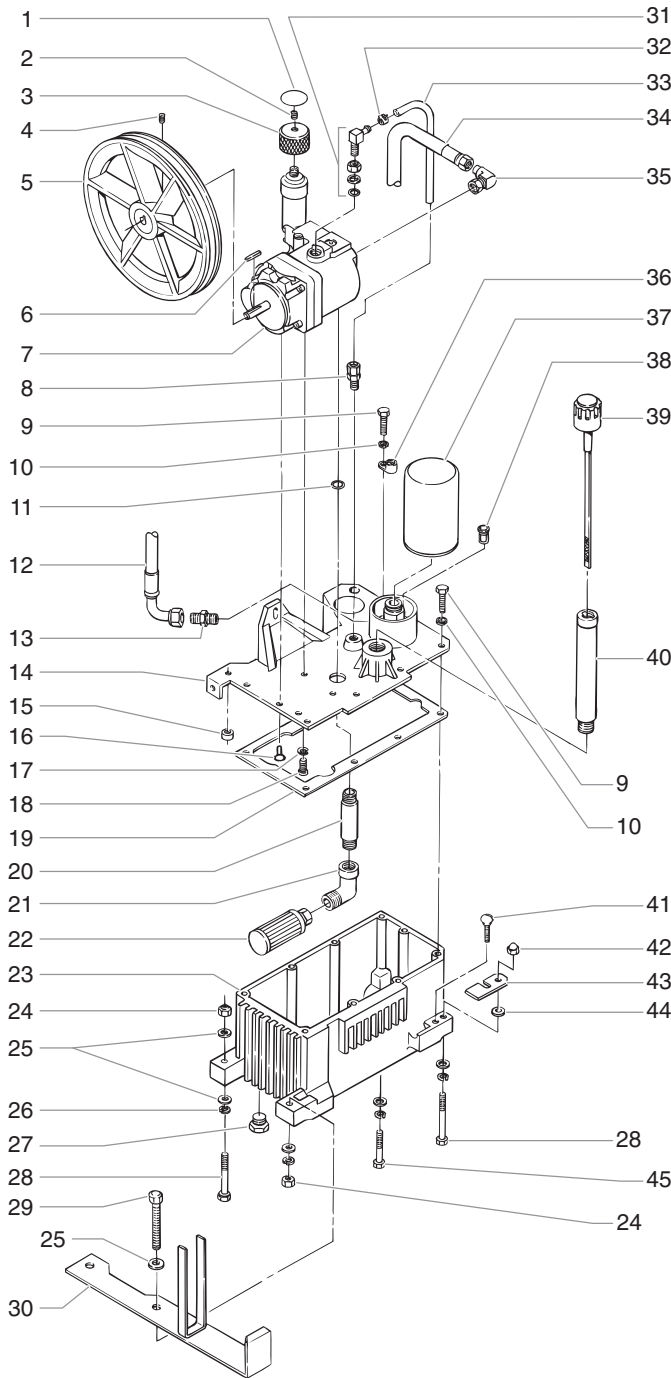

Item	Part #	Description	Quantity
1	313-755	Knob decal	1
2	862-414	Set screw	1
3	448-243	Pressure control knob	1
4	860-520	Set screw	1
5	449-195	Pulley/fan assembly	1
6	448-494	Key, pump (.156 x .156 x 1 ^{3/16})	1
7	449-752	Hydraulic pump	1
8	431-042	Tube connector	1
9	858-636	Screw, HH	8
10	858-002	Lock washer	10
11	325-031	O-ring	1
12	448-231	Return hose assembly	1
13	451-029	Fitting	1
14	449-616	Tank cover	1
15	858-609	Clinch nut	1
16	858-621	Socket screw	2
17	859-001	Washer	2
18	858-624	Screw	2
19	449-605	Tank gasket	1
20	112-208	Nipple	1
21	472-500	Elbow, street	1
22	448-208	Inlet screen	1
23	449-623	Hydraulic tank	1
24	862-411	Flex lock nut	2
25	862-001	Flat washer	6
26	862-002	Lock washer	4
27	449-212	Plug	1
28	862-493	Screw, HH	2
29	862-496	Tap bolt	1
30	449-982	Shield	1
31	192-228	Elbow	1
32	449-126	Hose clamp	1
33	420-250	Tubing, UVØ	1
34	448-246	Pressure hose assembly	1
35	192-051	Elbow	1
36	101-205	Ground lug	1
37	451-220	Hydraulic filter	1
38	449-609	Hydraulic by-pass	1
39	449-626	Hydraulic fluid cap/dipstick	1
40	449-614	Tube assembly	1
41	862-438	Thumb screw	1
42	862-402	Acorn nut	1
43	449-107	Mounting plate retainer	1
44	449-135	Spacer	1
45	862-480	Screw, HH	1
46	451-121	Elbow (not shown)	1
47	941-555	Ball valve (not shown)	1

Torque and Sealant Guide

Item	Description
4	Use blue Loctite on threads
4	Torque to 10 ft./lbs. (13.5 N/m)
8	Use hydraulic sealant
13	Use hydraulic sealant
16	Use blue Loctite on threads
16	Torque to 8 FT/LBS (11 N/m)
18	Torque to 8 FT/LBS (11 N/m)
20	Use hydraulic sealant
21	Use hydraulic sealant
22	Use hydraulic sealant
28	Torque to 15 FT/LBS (20,5 N/m)
29	Torque to 15 FT/LBS (20,5 N/m)
37	Torque to 20 FT/LBS (28 N/m)
45	Torque to 15 FT/LBS (20,5 N/m)

Hydraulic Motor

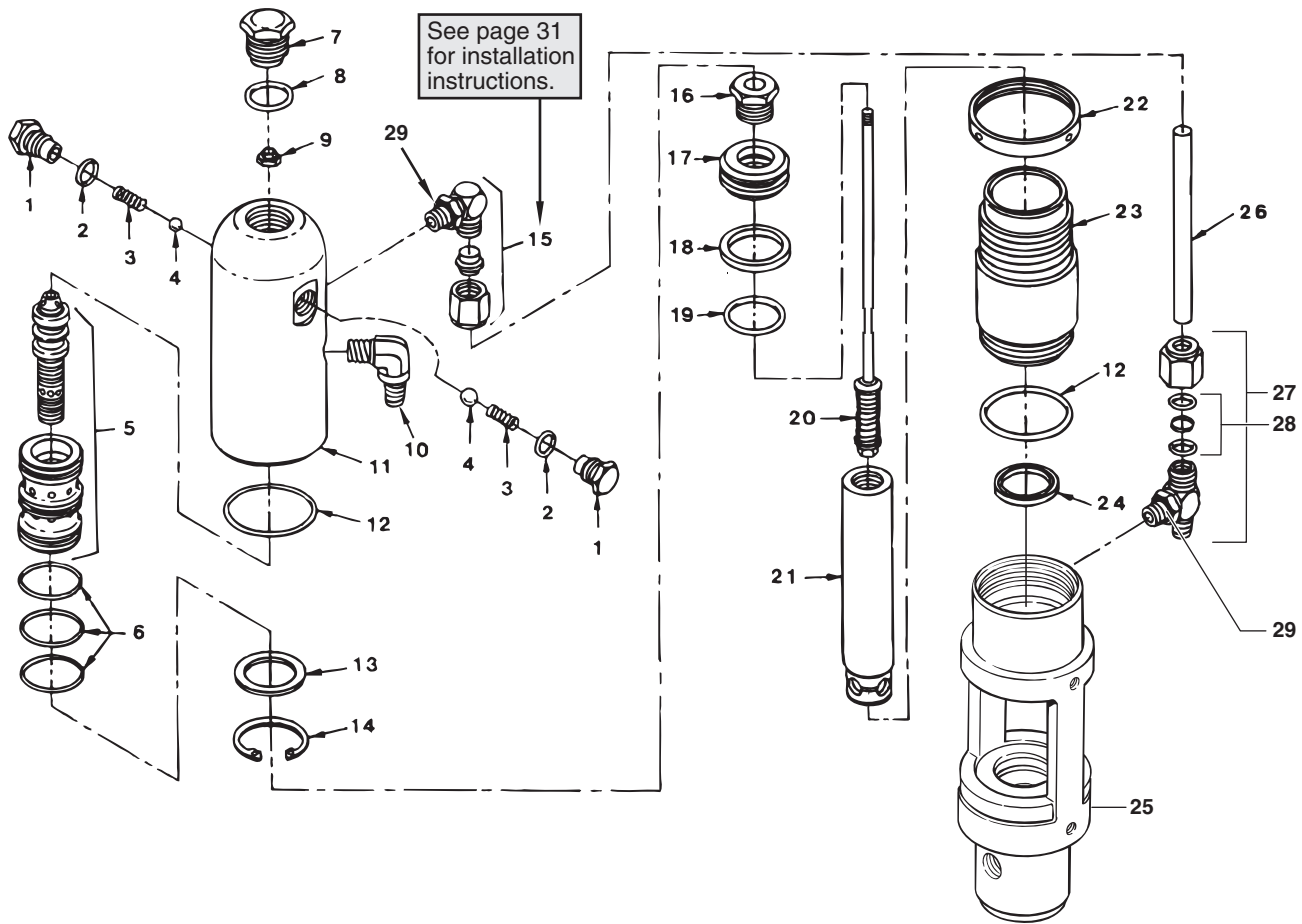

Item	Part #	Description	Quantity
1	235-018	Trip retainer.....	2
2	141-007	O-ring.....	2
3	325-005	Trip spring,.....	2
4	569-016	Ball, SS.....	2
5	441-908	Spool / sleeve set.....	1
6	441-152	O-ring.....	3
7	235-030	Cylinder head plug.....	1
8	441-217	O-ring.....	1
9	858-811	Flex lock nut.....	1
10	451-121	Elbow, 90°.....	1
11	235-112	Cylinder head.....	1
12	431-032	O-ring.....	2
13	431-053	Sleeve retainer.....	1
14	431-054	Retainer ring.....	1
15	192-000	Elbow.....	1
16	235-022	Piston retainer screw.....	1
17	235-014	Piston.....	1
18	235-027	Piston seal.....	1
19	235-026	O-ring.....	1
20	236-021	Valve rod assembly.....	1
21	236-948	Piston rod.....	1
22	235-001	Lock ring.....	1
23	236-007	Cylinder.....	1
24	235-028	Rod seal.....	1
25	236-829	Motor/pump block.....	1
26	236-029	Motor tube.....	1
27	235-125	Tee.....	1
28	431-019	O-ring kit.....	1
29	700-499	O-ring.....	2
235-050		Motor service kit, minor (includes items 2-4, 6, 8, 9, 12, 18, 19, and 24)	

Servicing the Hydraulic Motor

Perform this procedure using the necessary parts from Motor Service Kit — Minor (P/N 235-050). If the hydraulic motor is operable, start the machine and jog the piston rod (21) into its top position.

NOTE: Servicing of the hydraulic motor should be carried out in a clean, dust free area only. Any dust or metallic particles left in the motor or entering it on reassembly may damage the critical parts and affect its service life and warranty. All parts should be inspected for absolute cleanliness.

Disassembling the Hydraulic Motor

1. Disconnect the pressure hose from the elbow (34 and 35 in Hydraulic System parts list) on the back of the hydraulic pump.
2. Remove the two mounting screws and two lock washers (17 and 16 in Cart Assembly parts list) that attach the motor/pump assembly to the cart.
3. Place the motor/pump assembly in a vise, holding it securely by the motor/pump block (25).
4. Remove cylinder head plug (7).
5. Loosen lock ring (22) with a spanner wrench and unthread tube retaining nut on tee (27). Loosen tube retaining nut on elbow (15). Slide the nut down. Push motor tube (26) into tee (27) far enough to clear elbow (15). Slowly unthread cylinder head (11) and lift it just high enough above the cylinder (23) to reach the valve rod assembly (20) with vise grip pliers.
6. The piston rod (21) should be near the top of its stroke for disassembly. It may be necessary to use a wood or nylon driver to push the piston rod up to its top position.

7. Grip the valve rod securely with vise grip pliers and then remove the FlexLoc nut (9) from the top of the valve rod assembly (20). Be careful that spool (5) does not fall. The cylinder head (11) can now be lifted off. Unthread the cylinder (23) from the motor/pump block (25). Note: An extra lock ring (22) can be used to jam the two lock rings together on the cylinder and a pipe wrench can be used to unthread the cylinder (23) from the motor/pump block (25).

8. To remove the connecting pin, slide the retaining ring down with a small screwdriver, and then push the connecting pin out.

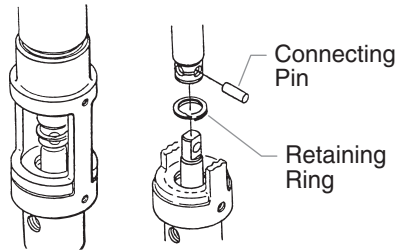

9. Remove the piston rod assembly from the motor/pump block (25).

10. Remove rod seal (24), being extremely careful not to scratch the seal groove in the motor/pump block (25).
11. Place the piston retainer screw (16) on the piston rod assembly in a vise. Slide a long bar through the hole at the base of the piston rod for leverage, and unthread the piston rod from the piston retainer screw.
12. Remove piston (17) and lift out valve rod assembly (20).
13. Remove piston seal (18) and o-ring (19).
14. Remove trip retainers (1), trip springs (3), and balls (4) from cylinder head (11). Remove o-rings (2) from trip retainers (1).
15. Remove retaining ring (14) and sleeve retainer (13). Gently tap spool/sleeve set (5) out of cylinder head (11) using a wood or nylon rod.
16. Inspect piston rod (21) and cylinder (23) for wear, scratches, and dents. Replace if damaged.
17. Inspect spool valve (5) for wear. Replace if necessary. spool valve should move smoothly and freely with no force by holding in a vertical position. If it does not, it can cause the motor to stall.

Reassembling the Hydraulic Motor

1. Separate spool/sleeve set (5). Place o-rings (6) onto sleeve. Lubricate o-rings with hydraulic oil. Gently push the sleeve into cylinder head (11) with the flatter side of the sleeve facing out. Use a nylon rod to tap sleeve down until it reaches its full depth. Do not use any other type of tool that might damage or leave particles or residue on the sleeve. Install the spool through the top of the cylinder head, down into the sleeve.

CAUTION

Do not use Piston Lube pump packing lubricant. It is a solvent and will severely damage seals and O-Rings of the hydraulic motor.

2. Install o-rings (2) on trip retainers (1). Install trip retainer balls (4) followed by springs (3) which, when installed, will hold spool/sleeve set (5) in proper place for assembly.
3. Install sleeve retainer (13) followed by snap ring (14) into cylinder head (11), which will hold valve sleeve in place. Install o-ring (12) in the o-ring groove of the cylinder head.
4. Replace lower seal (24) in motor/pump block (25). Be sure the open portion of the seal is facing upward (V). This seal requires no special tool.
5. Place piston rod (21) in vise. Inspect valve rod assembly (20) for any damage. Make sure the lock nut at the bottom of the valve rod assembly (20) is secure. DO NOT remove. Then, place into piston rod (21) as illustrated. Install o-ring (19), lubricating it well and replacing piston (17) onto piston rod (21). Put one drop of blue Loctite on the piston retainer screw (16). Tighten piston retainer screw until piston is locked into place. Check valve rod assembly (20) for normal spring action at this time.

6. Install piston seal (18) with lips facing downward. Carefully install o-ring (19). Expand the ring and stretch it sufficiently for installation.
7. With motor/pump block (25) still in vise, install lower seal (24) by pushing it towards its groove with a properly sized blunt rod. Then complete installation with the fingers. No tool is necessary. Do not twist the seal.
8. Pre-lubricate the piston and valve rod assembly with Coolflo™ hydraulic fluid (P/N 430-361). Install piston rod (21) into motor/pump block (25) with a gently pushing and rotating motion to work the piston rod in through the seal (24).

NOTE: Inspect the bottom of piston rod (21) for nicks or sharp areas that could damage the piston seal during installation through the motor/pump block (25).

9. Replace the connecting rod pin and retainer ring.
10. Install o-ring (12) on cylinder wall. Lubricate ring and inner wall. With the piston rod held firmly, the cylinder should be gently driven over the piston seal with a rubber mallet. Tightly thread the cylinder into motor/pump block (25).
11. Raise piston rod (21) to top position and thread lock ring (22) all the way up on upper threads of cylinder (23).
12. Pull valve rod assembly (20) up as far as it will travel and grasp it with vise grip pliers. Then install cylinder head (11), already assembled, over valve rod until the top threads of the valve rod pass through the top of the spool/sleeve set (5). The valve rod threads must be clean and free of oil. Place one drop of blue Loctite on threads of flex lock nut (9) and thread nut onto valve rod to full tight position (do not over-tighten) while holding valve rod below with vise grip pliers.
13. Thread cylinder head (11) down onto the cylinder (23) and then back off just enough to reassemble hydraulic fittings and motor tube (26). Tighten lock ring with spanner wrench to hold cylinder head in position.
14. The tee assembly (27) and the elbow (15) use an o-ring (28) to seal on the outer diameter (O.D.) of the motor tube (26). The O.D. of the motor tube should be free of scratches or sharp edges. The lock nuts on these fittings first should be hand tightened, then wrench tightened another half turn.
15. Install o-ring (8) onto cylinder head plug (7). Tighten.

Hydraulic Motor Cut-Away

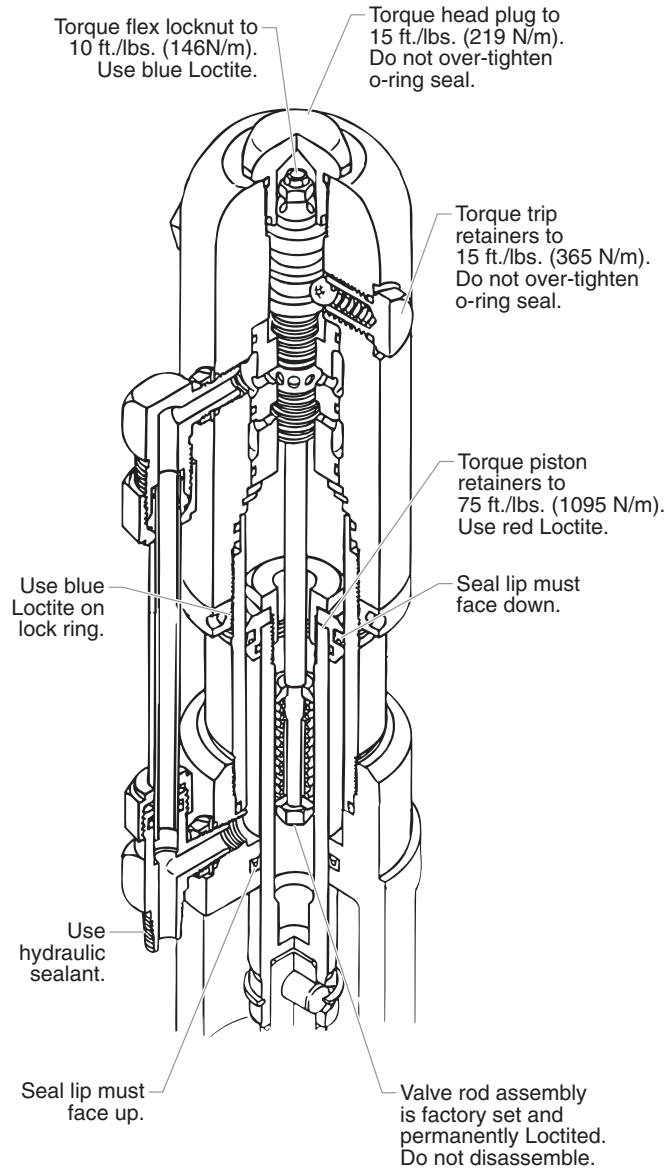

Fluid Section

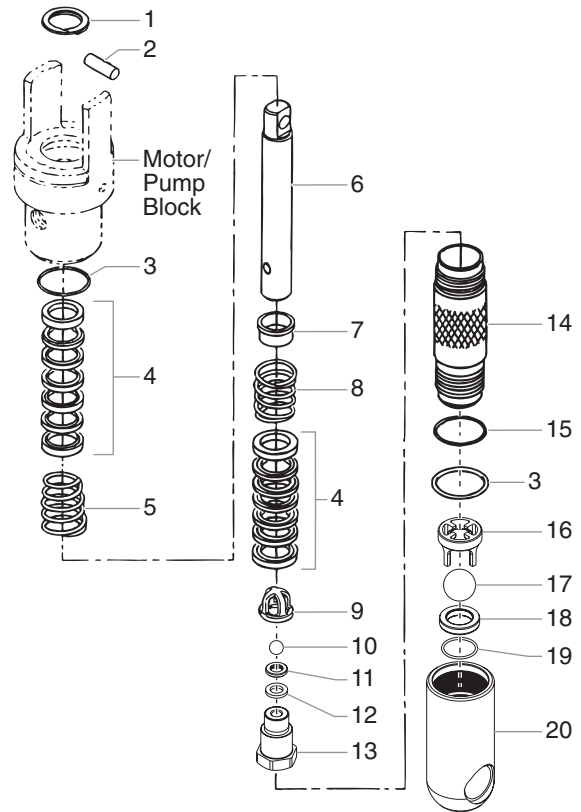

Item	Part #	Description	Quantity
1	143-019	Retaining ring	1
2	143-118	Connecting pin	1
3	145-031	O-ring, UVØØ.....	2
4	138-153	Packing set, leather/UHMWPE/steel.....	2
5	142-004	Upper packing spring	1
6	144-117	Displacement rod.....	1
7	138-001	Spring retainer.....	1
8	142-003	Lower packing spring	1
9	451-085	Outlet valve cage	1
10	138-225	Outlet valve ball.....	1
11	236-012	Outlet valve seat	1
12	236-011	Seal washer.....	1
13	236-013	Outlet valve housing.....	1
14	144-822	Pump cylinder.....	1
15	140-009	O-ring	1
16	236-141	Foot valve cage.....	1
17	178-700	Foot valve ball	1
18	143-026	Foot valve seat.....	1
19	143-025	Seat o-ring.....	1
20	236-126	Foot valve housing.....	1
	144-500	Fluid section service kit, major (includes items 6, 14, and fluid section service kit, minor P/N 144-050)	
	144-050	Fluid section service kit, minor (includes items 1, 3, 4, 10, 12, 15, 17, 19, and Loctite P/N 426-051)	
	236-010	Foot valve assembly (includes items 16–20)	
	236-050	Outlet valve assembly (includes items 9–13)	

Servicing the Fluid Section

CAUTION

Use of non-Speeflo service parts may void warranty. Ask for original parts made by Speeflo for best services. This pump should receive a routine servicing after approximately 1,000 hours of use. Earlier servicing is required if there is excessive leakage from the top packing or if pump strokes become faster on one stroke or the other. The use of Speeflo Piston Lube (P/N 314-480) is recommended as an upper packing lubricant. Do not substitute oil, water, or solvent for an upper packing lubricant.

Disassembling the Fluid Section

1. Remove the siphon hose assembly. Unthread the foot valve housing (20) and the pump cylinder (14) with a strap wrench.
2. Slide the retaining ring (1) up with a small screwdriver, then push the connecting pin (2) out.
3. Pull the displacement rod (6) through the lower cavity of the motor/pump block.
4. Remove the motor/pump block, O-ring (3), upper packing spring (5), and upper packing set (4).
5. Hold the displacement rod (6) in a vise by the flats at the top of the displacement rod and remove the outlet valve housing (13) with a wrench while holding the displacement rod horizontal with a wooden support, if necessary. Remove the seal washer (12), outlet valve seat (11), outlet valve ball (10), outlet valve cage (9), lower packing set (4), lower packing spring (8), and spring retainer (7).
6. Using a 1/2" extension bar attached to a 1/2" drive ratchet, insert the end of the extension bar into the square opening of the foot valve cage (16) inside the foot valve housing (20). Unscrew and remove the foot valve cage from the foot valve housing.
7. Remove the O-ring (3), foot valve ball (17), foot valve seat (18), and seat o-ring (19) from the foot valve housing (20).
8. Replace the connecting pin (2) and retainer ring (1) with new parts.
9. Remove the o-ring (15) from the pump cylinder (14).

Reassembling the Fluid Section

NOTE: Use DH: 9 tape on all threaded pipe connections.

1. Place a new seat o-ring (19) into the groove in the bottom of the foot valve housing (20).
2. Inspect the foot valve seat (18) for wear. If one side is worn, flip the seat to the unused side. If both sides are worn, install a new seat. Place the new or flipped seat (worn side down) into the bore at the bottom of the foot valve housing (20).
3. Place a new foot valve ball (17) onto the foot valve seat (18). Using a 1/2" extension bar attached to a 1/2" drive ratchet, insert the end of the extension bar into the square opening of the foot valve cage (16) and screw the cage into the foot valve housing (20). Torque the cage to 300 in./lbs. (25 ft./lbs.).
4. Insert a new PTFE o-ring (3) into the groove of the foot valve housing (20). Lubricate the o-ring using oil or grease.
5. After soaking the leather packings in oil (preferably linseed oil), reassemble the lower packing set (4). Place the set onto the outlet valve housing (13) with the peak of the "V" packings pointing down toward the hex on the outlet valve housing.
6. Inspect the outlet valve seat (11) for wear. If one side is worn, flip the seat to the unused side. If both sides are worn, use a new seat. Insert the outlet valve cage (9), new outlet valve ball (10), new or flipped seat (worn side away from ball), and a new seal washer (12) into the displacement rod (6).
7. Clean the threads on the outlet valve housing (13) and coat the threads with blue Loctite #242. Make sure the Loctite is only on the threads.

8. Place the lower packing spring (8) onto the outlet valve housing (13) followed by the spring retainer (7).
9. Screw the displacement rod (6) and the outlet valve housing (13) together. Tighten in a vise to 900 in./lbs. (75 ft./lbs.).
10. Insert the PTFE o-ring (3) into the upper groove of the motor/pump block.
11. Insert the upper packing set (4) into the motor/pump block with the peak of the "V" packings pointing up toward the motor.

NOTE: The packings must be soaked in oil before installation.

12. Place the upper packing spring (5) into the motor/pump block with the small tapered end facing up toward the motor/pump block.
13. Insert the displacement rod (6) up through the upper packings in the motor/pump block.
14. Align the holes in the displacement rod (6) and the hydraulic piston rod and insert the connecting pin (2).
15. Thread the short threads of the pump cylinder (14) into the motor/pump block and tighten with a strap wrench.
16. Place the o-ring (15) onto the top groove of the pump cylinder (14).
17. Thread the foot valve housing (20) onto the pump cylinder (14), tighten with a strap wrench, then back off to align the siphon hose.

NOTE: It is not necessary to over-tighten the foot valve. O-ring seals perform sealing function without excessive tightening. Full thread engagement is sufficient. The foot valve may be rotated backward up to 1/2 turn from full engagement for convenient hose position. For siphon hose attachment, it is critically important that the threads of the siphon hose fit snugly into the foot valve with the hose assembly couplings PTFE taped and sealed to prevent air leakage.

Fluid Section Cut-Away

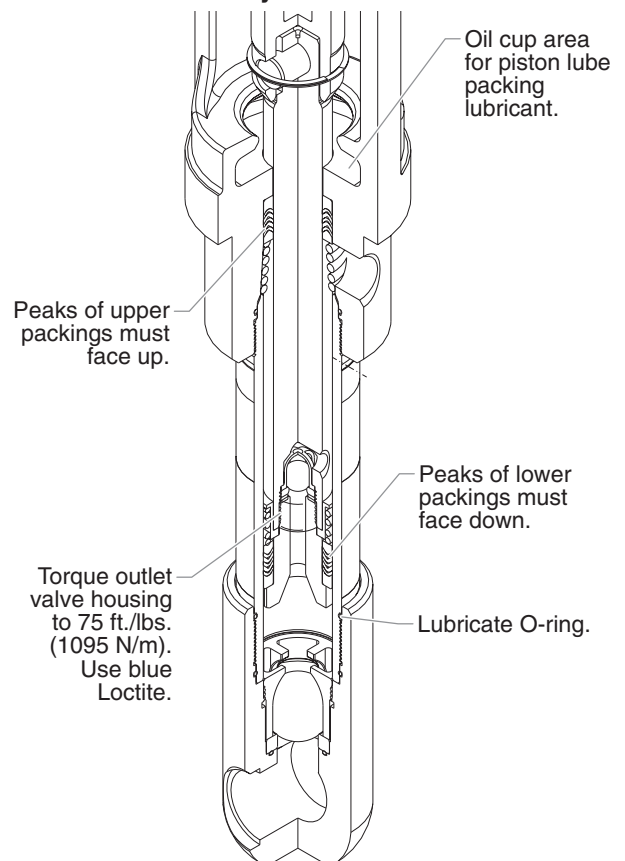

Gun Manifold Assemblies (Optional)

Single Gun Add-On Manifold Assemblies

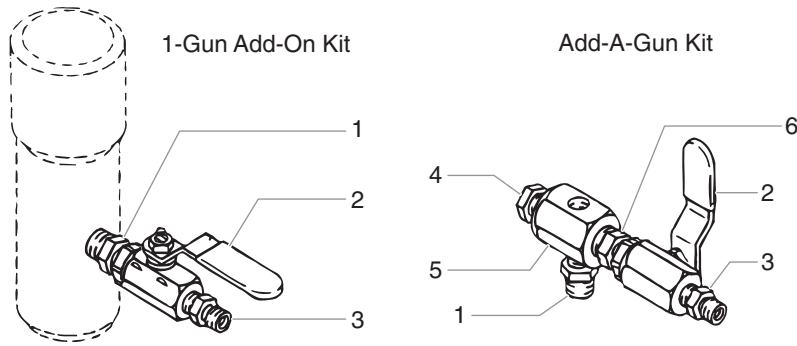

Item	Part #	Description	975-111 1 Gun Add-On 1/4"	975-311 1 Gun Add-On 3/8"	975-200 Add-A-Gun Kit 1/4"	975-300 Add-A-Gun kit 3/8"
1	814-002	Nipple, Hex	1		1	
	814-004	Nipple, Hex		1		1
2	940-553	Valve, Ball	1		1	
	941-555	Valve, Ball		1		1
3	227-006	Nipple, Hex	1		1	
	808-555	Nipple, Hex		1		1
4	227-033	Plug, Pipe			1	1
5	970-100	Block, Manifold			1	1
6	814-004	Nipple, Hex			1	1

Multiple Gun Add-On Manifold Assemblies

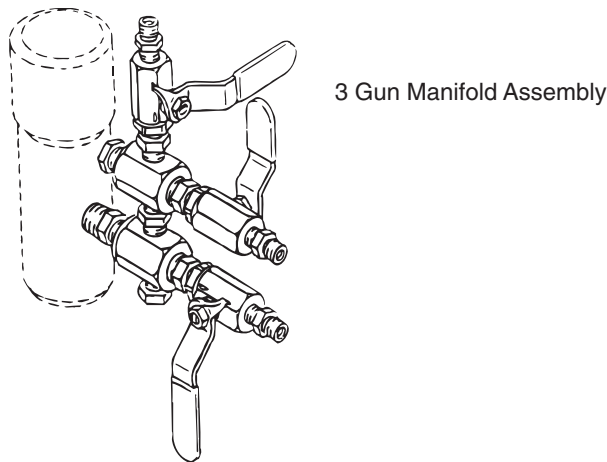

Part #	Description	975-212 2 Gun 1/4"	975-213 3 Gun 1/4"	975-214 4 Gun 1/4"	975-312 2-GUN 3/8"	975-313 3-GUN 3/8"	975-314 4-GUN 3/8"
975-111	1 Gun Add-On, 1/4"	1	1	1			
975-311	1 Gun Add-On, 3/8"				1	1	1
975-200	Add-A-Gun Kit, 1/4"	1	2	3			
975-300	Add-A-Gun Kit, 3/8"				1	2	3

SAE O-Ring Fitting Installation

Steps 1 & 2:

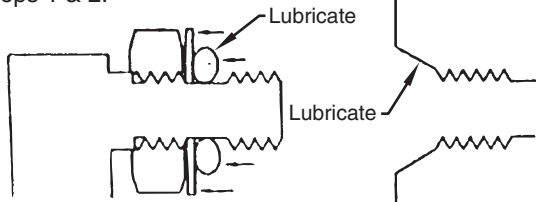

Step 3:

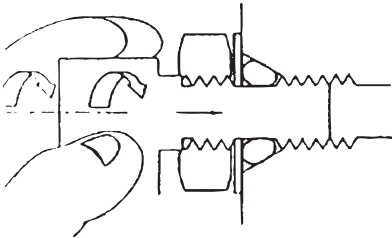

1. Pull washer and o-ring back as far as possible.
2. Lubricate o-ring and entrance port.
3. Screw fitting in until washer pushes o-ring into entrance and sits flat against port. (Do not tighten! - only do this step hand tight to compress o-ring into port!)

Step 4:

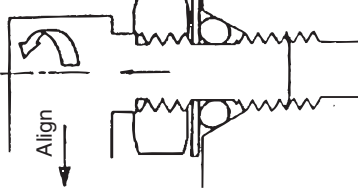

4. Back fitting out no more than one complete turn to align as required.

Step 5:

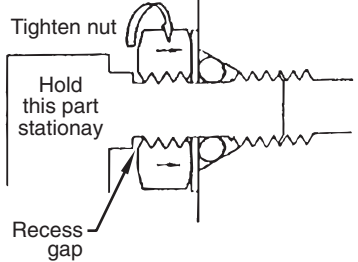

5. Torque nut wrench tight holding backup on fitting. This should expose a recess gap behind the nut which can act as an indicator that the fitting is assembled correctly. (This is a feature for a specific version of this fitting only - which screws into the cylinder head. Other fittings, as the ones which attach to the hydraulic pump, assemble the same but may not have the indicator.)

Cautions:

Avoid screwing fitting in too far.

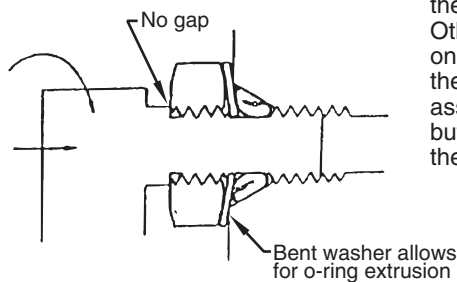

Avoid leaving fitting too far out.

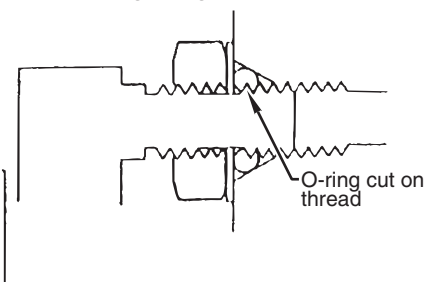

Accessories and Service Kits

These items may be purchased separately from your local Speeflo distributor.

Part #	Description
103-830	5 Gal. Siphon Hose Assembly w/Rock Catcher 1" x 4.5'
103-808	55 Gal. Siphon Hose Assembly w/Rock Catcher 1" x 6.5'
103-627	Rock Catcher
930-004	Paint Filter Element, 0 Mesh (for mastics)
930-005	Paint Filter Element, 5 Mesh (for multicolors and heavy materials)
930-006	Paint Filter Element, 50 Mesh (for latex and normal architectural materials)
930-007	Paint Filter Elements, 100 Mesh (for stains, lacquers and fine materials)
520-050	SGX-20 G, T, and 1/4" Hose Kit
520-051	SGX-20 G, T, and 3/8" Hose Kit
101-208	Grounding Clamp
101-212	Grounding Wire, 12 Gauge x 25'
314-480	Piston Lube, 8 oz.
314-482	Liquid Shield Plus, 1 quart
430-362	Coolflo™ Hydraulic Fluid, 1 quart
430-361	Coolflo™ Hydraulic Fluid, 1 gallon
975-212	2-Gun Manifold with Ball Valves, 1/4"
975-213	3-Gun Manifold with Ball Valves, 1/4"
975-312	2-Gun Manifold with Ball Valves, 3/8"
975-313	3-Gun Manifold with Ball Valves, 3/8"
808-550	3/8" NPS(M) x 3" hex fitting

Airless Tip Selection

Tips are selected by the orifice size and fan width. The proper selection is determined by the fan width required for a specific job and by the orifice size that will supply the desired amount of fluid and accomplish proper atomization.

For light viscosity fluids, smaller orifice tips generally are desired. For heavier viscosity materials, larger orifice tips are preferred. Please refer to the chart below.

NOTE: Do not exceed the pump's recommended tip size.

The following chart indicates the most common sizes and the appropriate materials to be sprayed.

Tip Size	Spray Material	Filter Type
.011 - .013	Laquers and stains	100 mesh filter
.015 - .019	Oil and latex	50 mesh filter
.021 - .026	Heavy bodied latex and blockfillers	5 mesh filter

Fan widths measuring 8" to 12" (20 to 30 cm) are most preferred because they offer more control while spraying and are less likely to plug.

Limited Warranty

Titan Tool, Inc., ("Titan") warrants that at the time of delivery to the original purchaser for use ("End User"), the equipment covered by this warranty is free from defects in material and workmanship. With the exception of any special, limited, or extended warranty published by Titan, Titan's obligation under this warranty is limited to replacing or repairing without charge those parts which, to Titan's reasonable satisfaction, are shown to be defective within twelve (12) months after sale to the End User. This warranty applies only when the unit is installed and operated in accordance with the recommendations and instructions of Titan.

This warranty does not apply in the case of damage or wear caused by abrasion, corrosion or misuse, negligence, accident, faulty installation, substitution of non-Titan component parts, or tampering with the unit in a manner to impair normal operation.

Defective parts are to be returned to an authorized Titan sales/service outlet. All transportation charges, including return to the factory, if necessary, are to be borne and prepaid by the End User. Repaired or replaced equipment will be returned to the End User transportation prepaid.

THERE IS NO OTHER EXPRESS WARRANTY. TITAN HEREBY DISCLAIMS ANY AND ALL IMPLIED WARRANTIES INCLUDING, BUT NOT LIMITED TO, THOSE OF MERCHANTABILITY AND FITNESS FOR A PARTICULAR PURPOSE, TO THE EXTENT PERMITTED BY LAW. THE DURATION OF ANY IMPLIED WARRANTIES WHICH CANNOT BE DISCLAIMED IS LIMITED TO THE TIME PERIOD SPECIFIED IN THE EXPRESS WARRANTY. IN NO CASE SHALL TITAN LIABILITY EXCEED THE AMOUNT OF THE PURCHASE PRICE. LIABILITY FOR CONSEQUENTIAL, INCIDENTAL OR SPECIAL DAMAGES UNDER ANY AND ALL WARRANTIES IS EXCLUDED TO THE EXTENT PERMITTED BY LAW.

TITAN MAKES NO WARRANTY AND DISCLAIMS ALL IMPLIED WARRANTIES OF MERCHANTABILITY AND FITNESS FOR A PARTICULAR PURPOSE WITH RESPECT TO ACCESSORIES, EQUIPMENT, MATERIALS OR COMPONENTS SOLD BUT NOT MANUFACTURED BY TITAN. THOSE ITEMS SOLD, BUT NOT MANUFACTURED BY TITAN (SUCH AS GAS ENGINES, SWITCHES, HOSES, ETC.) ARE SUBJECT TO THE WARRANTY, IF ANY, OF THEIR MANUFACTURER. TITAN WILL PROVIDE THE PURCHASER WITH REASONABLE ASSISTANCE IN MAKING ANY CLAIM FOR BREACH OF THESE WARRANTIES.

Patents

These products are covered by one or more of the following U.S. patents:

5,947,381 5,749,528 5,660,332 5,425,506 4,611,758 4,508,268

Material Safety Data Sheets (MSDS) are available on Titan's website or by calling Customer Service.



United States Sales & Service
1-800-526-5362
Fax 1-800-528-4826

Canadian Branch
1-800-565-8665
Fax 1-905-856-8496

International
1-201-337-1240
Fax 1-201-405-7449



107 Bauer Drive
Oakland, NJ 07436

200 Trowers Road, Unit 7B
Woodbridge, Ontario L4L 5Z8

107 Bauer Drive
Oakland, NJ 07436 USA

www.titantool.com

