

TITAN[®] TOOL INC.



OWNER'S MANUAL
FOR PROFESSIONAL
USE ONLY

313 - 1015 0699

REV B

TITAN *Speeflo* CE SA

DO NOT USE EQUIPMENT BEFORE READING THIS MANUAL

PowrTwin 4500™



PowrTwin 4500™ Airless Sprayer WARNING HIGH PRESSURE DEVICE

Model Numbers 448-650
448-653
448-655
448-656
448-657
448-658



This manual contains important warnings and instructions.
Please read and retain for reference. Never operate this unit unless it is properly grounded.



Table of Contents

Specifications3
 Safety Warnings5
 Operating Controls8
 Setup9
 Fueling9
 Startup10
 Color Change / Clean Out / Flushing10
 Maintenance11, 12

Troubleshooting Guide

Airless Spraying13
 Spray Patterns14
 Hydraulic Motors15
 Fluid Pumps15

Parts List, Drawings and Service Instructions

Model Descriptions / Major Components16
 Power Convertokits17, 18, 19
 Cart Assembly20
 Hydraulic System21
 Hydraulic Motor22, 23
 Fluid Pump24, 25, 26
 Bleed Line/Syphon Hose27
 Outlet Manifold Filter Assembly28

Key Accessories & Service Kits29, 30, 31
Warranty32

PowrTwin 4500™

Congratulations on having selected the finest airless sprayer available in the world. Titan/Speeflo piston pumps are tireless workhorses - so tough they are virtually indestructible, even under the most severe service. Titan/Speeflo designs and builds equipment with superior quality and reliability. Equipment that will last for years with minimal maintenance and downtime. This equipment will make you money year after year. We thank you for your purchase and welcome you to our large and growing family of Titan/Speeflo users.

The unique ability of this *PowrTwin 4500™* to operate with either gas or electric power provides you with the flexibility to work indoors or outside where no electricity is available.

Hydraulic drive makes possible the longest stroke and slowest cycling pumps in the industry which translates into low maintenance and longer life. Electric units operate quietly with no motor starting and stopping.

The *PowrTwin 4500™* is equipped with Titan/Speeflo's exclusive and patented Severe Service 500™ fluid pump. This technology will give you significantly longer rod, cylinder, and packing life than any other sprayer built in the world. This double ball piston pump employs a dependable and durable time-tested design. All pumps

use an exclusive thick hard chrome plating on rod and cylinder parts. This patented plating process is harder than nitralloy, stainless steel, or hard chrome used by any other paint pump manufacturer and much more abrasion resistant. Highly polished parts reduce friction, extend packing life, and avoid damage from corrosion and abrasion. More than 75,000 of these pumps are in operation around the world.

PowrTwin 4500™ offers other cost saving features:

- Variable Pressure Control
- Choice of Power - Gas or Electric
- Tungsten Carbide Valve Seats
- Self-Adjusting Packings
- Exclusive Hand-Tight Swivel Foot Valve
- Large Capacity Inline Paint Filter
- "Floating Ball" Pressure Bleed Valve
- 5 Gallon Syphon Hose and Bleed Line Assemblies are standard.

You have made an excellent choice. We know you will be pleased with your new *PowrTwin 4500™*. Thanks again for selecting Titan/Speeflo. We appreciate your business.



WARNING: The Engine Exhaust from this product contains chemicals known to the State of California to cause cancer, birth defects, or other reproductive harm.

U.S. Patents: 3,936,002; 4,220,286; 4,457,472; 4,508,268; 4,494,697; 4,500,119; 4,626,004; 4,611,758; 4,744,571; 4,728,213; 4,768,932; 4,755,638; 4,768,929; 4,840,543; 4,908,538; 5,074,467; 5,425,506

SPECIFICATIONS

Gas Powered Units

Delivery (GPM) (LPM)	1.3 5.0
Cycle Rate (Gallon)	87
Cycles per Minute (Maximum)	113
Maximum Tip Size - 1 Gun	.036"
Maximum Tip Size - 2 Guns	.026"
Maximum Tip Size - 3 Guns	.019"
Pressure Range (psi)	400 - 3000
Pressure Range (bar)	28 - 207
Power	Honda 4.0 hp, 4-Stroke, Single Cylinder, Overhead Valve Engine With Oil Alert
Fuel Capacity	0.66 US Gallons (Approximately 3 hours run time)
Halogenated Solvent Compatible	Yes
Weight	139 Lbs. (63 Kg.)
Inlet Paint Filter	10 Mesh "Rock Catcher"
Outlet Paint Filter	50 Mesh, 18 in. ²
Pump Inlet	3/4" NPT(F)
Pump Outlet	1/2" NPT(F) to Paint Filter
Paint Filter Hose Connections	(1) - 1/4" NPSM(M) (1) - 1/4" NPT(F) Plugged
Dimensions	31" H (787 mm) x 34" L (864 mm) x 23" W (584 mm)
Fluid Pump Wetted Parts	Electroless nickel plated ductile iron, electroless nickel plated carbon steel, proprietary Severe Service 500™ hard chrome anti-wear surface, stainless steel, tungsten carbide, UVØØ, thiokol impregnated leather, ultra high molecular weight polyethylene.

Electric Units

	DC - Electric
Delivery (GPM) (LPM)	1.1 4.2
Cycle Rate (Gallon)	87
Cycles per Minute (Maximum)	96
Maximum Tip Size - 1 Gun	.031"
Maximum Tip Size - 2 Guns	.023"
Maximum Tip Size - 3 Guns	.017"
Pressure Range (psi)	400 - 3000
Pressure Range (bar)	28 - 207
Power	2 HP DC Motor 115V, 16 AMP 230V, 8 AMP Overload Protected
Halogenated Solvent Compatible	Yes
Weight	159 Lbs. (72 Kg.)
Inlet Paint Filter	10 Mesh "Rock Catcher"
Outlet Paint Filter	50 Mesh, 18 in. ²
Pump Inlet	3/4" NPT(F)
Pump Outlet	1/2" NPT(F) to Paint Filter
Paint Filter Hose Connections	(1) - 1/4" NPSM(M) (1) - 1/4" NPT(F) Plugged
Dimensions	31" H (787 mm) x 34" L (864 mm) x 23" W (584 mm)
Fluid Pump Wetted Parts	Electroless nickel plated ductile iron, electroless nickel plated carbon steel, proprietary Severe Service 500™ hard chrome anti-wear surface, stainless steel, tungsten carbide, UVØØ, thiokol impregnated leather, ultra high molecular weight polyethylene.

WARNING: DO NOT use this equipment to spray water or acid.

CAUTION: Do not lift by cart handle when loading or unloading.

WARNING LABELS

Your sprayer has the English language Warning Label shown on Page 5 in the location indicated below. If you require this label in French, German, or Spanish, or require additional English labels, order directly from Titan free of charge. Call toll free 1-800-526-5362.

PART NO.	LANGUAGE
313-771 313-784	English
313-1306 313-1307	Spanish
313-785 313-786	French
313-787 313-788	German

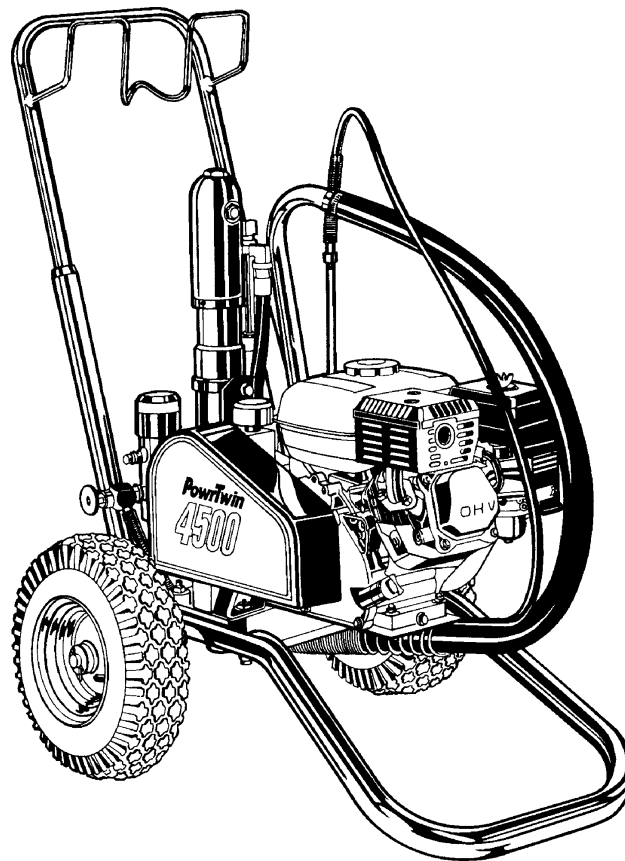

GASOLINE ENGINE SAFETY

1. Honda engines are designed to give safe and dependable service if operated according to instructions. Read and understand the Honda Owner's Manual before operating the engine. Failure to do so could result in personal injury or equipment damage.

2. To prevent fire hazards and to provide adequate ventilation, keep the engine at least 1 meter (3 feet) away from buildings and other equipment during operation. Do not place flammable objects close to the engine.

3. Children and pets must be kept away from the area of operation due to a possibility of burns from hot engine components or injury from any equipment the engine may be used to operate.

4. Know how to stop the engine quickly, and understand the operation of all controls. Never permit anyone to operate the engine without proper instructions.

5. Gasoline is extremely flammable and is explosive under certain conditions.

6. Refuel in a well-ventilated area with the engine stopped. Do not smoke or allow flames or sparks in the refueling area or where gasoline is stored.

7. Do not overfill the fuel tank. After refueling, make sure the tank cap is closed properly and securely.

8. Be careful not to spill fuel when refueling. Fuel vapor or spilled fuel may ignite. If any fuel is spilled, make sure the area is dry before starting the engine.

9. Never run the engine in an enclosed or confined area. Exhaust contains poisonous carbon monoxide gas; exposure may cause loss of consciousness and may lead to death.

10. The muffler becomes very hot during operation and remains hot for a while after stopping the engine. Be careful not to touch the muffler while it is hot. To avoid severe burns or fire hazards, let the engine cool before transporting it or storing it indoors.

11. **Never ship/transport unit with gasoline in tank.**

DO NOT USE EQUIPMENT BEFORE READING THIS SECTION

WARNING

HIGH PRESSURE SPRAY CAN CAUSE SERIOUS INJURY

Maximum Working Pressure 3000 psi, 207 bar

An airless spray gun requires that fluid be introduced to it at very high pressure. Fluids under high pressure, from spray or leaks, can penetrate the skin and inject substantial quantities of toxic fluid into the body. If not promptly and properly treated, the injury can cause tissue death or gangrene and may result in serious, permanent disability or amputation of the wounded part. Therefore, extreme caution must be exercised when using any airless spray equipment. **IF YOU ARE INJECTED, SEE A PHYSICIAN IMMEDIATELY. DO NOT TREAT AS A SIMPLE CUT!**

NOTE TO PHYSICIAN: Injection into the skin is a serious, traumatic injury. It is important to treat the injury surgically as soon as possible. Do not delay treatment to research toxicity. Toxicity is a concern with some exotic coatings injected directly into the bloodstream. Consultation with a plastic surgeon or a reconstructive hand surgeon may be advised.

1) Handle the spray gun carefully. Keep clear of the nozzle. **NEVER** point the gun at yourself or anyone else. **NEVER** permit any part of your body to come in contact with the fluid stream of either the gun or any hose leak. **ALWAYS** keep the gun trigger safety lever in a locked position when not spraying. **ALWAYS** use a tip safety guard.

2) **NEVER** attempt to force the flow of fluid backward through the gun with your finger, hand or hand-held object against the gun nozzle. **THIS IS NOT AN AIR SPRAY GUN.**

3) **NEVER** attempt to remove tip, disassemble or repair equipment without first doing

the following:

4) Before flushing system, always remove spray tip and adjust fluid pressure to lowest possible setting.

5) Tighten all fluid connections before each use. **NEVER** exceed 3000 psi (207 bar) with this unit. Make sure that all accessory hoses, connections, swivels and so forth can withstand the high pressures which develop. **NEVER** exceed the pressure rating of any component in the system.

6) **WARNING:** The paint hose can develop leaks from wear, kinking, abuse, etc. A leak is capable of injecting fluid into the skin, therefore the paint hose should be inspected before each use. **NEVER** attempt to plug a hose with any part of your body, adhesive tape or any other makeshift device. Do not attempt to repair a spray hose. Instead, replace it with a new grounded hose. Use only with hoses that have spring guards. **NEVER** use less than 50' (15.2m) of hose with this unit.

7) Be sure that the airless equipment being used and the object being sprayed are properly grounded to prevent static discharge or sparks which could cause fire or explosion.

WARNING: ALWAYS hold the gun against metal container when flushing system with tip removed, to prevent static discharge. **CAUTION:** To reduce the risk of electrical shock, do not expose to rain. Store indoors.

GROUNDING INSTRUCTIONS: This product should be grounded. In the event of an electrical short circuit, grounding reduces the risk of electric shock by providing an escape

plug is necessary, do not connect the grounding wire to either flat blade terminal. The wire with insulation having an outer surface that is green (with or without yellow stripes) is the grounding wire. Check with a qualified electrician or serviceman if the grounding instructions are not completely understood, or if in doubt as to whether the product is properly grounded. Do not modify the plug provided; if it will not fit the outlet, have the proper outlet installed by a qualified electrician.

- This product is for use on a nominal 120-volt circuit and has a grounding plug that looks like the plug illustrated below.
- Make sure that the product is connected to an outlet having the same configuration as the plug. No adapter should be used with this product.

EXTENSION CORDS: Use only a 3-wire extension cord that has a 3-slot receptacle that will accept the plug on the pump. Make sure your extension cord is in good condition. When using an extension cord, be sure to use one heavy enough to carry the current this pump will draw.

For lengths less than	Use extension gauge
25 ft. (7.5 meters)	16 AWG
50 ft. (15 meters)	14 AWG
100 ft. (30 meters)	12 AWG
150 ft. (45 meters)	10 AWG

An undersized cord will cause a drop in line voltage resulting in loss of power and overheating. If in doubt, use the next heavier gauge. The smaller the gauge number, the heavier the cord.

8) **ALWAYS** keep the working area around the pump well ventilated. Additionally, the pump itself should be a minimum of 25' (7.5m) from the spray area. If these instructions are not followed, there is the possibility of fire or explosion with certain materials.

ALWAYS follow the coating or solvent manufacturer's safety precautions and warnings. Never spray flammable material near open flames, pilot lights or any source of ignition.

9) **ALWAYS** wear spray masks and protective eyewear while spraying. Additional personal protective equipment may be required depending on the type of material being sprayed and conditions of ventilation. Always contact supplier of material being sprayed for recommendation.

10) Keep all extension poles clear of electrical wires.

11) **NEVER** alter or modify any part of this equipment; doing so could cause it to malfunction.

12) **NEVER** leave equipment unattended. Keep away from children or anyone not familiar with the operation of airless equipment.

IMPORTANT -- PRESSURE RELIEF PROCEDURE

ALWAYS reduce pressure when you are cleaning a clogged tip, changing a tip, servicing any part of the system, or shutting down. Follow the steps below:

1. Engage the gun trigger lock.
2. Shut off the power source.
3. Close the orange handle shut-off ball valve on the hydraulic pressure hose.
4. Open the Pressure Bleed Valve by turning it counterclockwise at least three full turns.
5. Disengage the gun trigger lock and hold trigger open until flow of material stops.
6. Be certain to hold a metal part of the gun firmly to the side of a grounded metal container.
7. Reset trigger safety to locked position.

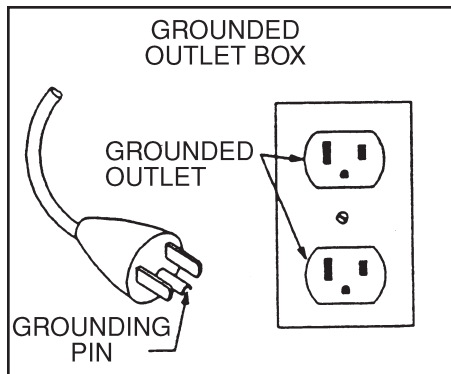

wire for the electric current. This product is equipped with a cord having a grounding wire with an appropriate grounding plug. The plug must be plugged into an outlet that is properly installed and grounded in accordance with all local codes and ordinances.

DANGER - Improper installation of the grounding plug can result in a risk of electric shock. If repair or replacement of the cord or

NO USE EL EQUIPO ANTES DE LEER ESTA SECCION

ADVERTENCIA LA ROCIADURA A PRESION ALTA PUEDE CAUSAR LESION GRAVE.

Presión de Trabajo Máxima 3000 libras por pulgada cuadrada (psi), 207 bar

Una pistola rociadora sin aire requiere que se le introduzca líquido a presión muy alta. Los líquidos bajo presión alta, de la rociadura o de las fugas, pueden penetrar en la piel e inyectar en el cuerpo cantidades considerables de líquido tóxico. Si no se atiende rápida y apropiadamente, la lesión puede causar muerte del tejido o gangrena, y puede resultar en incapacidad seria y permanente o en la amputación de la parte lesionada. Por lo tanto, hay que emplear precauciones estrictas al usar cualquier equipo de rociadura sin aire. **SI USTED HA ESTADO EXPUESTO A LA PENETRACION DE TOXICOS POR INYECCION, CONSULTE INMEDIATAMENTE AL MEDICO. ¡NO TRATE LA HERIDA COMO SI FUERA UNA MERA CORTADURA!**

NOTA PARA EL MEDICO: La penetración de tóxicos en la piel es una herida seria y traumática. Es importante tratar la herida quirúrgicamente lo más pronto posible. No demore el tratamiento para investigar la toxicidad. La toxicidad es asunto serio cuando se trata de la penetración de ciertos revestimientos tóxicos en la corriente sanguínea. Puede que sea necesaria la consulta con un cirujano plástico o un cirujano especialista en la reconstrucción de la mano.

1) Maneje la pistola de rociadura con cuidado. Manténgase alejado de la boquilla. **JAMAS** apunte la pistola hacia usted u otra persona. **NUNCA** permita que parte alguna de su cuerpo se ponga en contacto con el chorro de líquido de la pistola o de alguna fuga de la manguera. **SIEMPRE** mantenga trabado el seguro de la pistola mientras no esté rociando. **SIEMPRE** utilice el protector de seguridad de la boquilla.

2) **JAMAS** intente forzar el flujo del líquido por la pistola hacia atrás con el dedo, la mano o un objeto sostenido con la mano contra la boquilla de la pistola, ya que **NO SE TRATA DE UNA PISTOLA DE ROCIADURA DE AIRE**.

3) **JAMAS** intente quitar la boquilla ni desarmar o reparar el equipo sin haber cumplido antes con los pasos siguientes:

IMPORTANT -- PRESSURE RELIEF PROCEDURE

ALWAYS reduce pressure when you are cleaning a clogged tip, changing a tip, servicing any part of the system, or shutting down. Follow the steps below:

1. Engage the gun trigger lock.
2. Shut off the power source.
3. Close the orange handle shut-off ball valve on the hydraulic pressure hose.
4. Open the Pressure Bleed Valve by turning it counterclockwise at least three full turns.
5. Disengage the gun trigger lock and hold trigger open until flow of material stops.
6. Be certain to hold a metal part of the gun firmly to the side of a grounded metal container.
7. Reset trigger safety to locked position.

4) Antes de lavar el sistema, siempre quite la boquilla de rociadura y ajuste la presión del líquido al valor más bajo posible.

5) Ajuste todas las conexiones antes de cada uso. **JAMAS** supere 3000 libras (207 bar) por pulgada cuadrada con esta unidad. Asegúrese de que todas las mangueras, conexiones, articulaciones giratorias y demás elementos accesorios estén en condiciones de tolerar las altas presiones que se presentan. **JAMAS** exceda la clasificación de presión de cualquier componente del sistema.

6) **ADVERTENCIA:** La manguera de pintura puede presentar fugas como resultado del desgaste, retorcimiento, abuso, etc. Las fugas pueden inyectar líquido a través de la piel, por lo que la manguera de pintura debe ser inspeccionada antes de cada uso. **JAMAS** intente obturar la manguera con una parte de su cuerpo o con tela adhesiva o cualquier otro elemento improvisado. No intente reparar una manguera de rociadura; en cambio reemplácela con una manguera nueva conectada a tierra. Utilice solamente mangueras con protector de resorte. **JAMAS** use una manguera de menos de 15,2 m con esta unidad. Almacenar bajo techo.

INSTRUCCIONES PARA LA PUESTA A TIERRA: Este producto debe conectarse a tierra. En caso de corto circuito, la conexión a tierra proporciona una vía de escape para la corriente eléctrica y reduce el riesgo de choques eléctricos. El producto está dotado de un cable provisto de un alambre y de un enchufe de puesta a tierra. El enchufe debe enchufarse en un tomacorriente debidamente instal-

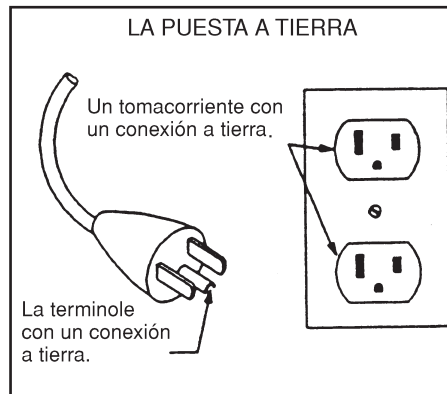

ado y dotado de conexión a tierra, de acuerdo con las estipulaciones de los códigos y ordenanzas locales.

PELIGRO — La instalación incorrecta del enchufe de puesta a tierra podría crear el riesgo de choque eléctrico. Si es necesario reparar o reemplazar el cordón o el enchufe, no conecte el alambre de puesta a tierra a ninguna de las dos terminales de cuchilla plana. El alambre con aislamiento exterior verde, con o sin rayas amarillas, es el alambre de puesta a tierra. Consulte a un electricista o técnico competente si no comprende bien las instrucciones para la conexión a tierra o si tiene dudas de que el producto está conectado a tierra correctamente. No modifique el enchufe que viene con el producto; si no encaja en el tomacorriente, pida a un electricista competente que instale el tomacorriente apropiado.

• Este producto ha sido diseñado para usarse en

un circuito de tensión nominal de 120 voltios y está dotado de un enchufe de puesta a tierra semejante a la ilustrada más adelante.

• Asegúrese de que el producto esté enchufado en un tomacorriente que tenga la misma configuración del enchufe. No debe usarse ningún adaptador.

CORDON DE EXTENSION — Use sólo un cordón de extensión trifilar que tenga un enchufe de puesta a tierra con tres cuchillas, y un receptáculo con tres ranuras que acepte el enchufe que viene con el producto. Cerciórese de que el cordón de extensión esté en buen estado. Al usar un cordón de extensión, cerciórese de que sea suficientemente grueso para transportar la corriente que su producto usará.

Para tramos de menos de: Use cordones de calibre:

7,6 m	16 AWG
15,2 m	14 AWG
30,4 m	12 AWG
45,7 m	10 AWG

Un cordón demasiado corto provocará una caída de la tensión, ocasionando una pérdida de potencia y recalentamiento. Si tiene dudas, use un calibre más grueso. Cuanto más pequeño sea el número de calibre, más grueso será el cable.

7) Asegúrese de que el equipo sin aire que esté empleando y el objeto que se intenta rociar estén correctamente conectados a tierra para evitar descargas estáticas o chispas que podrían ocasionar incendio o explosión. **ADVERTENCIA:** Sostenga **SIEMPRE** la pistola contra el receptáculo de metal al limpiar el sistema con la boquilla desprendida, para evitar la descarga estática. **ADVERTENCIA:** Para reducir riesgo de descarga eléctrica, no exponer a la lluvia.

8) **SIEMPRE** mantenga el lugar de trabajo alrededor de la bomba bien ventilado. Además, la bomba en sí debe estar ubicada a no menos de 7,6 m de la operación de rociadura. Si no se observan estas instrucciones, existe el riesgo de incendio o explosión con ciertos materiales. **SIEMPRE** observe las precauciones y advertencias de los fabricantes sobre revestimientos y solventes. Nunca rocíe material inflamable cerca de llamas expuestas, llamas piloto o cualquier fuente de ignición.

9) **SIEMPRE** use máscaras apropiadas y anteojos de protección durante la operación de rociadura. Según el tipo de material que se está rociando y las condiciones de ventilación puede ser necesario usar equipo personal protector adicional. Siempre comuníquese con el proveedor del material para conseguir recomendaciones.

10) Mantenga todas las varas de extensión fuera del alcance de cables eléctricos.

11) **JAMAS** altere o modifique parte alguna de este equipo, ya que ello puede causar deficiencias de funcionamiento.

12) **JAMAS** deje al equipo solo. Manténgalo fuera del alcance de los niños o de cualquier persona no familiarizada con la operación de equipo sin aire.

NE PAS UTILISER LE MATERIEL AVANT D'AVOIR LU CETTE SECTION

ATTENTION!

LES PULVERISATEURS A HAUTE PRESSION PEUVENT PROVOQUER DE SERIEUSES LESIONS

Pression de travail maximale: 3000 psi — 207 bar

Le liquide introduit dans un pistolet pulvérisateur sans air doit être à pression extrêmement élevée. Les liquides à haute pression, en provenance du pulvérisateur ou d'une fuite quelconque, sont capables de pénétrer la peau et d'injecter d'importantes quantités de liquide toxique dans l'organisme. Si elle n'est pas traitée promptement et avec toute l'attention voulue, la lésion causée de la sorte peut provoquer la nécrose des tissus ou la gangrène et donner lieu à de sérieux handicaps permanents, voire à l'amputation du membre atteint. Une prudence extrême s'impose donc lors de l'utilisation de matériel de pulvérisation sans air. **EN CAS D'INJECTION, CONSULTEZ UN MEDECIN IMMEDIATEMENT. NE TRAITÉZ PAS LA BLESSURE COMME S'IL S'AGISSAIT D'UNE SIMPLE COUPEURE!**

REMARQUE A L'INTENTION DU MEDECIN :

Une injection pénétrant la peau constitue une lésion traumatique grave qu'il est important de traiter chirurgicalement aussitôt que possible. Ne perdez pas de temps à rechercher la toxicité de l'injection. Il s'agit là d'un risque à envisager en cas d'injection directe dans le circuit sanguin de certains revêtements exotiques. La consultation d'un chirurgien plasticien ou d'un spécialiste de la chirurgie reconstructive de la main peut être conseillée.

1) Maniez le pistolet avec soin. Maintenez-vous à l'écart de la buse. N'en dirigez **JAMAIS** la buse vers aucune partie de votre corps ou vers aucune autre personne. Ne laissez **JAMAIS** aucune partie de votre corps entrer en contact avec le flux de liquide s'échappant du pistolet ou d'une fuite quelconque au niveau du flexible. Verrouillez **TOUJOURS** le levier de sûreté de la détente lorsque vous n'êtes pas occupé à pulvériser. **Veillez à TOUJOURS utiliser un dispositif de sûreté à la buse du pistolet.**

2) N'essayez **JAMAIS** de refouler le flux de liquide dans le pistolet au moyen de votre doigt, de votre main ou d'un objet maintenu contre la buse du pistolet. **CET APPAREIL N'EST PAS UN PISTOLET PULVERISATEUR A AIR.** N'utilisez aucune pièce de matériel sans air avec une pompe non équipée d'une

soupage de surpression.

3) N'essayez **JAMAIS** d'enlever la buse, de démonter ou de réparer l'appareil avant d'avoir accompli la procédure suivante :

4) Avant de procéder au rinçage du système, enlevez toujours la buse de pulvérisation et réglez la pression au niveau le plus faible possible.

5) Serrez bien tous les raccords du système hydrodynamique avant chaque emploi. Ne dépassez **JAMAIS**, avec cet appareil, une pression de 3000 psi (207 bar). Assurez-vous que tous les flexibles accessoires, raccords, articulations, etc. sont bien capables de résister aux hautes pressions prévues. Ne dépassez **JAMAIS** la capacité de pression nominale d'aucun composant du système. **DANGER** : Afin de réduire tout risque d'électrocution, n'exposez pas à la pluie.

6) **ATTENTION** : Des fuites risquent de se produire le long du flexible de peinture sous l'effet de l'usure, des torsions, des rudes traitements, etc. auxquels il est éventuellement soumis. Les injections de liquide dans la peau sont possibles par la voie de telles fuites. Il est donc important d'inspecter le flexible avant chaque usage. N'essayez **JAMAIS** d'obturer une fuite à l'aide de votre doigt ou de tout autre membre de votre corps, de ruban adhésif ou de tout autre moyen de fortune. N'essayez pas non plus de réparer un flexible de pulvérisation ; remplacez-le plutôt par un nouveau flexible mis à la terre. Veillez à n'utiliser que les flexibles munis de dispositifs de sécurité à ressort. N'utilisez **JAMAIS** moins de 15,2 m de flexible avec cet appareil.

7) Assurez-vous que le matériel sans air utilisé et que l'objet à peindre sont adéquatement mis à la terre, de façon à éviter toute décharge d'électricité statique ou toute étincelle susceptible de provoquer un incendie ou une explosion. **ATTENTION** : Tenez **TOUJOURS** le pistolet contre un récipient en métal lors du rinçage du système, après en avoir ôté la buse. Ne vaporisez **JAMAIS** de substances inflammables à proximité de flammes nues, lampes témoin ni d'aucune source d'allumage. Rangez à l'intérieur.

INSTRUCTIONS DE MISE A LA TERRE : Ce produit doit être mis à la terre. Dans l'hypothèse d'un court-circuit électrique, la mise à la terre réduit le risque de chocs électriques en assurant un fil de fuite pour le courant électrique. Ce produit est pourvu d'un cordon possédant un fil de terre avec fiche appro-

préciations locales.

DANGER - La pose inappropriée de la fiche de terre peut provoquer un risque de chocs électriques. Si le cordon ou la fiche doit être réparé ou remplacé, ne raccordez pas le fil de terre à l'une ou l'autre borne à lame plate. Le fil possédant une isolation dont la surface extérieure est verte (avec ou sans rayures jaunes) est le fil de terre. Consultez un électricien ou un technicien de service compétent si vous ne comprenez pas parfaitement les instructions de mise à la terre ou si vous ne pouvez affirmer avec certitude que le produit est dûment mis à la terre. Ne modifiez pas la fiche fournie ; si elle ne rentre pas dans la prise, faites poser la prise appropriée par un électricien compétent.

- Ce produit est destiné à être utilisé sur un circuit à tension nominale de 120 volts et a une fiche de terre qui ressemble à la fiche illustrée ci-après.
- S'assurer que le produit est branché sur une prise ayant la même configuration que la fiche. Aucun adaptateur ne doit être utilisé avec ce produit.

CORDONS DE RALLONGE - Utilisez uniquement un cordon de rallonge à trois fils pourvu d'une fiche de mise à la terre à trois lames, et une prise à trois fentes qui acceptera la fiche de la pompe. Assurez-vous que votre cordon de rallonge est en bon état. Lorsque vous utilisez un cordon de rallonge, veillez à en utiliser un suffisamment puissant pour transporter le courant que consommera cette pompe.

Pour les longueurs

de moins de	Utilisez une rallonge de calibre
7,6 m	16 AWG
15,2 m	14 AWG
30,4 m	12 AWG
45,7 m	10 AWG

Un cordon sous-calibré provoquera une chute de tension secteur ayant pour conséquences une perte de puissance et une surchauffe. En cas de doute, utilisez le calibre immédiatement plus puissant. Plus le numéro de calibre est bas, plus le cordon est puissant.

8) Le moteur électrique de cet appareil n'est pas protégé contre les explosions. Il est donc essentiel d'assurer une bonne ventilation de la zone de travail et des alentours de la pompe. Il est également important de maintenir la pompe à une distance minimale de 7,6 m de la zone de pulvérisation. Certains matériels présentent, à défaut de suivre ces consignes, un risque d'incendie ou d'explosion. Suivez **TOUJOURS** les précautions et avertissements du fabricant de chaque solvant ou revêtement utilisé.

9) Portez **TOUJOURS** un masque et des lunettes de protection lors de vos travaux de pulvérisation. D'autres articles de protection personnelle peuvent être nécessaires suivant le type de produit pulvérisé et les conditions d'aération. Demandez toujours ses recommandations à votre fournisseur.

10) Maintenez toutes les tiges de rallonge à distance des fils électriques.

11) N'altérez ou ne modifiez **JAMAIS** une partie quelconque de cet appareil, ce qui pourrait causer des défaillances.

12) Ne laissez **JAMAIS** le matériel sans surveillance. Gardez-le hors de portée des enfants et de toute personne inexpérimentée quant à l'usage de matériel sans air.

IMPORTANT -- PRESSURE RELIEF PROCEDURE

ALWAYS reduce pressure when you are cleaning a clogged tip, changing a tip, servicing any part of the system, or shutting down. Follow the steps below:

1. Engage the gun trigger lock.
2. Shut off the power source.
3. Close the orange handle shut-off ball valve on the hydraulic pressure hose.
4. Open the Pressure Bleed Valve by turning it counterclockwise at least three full turns.
5. Disengage the gun trigger lock and hold trigger open until flow of material stops.
6. Be certain to hold a metal part of the gun firmly to the side of a grounded metal container.
7. Reset trigger safety to locked position.

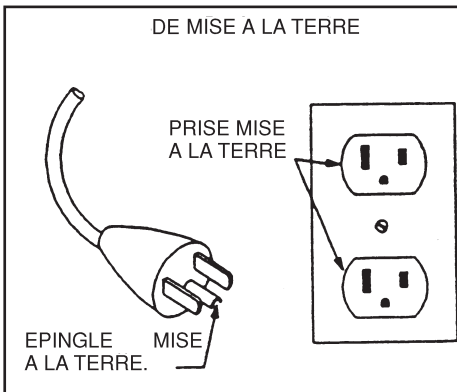

préciations de mise à la terre. La fiche doit être branchée sur une prise qui est posée et mise à la terre adéquatement conformément à tous les codes et

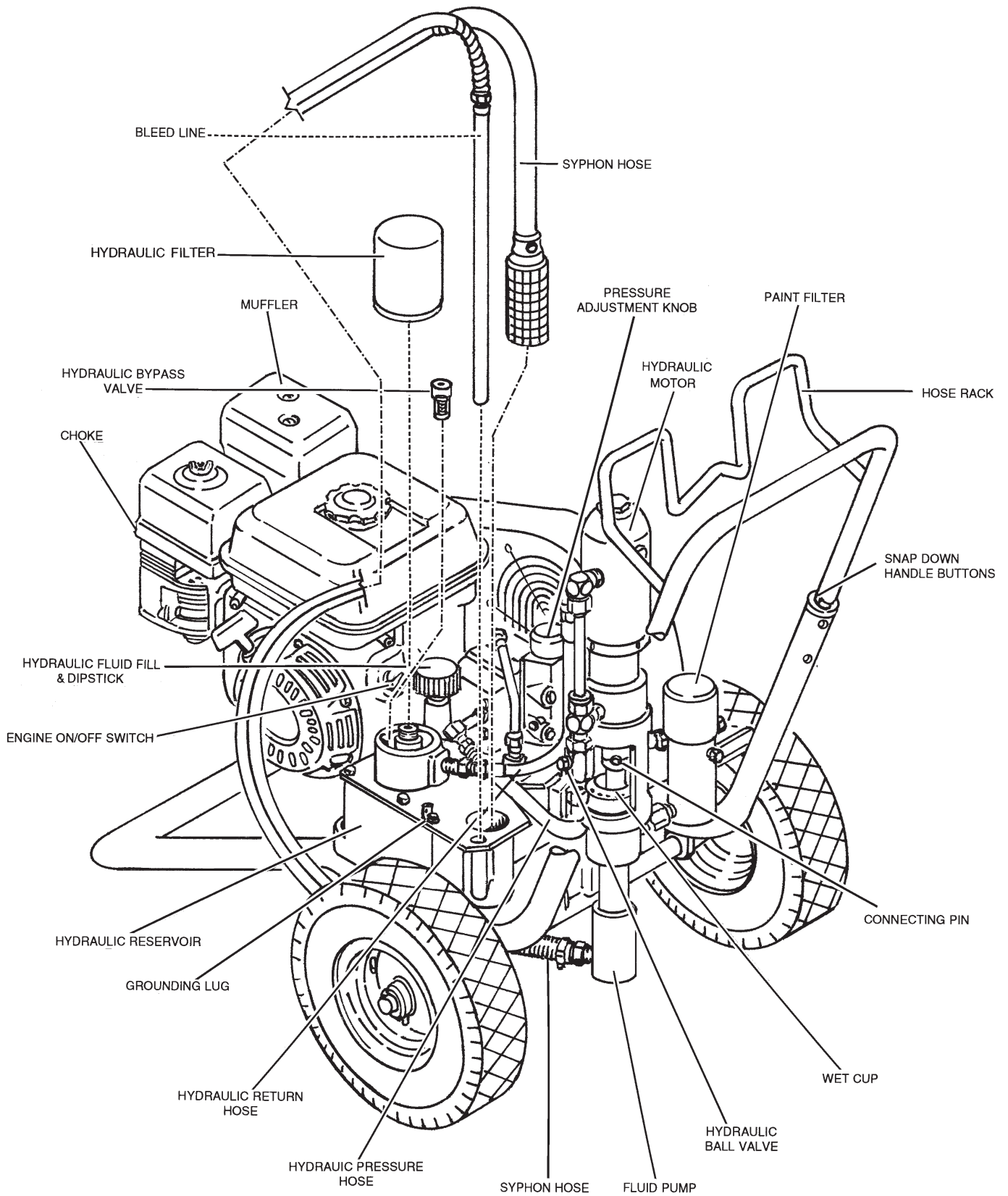

SET UP

WARNING: READ, UNDERSTAND AND FOLLOW ALL WARNINGS ON PAGES 4 - 7 BEFORE STARTING OR OPERATING THIS SPRAYER

Required tools: Crescent Wrench

1. Connecting the Hoses:

The syphon hose and the bleed line hose have factory installed tape on the male end of the hoses. Tighten the syphon hose and bleed line wrench tight. See Figure 1.

2. One Gun Operation - Attach the gun and hose. Always use a spray hose at least 50 feet long. Do not use or thread sealant on this assembly. Do not install the spray tip at this time.

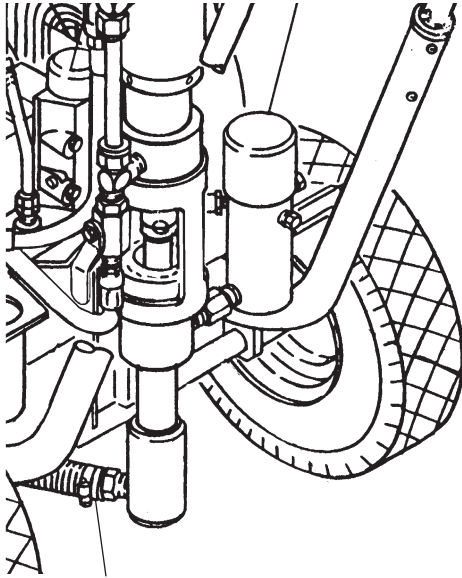

SYPHON HOSE

FIGURE 1

3. Two Gun Operation - Remove the plug from the second gun outlet. Connect a hose and a gun to the outlet.

4. Multiple Gun Operation - The PowrTwin 4500™ is engineered to handle up to 3 guns with 0.19" tips. When using more than two guns, make sure the second gun hookup outlet is plugged. Connect the multiple gun manifold to the single gun outlet. These manifolds are for either 2, 3, or 4-guns and have shut off valves. Connect a hose and gun to each outlet. See Figure 2.

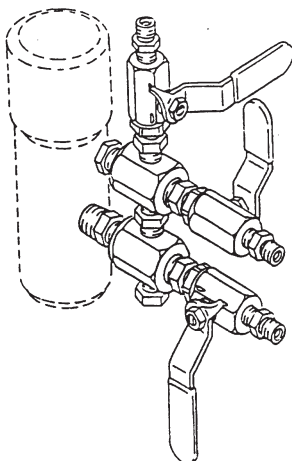

FIGURE 2

5. Fill the Wet-Cup 1/2 full with Titan/Speeflo's Piston Lube, Part No. 700-925, supplied by the factory. This extends packing life.

6. **Electric Models** - Use a 20 amp service outlet. Always locate the AC electric model within 10 to 15 feet of the service outlet. Use a short electric cable and a long paint hose. Any extension cord will create some voltage drop. For both AC and DC models, if an extension cord is necessary, use only grounded 3 wire # 12 wire.

If the unit is being operated in an area that is overloaded by other appliances or low voltage conditions, it is important to start the unit "unloaded." Tip the electric motor forward so that the belt is loosened and the motor starts without full load. This reduces the amperage draw on starting and may avoid kicking out the circuit breaker.

7. Be sure the PowrTwin system is grounded. All Titan/Speeflo units are equipped with a grounding lug. A grounding cable (not supplied) should be used to connect the unit to a true earth ground. Check your local electrical regulations for detailed grounding instructions. See Accessories, Page 31, for ordering information.

8. Strain all paints with Titan/Speeflo # 160-524 5 gallon Nylon Strainer or Titan/Speeflo # 160-124 1 gallon Nylon Strainer to assure trouble free operation and freedom from frequent cleaning of inlet screen and gun strainer.

WARNING: Proper grounding is important. This applies to both gas and electric powered models. The passage of some materials through the nylon fluid hose will build up a static electric charge, which if discharged, could ignite solvent vapors present and create an explosion.

FUELING

WARNING: Gasoline is extremely flammable and is explosive under certain conditions.

1. **ALWAYS** turn the engine off before refueling.

2. Refuel in a well-ventilated area.

3. Do not smoke or allow flames or sparks in the refueling area or where gasoline is stored.

4. Do not overfill the fuel tank. After refueling, make sure the tank cap is closed properly and securely.

5. Be careful not to spill fuel when refueling. Spilled fuel or fuel vapor may ignite. If any fuel is spilled, make sure the area is dry before starting the engine.

6. Avoid repeated or prolonged contact with skin or breathing of vapor.

KEEP OUT OF REACH OF CHILDREN.

Specifications:

Use automotive gasoline that has a pump octane number of 86 or higher, or that has a research octane number of 91 or higher.

Unleaded fuel produces fewer engine and spark plug deposits and extends the life of exhaust system components.

Never use stale or contaminated gasoline or an oil/gasoline mixture. Avoid getting dirt, dust or water in the fuel tank. Use of a lower octane gasoline can cause persistent "pinging" or heavy "spark knock" (a metallic rapping noise) which, if severe, can lead to engine damage.

NOTE: If "spark knock" or "pinging" occurs at a steady engine speed under normal load, change brands of gasoline. If spark knock or pinging persists, consult your authorized Honda dealer. Failure to do so is considered misuse, and damage caused by misuse is not covered by Honda's Limited Warranty. Occasionally you may experience light spark knock while operating under heavy loads. This is no cause for concern, it simply means your engine is operating efficiently.

Gasolines containing alcohol:

If you decide to use a gasoline containing alcohol (gasohol), be sure its octane rating is at least as high as that recommended by Honda. There are two types of "gasohol": one containing ethanol, and the other containing methanol. Do not use gasohol that contains more than 10% ethanol. Do not use gasoline containing methanol (methyl or wood alcohol) that does not also contain cosolvents and corrosion inhibitors for methanol. Never use gasoline containing more than 5% methanol, even if it has cosolvents and corrosion inhibitors.

NOTE: Fuel system damage or engine performance problems resulting from the use of fuels that contain alcohol is not covered under the warranty. Honda cannot endorse the use of fuels containing methanol since evidence of their suitability is as yet incomplete.

Before buying fuel from an unfamiliar station, try to find out if the fuel contains alcohol, if it does, confirm the type and percentage of alcohol used. If you notice any undesirable operating systems while using a gasoline that contains alcohol, or one that you think contains alcohol, switch to a gasoline that you know does not contain alcohol.

STARTUP

1. Areas must be well ventilated to prevent hazardous operation with volatile solvents or exhaust fumes.

WARNING: If lacquer or other flammable materials are to be sprayed, ALWAYS locate the unit outside the immediate spraying area. Failure to do so may cause an explosion.

2. Locate the unit outside the immediate spraying area to avoid clogged air intake of the engine or electric motor with overspray.
3. Before starting the unit, check oil levels.
 - A. The hydraulic fluid level should read "Full" on the dipstick. CHECK IT REGULARLY. See the Hydraulic System Maintenance Instructions on Page 11 for changing or adding hydraulic fluid. Do not overfill. Use only Titan/SpeeFlo Coolflo™ Hydraulic Fluid, Part No. 430-361.
 - B. The gasoline engine oil level is determined by the manufacturer. Check the manufacturer's service manual supplied.

IMPORTANT NOTE: Use of Titan/SpeeFlo's Coolflo™ Hydraulic Fluid is mandatory in the PowrTwin 4500™ hydraulic system. Do not use any other hydraulic fluid. Use of any other hydraulic fluid may seriously damage hydraulic system and will void warranty.

4. Open the orange handle shut-off valve located on the hydraulic pressure hose. Handle should be in line with hose. Figure 3 shows the handle in the open position.
5. Turn the Pressure Adjustment Knob counterclockwise (as viewed from top) to lowest pressure setting. See Figure 3.
6. Open the Pressure Bleed Valve by turning it counterclockwise. This relieves pressure. See Figure 4.

- A. Your new sprayer was tested at the factory with mineral spirits. You must clean the system before spraying to avoid contam

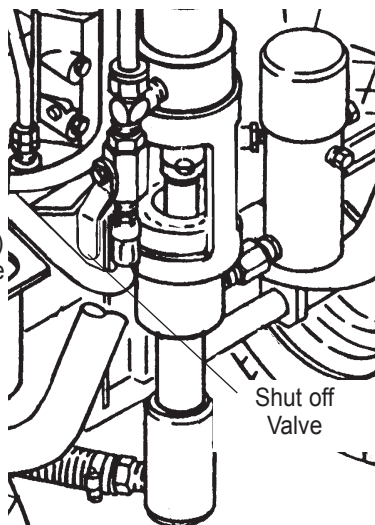

Figure 3

ination of the sprayed material.

If you are spraying a water based latex, flush with warm, soapy water followed by a clean water rinse. If you are using any other coating, flush with warm, soapy water followed by a solvent. Check with the material manufacturer for a compatible solvent.

Place syphon tube assembly into proper solvent or water.

- B. Place waste container below bleed line.
 - C. Start engine or electric motor. Turn Pressure Control Adjustment Knob clockwise (increasing pressure) until pump cycles evenly and solvent flows freely from bleed line.
 - D. Close Pressure Bleed Valve by turning it clockwise. This allows the system to pressurize. Hold gun trigger open, without spray tip attached, until the fluid flows smoothly. See Figure 4.
7. Repeat above starting procedure with paint material. Lock gun trigger and attach spray tip. See the Technical Data Sheet or Operator's Manual on the gun provided for installation and selection of the proper tip size.
 8. Test spray pattern. Operate the pump at the lowest hydraulic pressure which provides good atomization. See the Troubleshooting Guide if you are not getting the proper pattern.
 9. Operating pressure is adjustable from 400 to 3000 psi (207 bar) by turning the Pressure Adjustment Knob clockwise. Do not turn the knob clockwise more than necessary to provide satisfactory atomization. Excess pressure wears out spray tips.
 10. When restarting the unit, reduce the pressure at Pressure Control Adjustment Knob and Pressure Bleed Valve.

COLOR CHANGE / CLEAN OUT / FLUSHING

IMPORTANT -- PRESSURE RELIEF PROCEDURE

ALWAYS reduce pressure when you are cleaning a clogged tip, changing a tip, servicing any part of the system, or shutting down. Follow the steps below:

1. Engage the gun trigger lock.
2. Shut off the power source.
3. Close the orange handle shut-off ball valve on the hydraulic pressure hose.
4. Open the Pressure Bleed Valve by turning it counterclockwise at least three full turns.
5. Disengage the gun trigger lock and hold trigger open until flow of material stops.
6. Be certain to hold a metal part of the gun firmly to the side of a grounded metal container.

CLEANING A CLOGGED TIP

1. Follow the Pressure Relief Procedure above.
2. If tip clogs, rotate tip handle 180° until arrow on handle is facing the opposite of spray direction and clicks in reverse position.
3. Trigger gun once so that the pressure can blow the clog out. **NEVER** use the tip in the reverse position for more than **ONE** trigger pull at a time. This procedure can be repeated until the tip is free of clogging.

WARNING: THE FLOW FROM THE SPRAY TIP IS AT VERY HIGH PRESSURE. CONTACT WITH ANY BODY PART MAY BE DANGEROUS. DO NOT PLACE FINGER ON GUN OUTLET. DO NOT POINT THE GUN AT ANY PERSON. NEVER OPERATE THE SPRAY GUN WITHOUT THE PROPER TIP GUARD.

MAINTENANCE

HYDRAULIC SYSTEM

IMPORTANT INFORMATION: Use of Titan/Speeфло's Coolflo™ Hydraulic Fluid is mandatory in the PowrTwin 4500™ hydraulic system. Do not use any other hydraulic fluid. Use of any other hydraulic fluid will seriously damage hydraulic system and void warranty.

1. Check the hydraulic fluid daily. It should read "Full" on the dipstick. If it is low, add only Titan/Speeфло Coolflo™ Hydraulic Fluid, Part # 430-361. Never add or change hydraulic fluid except in a clean dust free area. Contamination of the hydraulic fluid will shorten Hydraulic pump life and may void warranty.

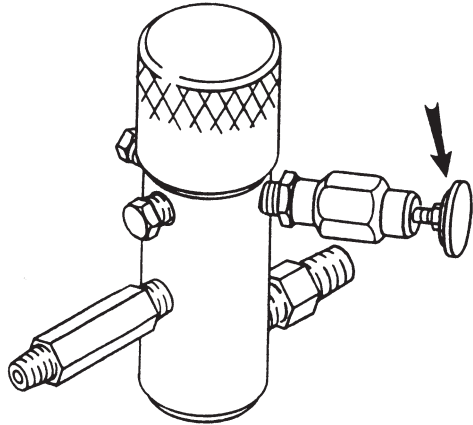

FIGURE 4

COLOR CHANGE / CLEAN OUT

CAUTION: USE ONLY COMPATIBLE SOLVENTS WHEN CLEANING OUT OIL BASED ENAMELS, LACQUERS, COAL TAR, AND EPOXIES. CHECK WITH THE FLUID MANUFACTURER FOR A RECOMMENDED SOLVENT.

1. Reduce pressure by turning the Pressure Adjustment Knob and the Pressure Bleed Valve on the bleed line counterclockwise. Follow the Pressure Relief Procedure above. The Pressure Bleed Valve should be turned counterclockwise at least three full turns.
2. Pull syphon tube out of material container.
3. Remove spray tip from gun. Hold gun trigger open until material flow stops.
4. Put syphon tube into wash solvent or water as applicable, and operate pump slowly at low pressure until solvent flows freely from Pressure Bleed valve line.
5. Close Pressure Bleed Valve and hold gun trigger open until solvent flows freely from gun. If solvent is not too dirty, recirculate it by flowing gun stream back into solvent container. Use additional clean solvent and repeat procedure if necessary.
6. Check gun strainer screen and pump outlet filter screen daily. Use 50 mesh screens with spray tip size .018 and larger. Use 100 or 200 mesh screens with spray tip sizes .015 and smaller.
7. Replace paint filter cap to maximum clockwise rotation. The filter cover should be hand removable after the first or second use with new UVØ O-Ring. **IMPORTANT:** O-Ring must have UVØ backup washer to seal properly.
8. If unit has been spraying a water soluble material, flush with water and then repeat procedure with mineral spirits or Varsol solvent.
9. Wash spray tip in solvent. Blow tip clean with air pressure directed through the tip in the reverse direction.

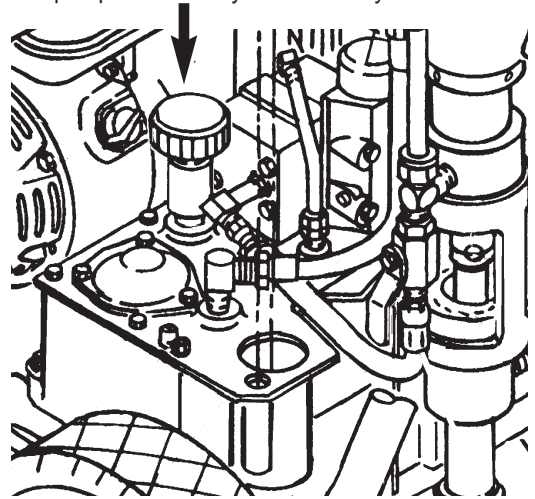

FIGURE 5

2. Change the hydraulic fluid every six months. Drain old fluid from tank and fill with 5 quarts of Titan/Speeфло Coolflo™ Hydraulic Fluid. Start operation of the system at just enough pressure to operate the fluid pump. Run the system at this low pressure for at least 5 minutes. This removes air from the system. Check the fluid level after this procedure.
3. The Hydraulic System has an external replaceable Hydraulic Filter. Change the filter every six months.
4. The Hydraulic Pump should not be serviced in the field. If service on the Hydraulic Pump is required, it must be returned to Titan/Speeфло.

GENERAL FLUID PUMP MAINTENANCE

If the paint pump is going to be out of service for an extended period of time, it is recommended that following cleanup a kerosene and oil mixture be introduced as a preservative. Packings may tend to dry out from lack of use. This is particularly true of the upper packing set for which upper packing lubricant, Piston Lube, Titan/Speeфло Part # 700-925, is recommended in normal usage. A sample of Lubrisolv accompanies each new unit. Do not substitute water or paint solvent for Lubrisolv. Ordinary oil may contaminate the paint material and is not recommended.

If the paint pump has been out of service for an extended period of time, it may be necessary to prime the suction by pouring some of the paint solvent into the inlet syphon tube to restart. It is extremely important that the threads on the inlet syphon hose coupling are properly sealed. Any air leakage will produce erratic operation of pump and may damage the system. The up and the down strokes should be approximately equal in time. That is, one should not be faster than the other. A fast up or down stroke may indicate air in the system or malfunctioning valve or seats. See the Troubleshooting Guide.

HYDRAULIC MOTOR & FLUID PUMP SERVICE

See Page 22 for maintenance and service instructions on the reciprocating hydraulic motor and Page 26 for the fluid pump.

BASIC ENGINE MAINTENANCE

- For detailed engine maintenance and technical specifications refer to the separate Honda engine manual.
- All service to the engine should be performed by an authorized Honda Power Equipment dealer. To locate a dealer in your area, look in the Yellow Pages of your telephone directory under Gasoline Engines, Garden & Lawn Equipment & Supplies, Lawnmowers, etc.
- The Honda engine is warranted exclusively by American Honda Motor Co., Inc.
- Use a premium quality motor oil certified to meet or exceed U.S. Automotive requirement SG.SF/CC.CD. SAE 10W30 is recommended for general all temperature use. Other viscosities may be required in other climates.
- Use only a (NGK) BP6ES or BPR6E spark plug. Gap the plug to 0.028 to 0.031 In. (0.7 to 0.8 mm) Always use a spark plug wrench.

DAILY: Check engine oil level. Fill as necessary. Check gasoline level. Fill as necessary.

WARNING: FOLLOW FUELING PROCEDURE ON PAGE 10

FIRST 20 HOURS: Change engine oil.

EVERY 100 HOURS: Change engine oil.

WEEKLY: Remove the air filter cover and clean the element. In very dusty environments, check the filter daily. Replace the element as needed. Replacement elements can be purchased from your local Honda dealer.

ENGINE OPERATION AND SERVICE

1. Clean and oil air filter pad on gasoline engine every 25 hours or once weekly. Do not permit the air intake screen around the fly wheel of the gas engine to load up with paint or trash. Clean it regularly. The service life and efficiency of the gas engine model depends upon keeping the gasoline engine running properly. Change the oil in the engine every 100 hours. Failure to observe this may result in engine overheating. Consult the engine manufacturer's service manual provided.
2. To conserve fuel, service life, and efficiency of the unit always operate the gasoline engine at the lowest RPM at which it runs smoothly without laboring and delivers the amount required for the particular painting operation. Higher RPM does not produce higher working pressure. The gasoline engine is connected to the hydraulic pump by a pulley combination designed to produce full paint delivery of 2.0 GPM at 3600 RPM.
3. The warranty on gasoline engines or electric motors is limited to the original manufacturer.

IMPORTANT ELECTRIC MOTOR INFORMATION

WARNING: If electric motor overloads and stops running, **IMMEDIATELY** turn the motor off and follow the Pressure Relief Procedure on Page 10. Wait until the motor cools (approximately 30 minutes). Then push in the bubble top, manual reset button, turn the motor on and pressurize the system.

**For CSA approved units only:
The ON / OFF switch is also the RESET!**

TROUBLESHOOTING AIRLESS GUN

PROBLEM	PROBABLE CAUSE	REMEDY
Spitting gun	<ol style="list-style-type: none"> 1. Air in system 2. Dirty gun 3. Needle assembly out of adjustment 4. Broken or chipped seat 	<ol style="list-style-type: none"> 1. Inspect connections for air leaks 2. Disassemble and clean 3. Inspect and adjust 4. Inspect and replace
Gun will not shut off	<ol style="list-style-type: none"> 1. Worn or broken needle & seat 2. Needle assembly out of adjustment 3. Dirty gun 	<ol style="list-style-type: none"> 1. Replace 2. Adjust 3. Clean
Gun does not spray	<ol style="list-style-type: none"> 1. No paint 2. Plugged filter or tip 3. Broken needle in gun 	<ol style="list-style-type: none"> 1. Check fluid supply 2. Clean 3. Replace

AIRLESS TIP SELECTION

Tips are selected by the orifice size and fan width. The proper selection is determined by the fan width required for a specific job and by the orifice size that will supply the desired amount of fluid and accomplish proper atomization.

For light viscosity fluids, smaller orifice tips generally are desired. For heavier viscosity materials, larger orifice tips are preferred. Please refer to the chart below.





Note: do not exceed the pump's recommended tip size.

The following chart indicates the most common sizes and the appropriate materials to be sprayed.

.011 - .013	Lacquers & Stains	100 Mesh Filter
.015 - .019	Oil & Latex	50 Mesh Filter
.021 - .026	Heavy Bodied Latex & Blockfillers	5 Mesh Filter

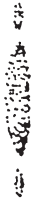
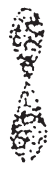
Fan widths measuring 8" to 12" (20 to 30 cm) are most preferred because they offer more control while spraying and are less likely to plug.

TROUBLESHOOTING GUIDE: SPRAY PATTERNS

CONDITION	POSSIBLE CAUSE	CORRECTION
<p>TAILS</p> 	Inadequate fluid delivery.	<p>Fluid not atomizing correctly. Increase fluid pressure. Change to smaller tip orifice size. Reduce fluid viscosity. Reduce hose length.</p> <p>Clean gun and filter(s). Reduce number of guns using pump.</p>
<p>HOUR GLASS</p> 	Inadequate fluid delivery.	Same as above.
<p>DISTORTED</p> 	Plugged or worn nozzle tip.	Clean or replace nozzle tip.
<p>PATTERN EXPANDING & CONTRACTING (SURGE)</p> 	<p>Suction leak.</p> <p>Pulsating fluid delivery</p>	<p>Inspect for suction hose leak.</p> <p>Change to a smaller tip orifice size.</p> <p>Install pulsation dampener in system or drain existing one. Reduce number of guns using pump.</p> <p>Remove restrictions in system; clean tip screen if filter is used.</p>
<p>ROUND PATTERN</p> 	<p>Worn tip.</p> <p>Fluid too heavy for tip.</p>	<p>Replace tip.</p> <p>Increase pressure. Thin material. Change nozzle tip.</p>

TROUBLESHOOTING GUIDE HYDRAULIC MOTORS

CONDITION	POSSIBLE CAUSE	CORRECTION
Oil motor stalls at bottom. (No unusual heat problems.)	Fluid pump piston seat unthreaded. Valve sticking or oil motor trip rod shifter assembly separated.	If connecting rod is okay, remove cylinder head plug and pop valve down. Replace plug and start machine. If machine cycles up and stops at bottom again, then problem is piston seat on fluid pump. Check piston seat. Repair or replace as necessary. If piston seat is okay and problem does not change, check oil motor. Remove valve and check for scratches and rough movement when sliding it up and down. Replace valve and spool in this condition. Check trip rod for possible separation. and spool in this condition. Check trip rod for possible separation.
Oil motor stalls at top. (No unusual heat problems)	Valve sticking. Broken spring retainer (valve rod assembly) Broken spring or valve rod. Air in hydraulic motor. Air in fluid pump.	Remove valve and check for scratches and rough movement when sliding it up and down. Replace valve and spool in this condition. Replace valve rod assembly. Replace valve rod assembly. Reset Valve. Purge Air, generally accomplished by low pressure cycling of moter/pump assembly for 5 - 10 minutes. Check for causes of air introduction. <ul style="list-style-type: none"> • Loose fittings in tank. • Loose fittings on hydraulic pump. • Loose hose connections. • Low oil in reservoir. Stall at top can occur randomly when fluid pump picks up air. Reset valve. Avoid air in the fluid pump.
Low pressure (okay on down stroke, sluggish on up.stroke - high heat) Note: Engine labors on upstroke, idles back at stall on the down stroke.	Blown piston seal. Cracked piston.	Before dismantling oil motor, start machine. With pump cycling under pressure, touch the hydraulic cylinder and the head to see if cylinder or head gets hotter. This will help determine if piston seal is blown or piston nut is broken. If heat is on the head, check the O-Rings on spool valve. Dismantle oil motor and check piston seals cylinder bore and piston nut. Pay special attention to piston nut. It can be cracked and not show externally.
Low pressure (both strokes - high heat) Note: Engine labors at stall on both strokes	Blown center O-Rings on spool valve. Bad hydraulic pump.	Before dismantling oil motor, start machine. With pump cycling under pressure, touch the head to see if the head becomes hotter. This will help determine if center O-Ring is blown on spool valve. If hot, remove and replace O-Ring. Replace hydraulic pump.

TROUBLESHOOTING GUIDE FLUID SECTIONS

CONDITION	POSSIBLE CAUSE	CORRECTION
Pump delivers on upstroke only or goes up slowly and down fast. (Commonly called downstroke dive.)	Lower foot valve ball is not seating due to trash or wear. Material too viscous to syphon. Air leaking in on syphon side or damaged syphon hose. Syphon may be too small for heavy material	Remove foot valve assembly. Clean and inspect. Test foot valve by filling with water; if ball fails to seal the seat, replace ball. Thin material - contact manufacturer for proper thinning procedures. Tighten all connections between pump and paint container. If damaged, replace. Switch to larger diameter syphon set.
Pump delivers on down stroke only .or goes up fast and down slowly	Upper ball is not seating due to trash or wear. Lower packing set is worn.	Check upper seat and ball with water. If ball fails to seal seat, replace. Replace packing set if worn.
Pump moves up and down fast, delivering material.	Material container is empty or material is too thick to flow through syphon hose Bottom ball stuck to foot valve seat. Syphon hose is kinked or loose.	Refill with new material. If too thick, remove syphon hose and immerse pump or not add thinner to material. Change to bigger syphonset. Open bleed valve to . remove air and restart pump. Remove foot valve. Clean ball and seat. Straighten.
Pump moves up and down slowly when spray gun is shut off.	Loose connections. Bleed valve is open partially or bleed valve is worn. Lower packing seat is worn. Upper and/or lower ball not seating.	Check all connections between pump and gun. Tighten as necessary. If material is flowing from bleed hose, close bleed valve or replace if necessary. Should none of the above be evident, replace lower packing. Reseat balls by cleaning.
Not enough fluid pressure at gun.	Spray tip is worn. Outlet filter or gun filter is clogged Low voltage and/or inadequate amprage. Hose size or length is too small or too long.	Replace. Clean or replace filter. Check electrical service. Correct as required. Increase hose size to minimize pressure drop through hose and/or reduce hose length.
Pump chatters on up or down stroke	Solvent has caused upper packing to swell.	Replace packing.

PowrTwin 4500™ Major Components

GAS MODELS

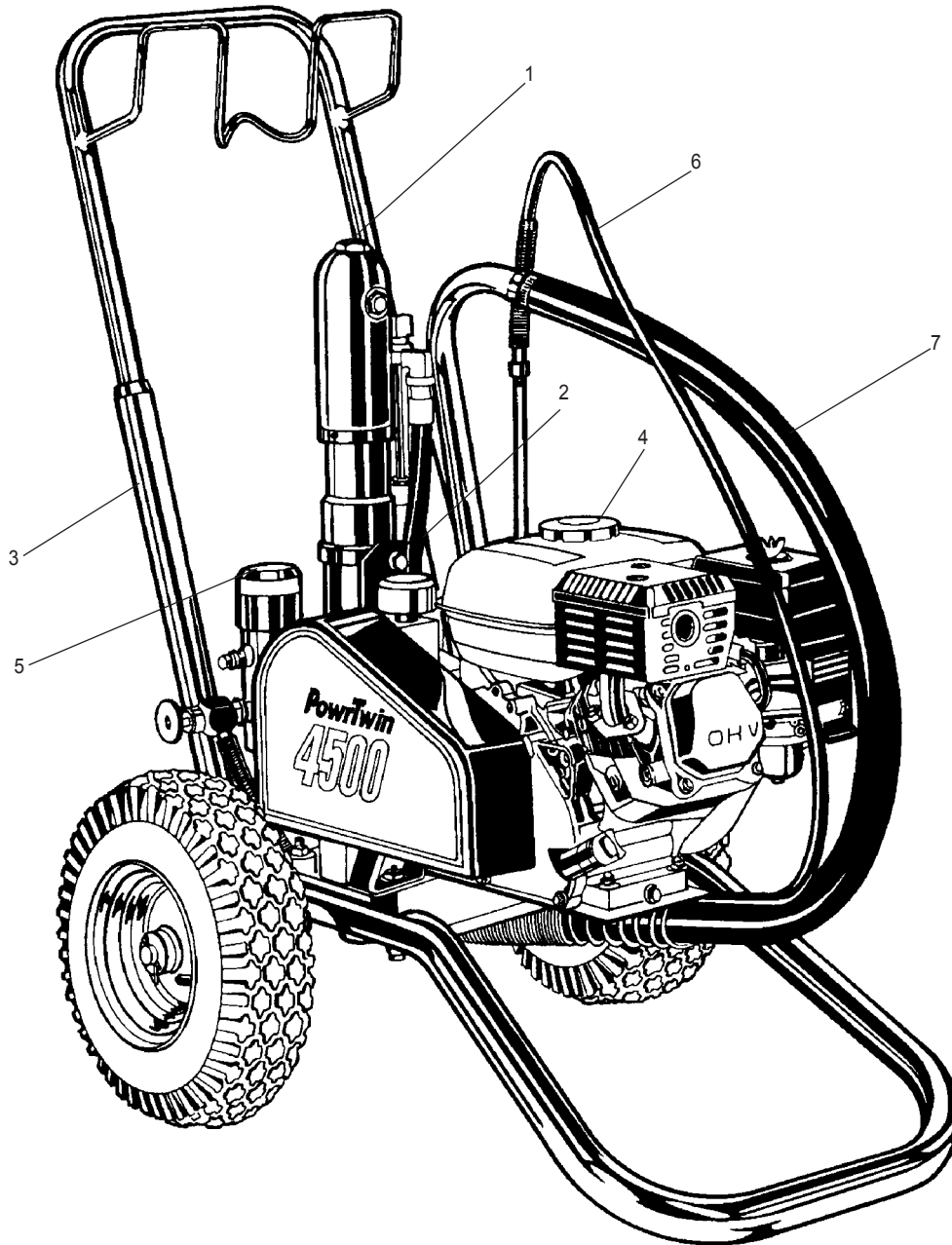

GAS MODELS

ITEM NO.	PART NO.	DESCRIPTION	HONDA 448-650	CSA HONDA 448-658
1	235-107	Motor/Pump Assembly	1	1
2	-	Hydraulic System	1	1
3	-	Cart Assembly	1	1
4	506-112	Convertokit, 4 HP, Honda, Gasoline	1	1
5	920-559	Filter Assembly, Outlet Manifold	1	1
6	840-211	Bleed Line Assembly w/Valve	1	1
7	103-826	Syphon Hose Assembly, 1" x 4-1/2"	1	1

PowrTwin 4500™ Gas Convertokits

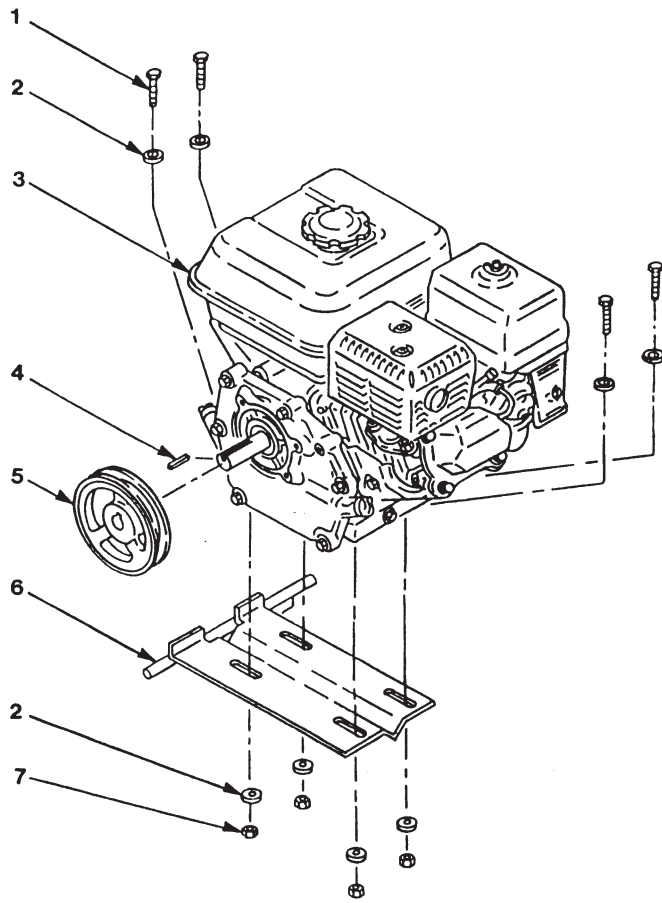

506-112 GAS CONVERTOKIT

ITEM NO.	PART NO.	DESCRIPTION	QUANTITY
1	860-552	Screw	4
2	860-004	Washer, Flat	8
3	980-332	Engine, Gas 4 HP, Honda	1
4	980-307	Key	1
5	448-221	Pulley	1
6	448-336	Mounting Plate, Gas Eng.	1
7	860-502	Nut, Stop	1
8	424-285	Belt, "V" (Not Illustrated)	*

*Not part of this assembly

PowrTwin 4500™ DC - Electric Convertokits

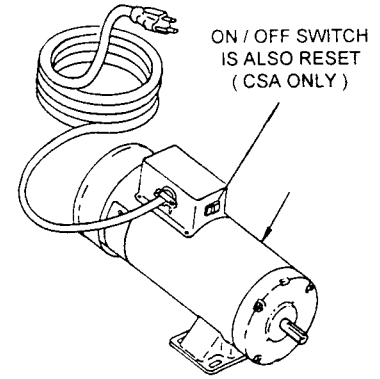
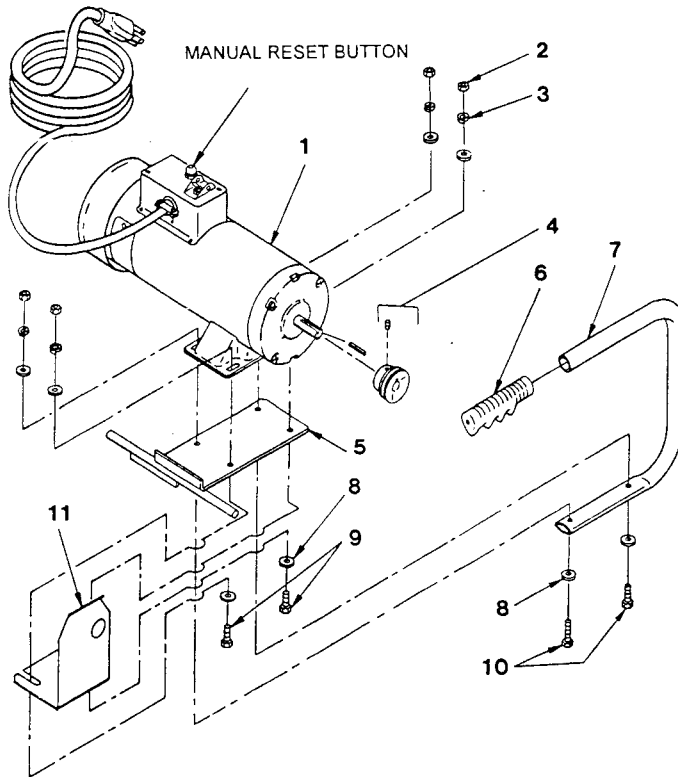

CSA approved motor

DC - ELECTRIC CONVERTOKITS

ITEM NO.	PART NO.	DESCRIPTION	506-217	506-204	506-214
			115 V	CSA 115 V	220 V
			QTY	QTY	QTY
1	978-350	Motor, DC-Electric, 2 HP, 50 / 60 Hz, 115 V	1		
1a	978-351	Motor, DC-Electric, 2 HP, 50 / 60 Hz, 220 V			1
1b	978-384	Motor, DC-Electric, 2 HP, 50 / 60 Hz, 115 V CSA approved		1	
2	860-501	Nut Stop	4	4	4
3	860-002	Washer, Lock	4	4	4
4	977-227	Pulley	1	1	1
5	448-337	Mount, Plate	1	1	1
6	590-068	Grip, Handle	1	1	1
7	335-017	Handle	1	1	1
8	860-004	Washer, Flat	8	8	8
9	860-535	Screw	2	2	2
10	860-552	Screw	2	2	2
11	449-192	Shield, Motor Shaft		1	
12	747-951	Decal Identification Kit (FRENCH)		1	
13	424-285	Belt (Not illustrated)	*	*	*

*Not part of this assembly

PowrTwin 4500™ Electric Convertokits - Service Instructions

WARNING: Before servicing the electric motor, follow the Pressure Relief Procedure on Page 10. Once you have completed this procedure, unplug the power supply cord. Failure to reduce pressure can result in serious injury. Observe all warnings.

Note: Brushes should be replaced when they are worn to less than 1/2 inch. Check and replace both brushes at the same time. Brush Repair Kit, Part No. 978-050, consists of: 2 brushes, 2 springs, and 2 clips.

1. Remove both inspection covers on Motor. See Figure 1.

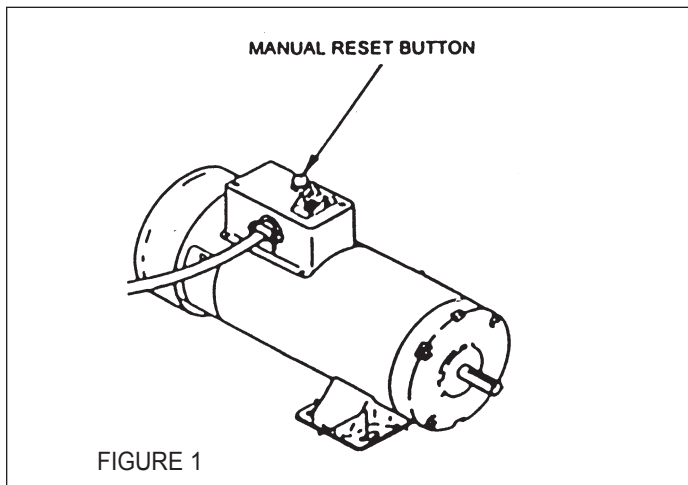

2. Push in the Spring Clip to unhook it and then pull it out. See Figure 2.

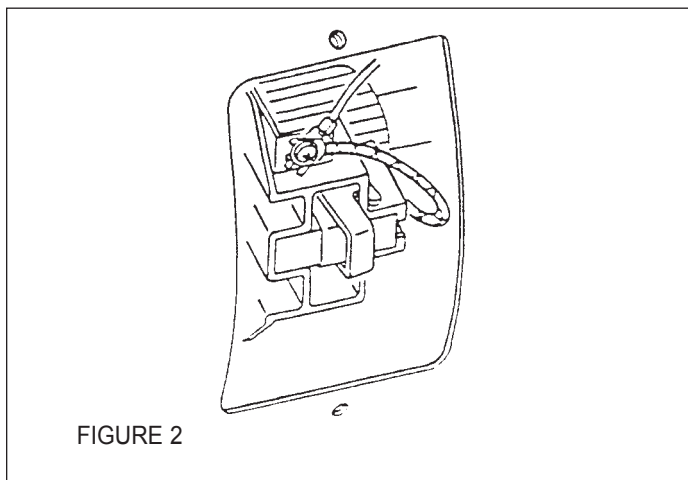

3. Loosen the terminal screw. Pull the brush lead away, but leave the motor lead in place. Remove the brush and spring. See Figure 3.

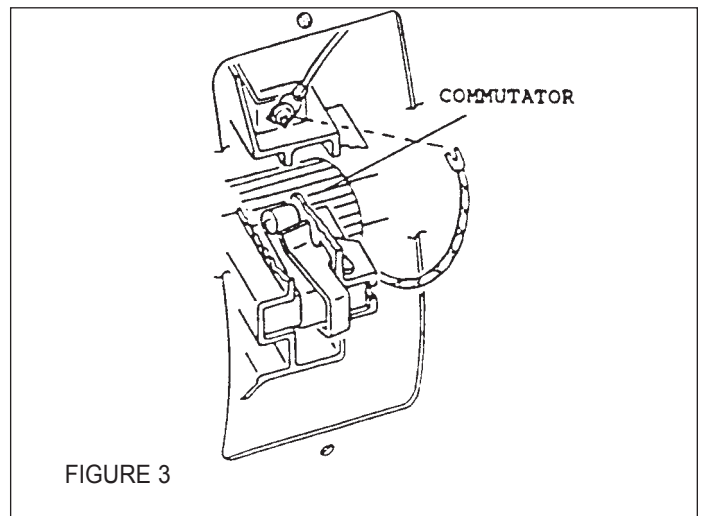

4. Inspect the commutator for burning, excessive pitting or gouging. A black color on the commutator is normal.

5. Install the new brush so its lead slides in the long slot of the brush holder. Push the terminal under the terminal screw washer. Insure the motor lead is still connected at the screw. Tighten the

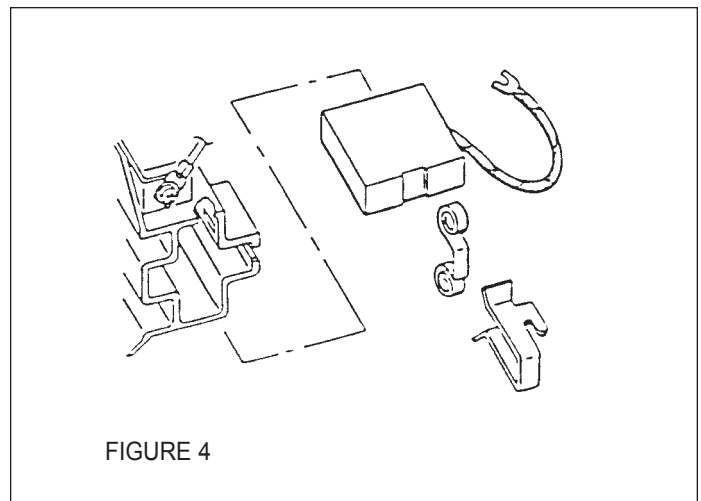

screw. See Figure 4.

6. Place the spring on the brush as shown in Figure 4. Push in and hook the spring clip. Repeat this procedure for the other side. Reinstall the inspection covers.

PowrTwin 4500™ Cart Assembly

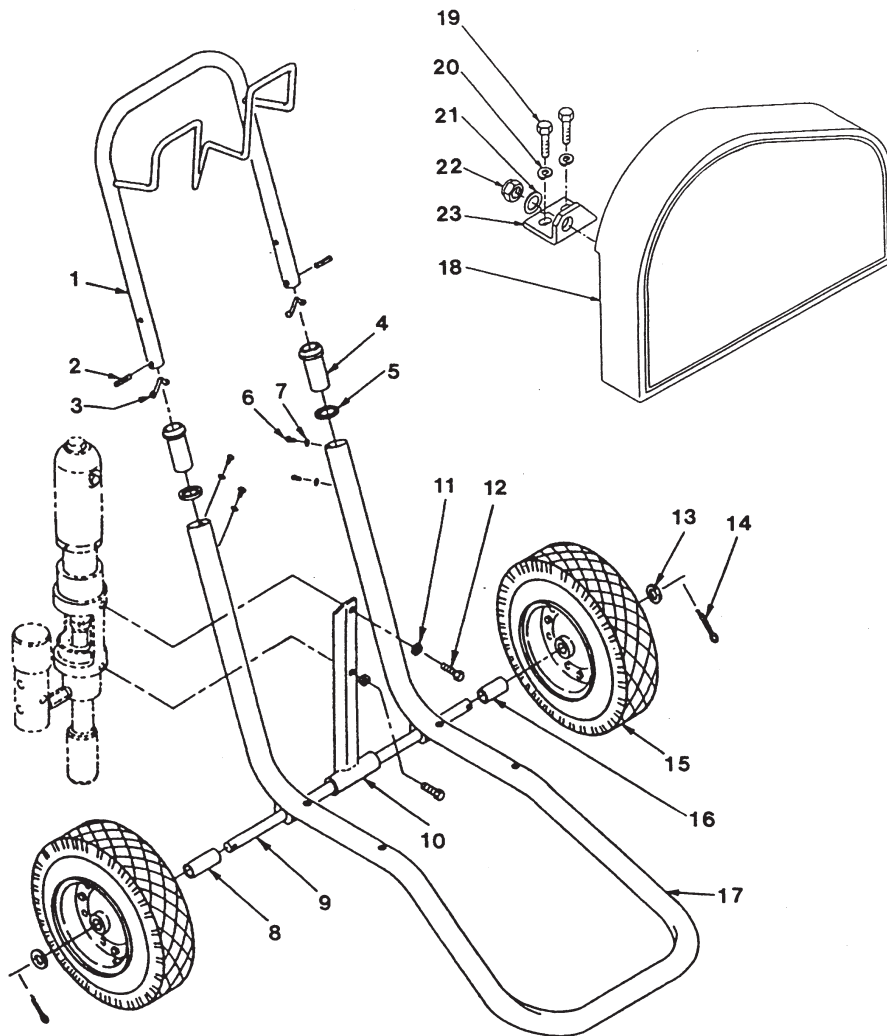

CART ASSEMBLY

CART ASSEMBLY (Continued)

ITEM NO.	PART NO.	DESCRIPTION	QUANTITY	ITEM NO.	PART NO.	DESCRIPTION	QUANTITY
1	590-502	Handle	1	13	870-004	Washer	2
2	590-508	Roll Pin	2	14	570-010	Key, Cotter	2
3	590-507	Snap Button	2	15	670-109	Wheel	2
4	590-504	Sleeve	2	16	449-145	Spacer	1
5	590-506	Washer	2	17	590-525	Frame	1
6	856-921	Screw	4	18	448-203	Belt Guard Assembly	1
7	856-002	Washer	1	19	858-636	Screw (2)	
8	449-120	Spacer	1	20	858-002	Washer, Lock (2)	
9	590-503	Axle	1	21	862-001	Washer, Flat (1)	
10	449-102	Motor/Pump Bracket	1	22	862-411	Nut (1)	
11	862-002	Washer, Lock	2	23	449-187	Clip (1)	
12	862-444	Screw	2				

PowrTwin 4500™ Hydraulic System

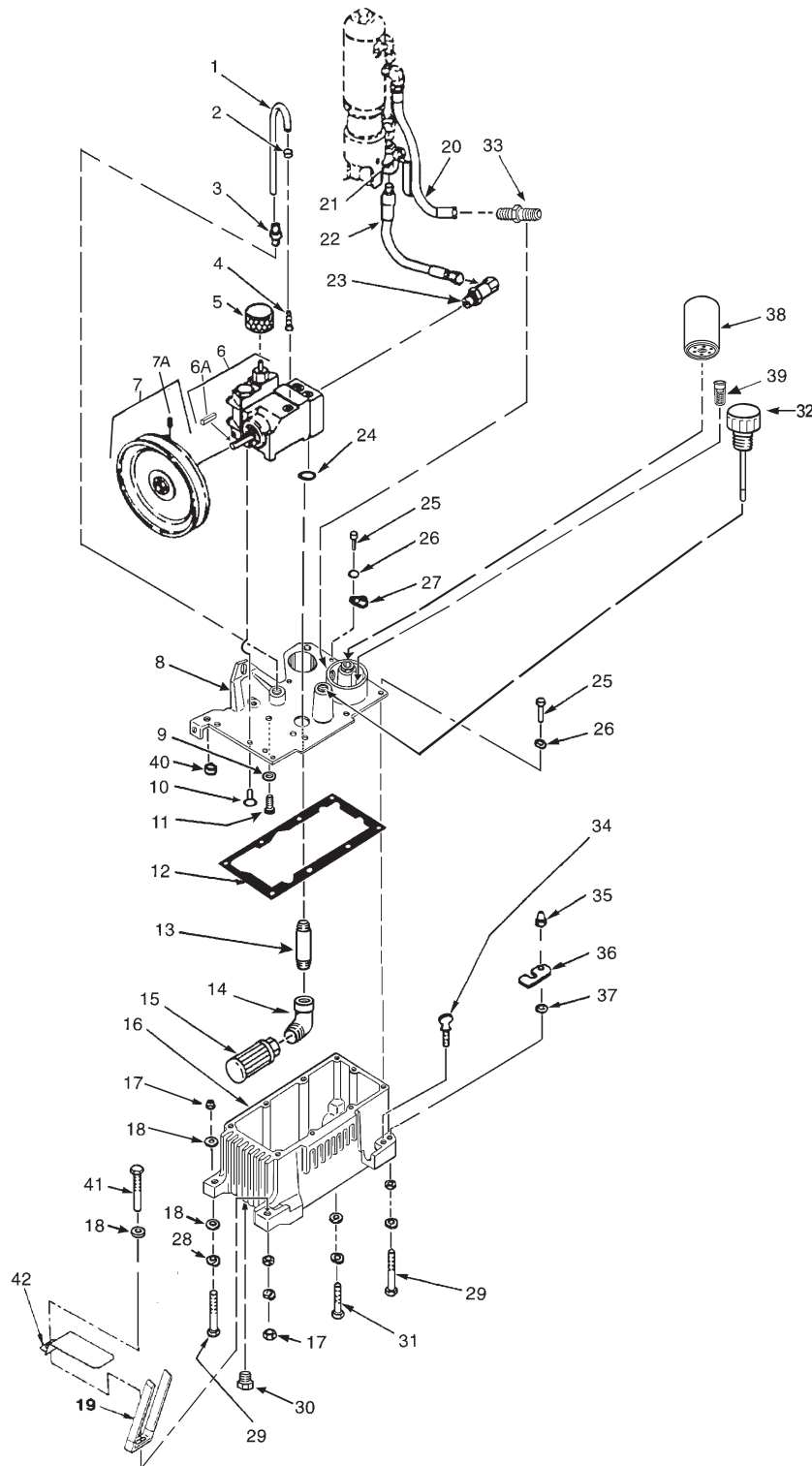

ITEM NO.	PART NO.	DESCRIPTION	QUANTITY
1	420-250	Tubing, UVØØ	1
2	448-126	Hose Clamp	1
3	431-042	Connector, Tube	1
4	192-228	Elbow	1
5	448-243	Adjustment Knob	1
6	448-500	Pump, Hydraulic	1
6A	448-492	Key, Pump (.125 x .125 x 1)	1
7	448-237	Pulley/Fan Assembly	1
7A	860-520	Set-Screw	1
8	449-604	Cover, Tank	1
9	859-001	Washer	2
10	858-621	Screw, Socket	2
11	858-624	Screw	2
12	449-605	Gasket, Tank	1
13	112-208	Nipple	1
14	472-500	Elbow, Street	1
15	448-208	Screen, Inlet	1
16	449-602	Tank, Hydraulic	1
17	862-411	Nut, Flex Lock	2
18	862-001	Washer, Flat	6
19	448-232	Brace, Belt Guard	1
20	448-213	Hose Assembly, Return	1
21	941-555	Valve, Ball	1
22	448-235	Hose Assembly, Pressure	1
23	192-050	Elbow	1
24	325-031	O-Ring	1
25	858-636	Screw, HH	8
26	858-002	Washer, Lock	10
27	101-205	Lug, Ground	1
28	862-002	Washer, Lock	4
29	862-493	Screw, HH	2
30	227-027	Plug	1
31	862-480	Screw, HH	1
32	335-010	Cap, Filler w/ Dipstick	1
33	449-621	Fitting	1
34	862-438	Screw, Thumb	1
35	862-402	Nut, Acorn	1
36	449-107	Retainer, Mounting Plate	1
37	449-135	Spacer	1
38	449-610	Filter, Hydraulic	1
39	449-609	Hydraulic By-Pass	1
40	858-609	Nut, Clinch	1
41	862-496	Bolt, Tap	1
42	448-242	Shield (for models 448-657 and 448-658 ONLY)	1

TORQUE AND SEALANT GUIDE

ITEM NO.	INSTRUCTIONS
3	Use Hydraulic Sealant
7	Use Blue Loctite on threads
10	Use Blue Loctite on threads
10	Torque to 8 FT/LBS (117 N/m)
11	Torque to 8 FT/LBS (117 N/m)
13	Use Hydraulic Sealant
14	Use Hydraulic Sealant
15	Use Hydraulic Sealant
25	Torque to 20 FT/LBS (293 N/m)
29	Torque to 15 FT/LBS (219 N/m)
31	Torque to 15 FT/LBS (219 N/m)
33	Use Hydraulic Sealant
41	Torque to 15 FT/LBS (219 N/m)

PowrTwin 4500™ Hydraulic Motor

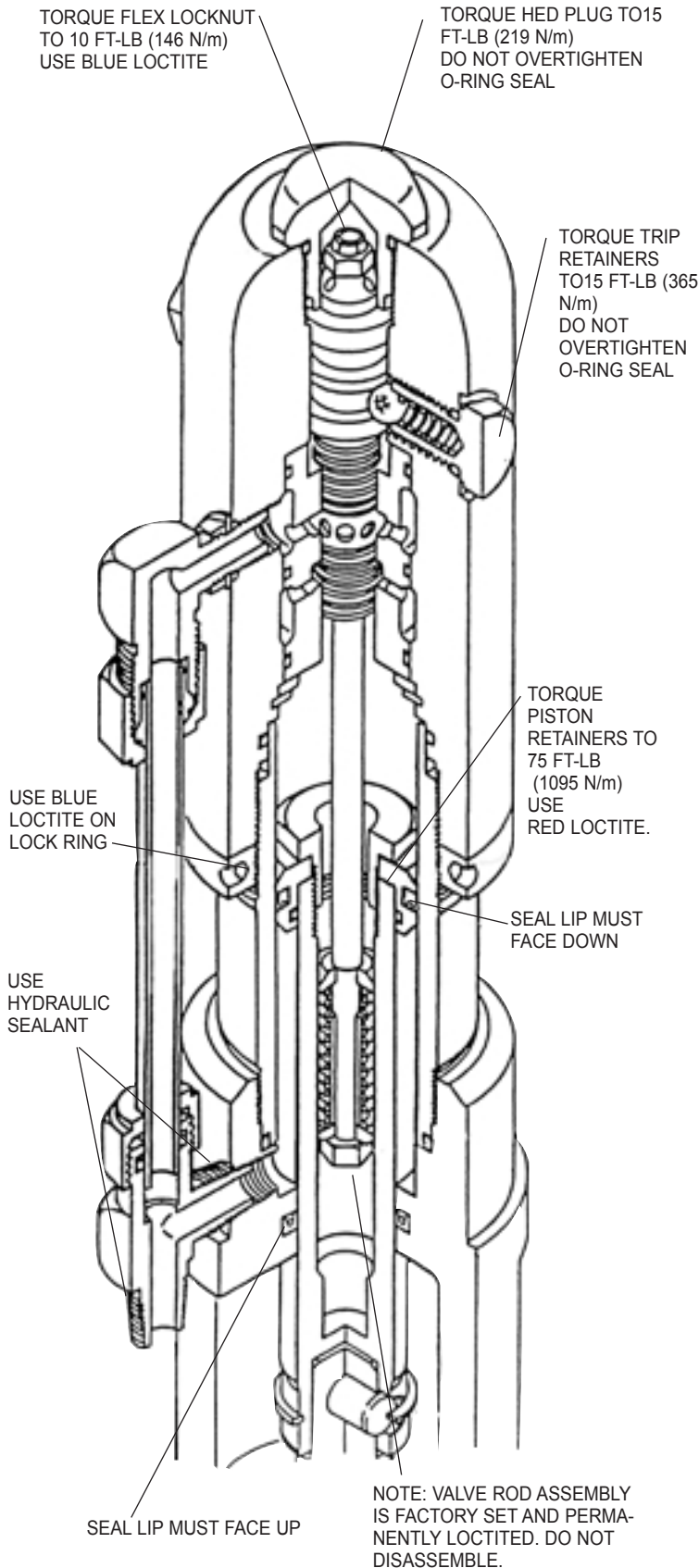

Hydraulic Motor Service Instructions

DISASSEMBLY

1. Disconnect the high pressure hose line from the Elbow (23) on the back of the rotary pump. See Page 21 of the Hydraulic System.
2. Remove the two mounting - bolts (12), and Lock Washers (11) which attach the motor pump assembly to the frame. See Cart Assembly, Page 20.
3. Place the motor pump assembly in a vise, holding it securely by the Pump Block (25).

DISASSEMBLY OF HYDRAULIC MOTOR

Disassembly of the hydraulic motor must be carried out in an absolutely clean area. Any dust or metallic particles left in the motor or entering it on reassembly may damage the critical parts and affect its service life and warranty. If the hydraulic motor is operable, start the machine and place the Piston Rod (21) in its top position.

1. Remove Cylinder Head Plug (7).
2. Loosen Lock Ring (22) with a spanner wrench and unthread tube retaining nut on Tee (27). Lift Retaining Nut (27) up. Insert Screwdriver flat tip into split on Retaining Collar (27). Twist slightly to raise up approximately 1/2". Loosen Tube Retaining Nut on Elbow (15). Slide nut down. Push Motor Tube (26) into Tee (27) far enough to clear Elbow (15). Slowly unthread Head Assembly (11) and lift it just high enough above the Cylinder (23) to reach the Valve Rod (20) with vise grip pliers.
3. The Piston Rod (21) should be near the top of its stroke for disassembly. It may be necessary to use a wood or nylon driver to push the piston rod up to its top position.
4. Grip the Valve Rod securely with vise grip pliers and then remove the FlexLoc Nut (9) from the top of the Valve Rod Assembly (20). Be careful that Spool (5) does not fall. The Head (11) can now be lifted off. Unthread the Cylinder (23) from the Motor Pump Block (25). Note: An extra Lock Ring (22) can be used to jam the two Lock Rings (22) together on the cylinder and a pipe wrench can now be used to unthread the Cylinder (23) from the Pump Block (25).
5. To remove Connecting Rod Pin (2), slide the Ring up with a small screwdriver. Then push the Connecting Rod Pin out. See the illustration on Page 31.
6. Remove the Piston Rod Assembly from the Pump Block (25).
7. Remove Seal (24), being extremely careful not to scratch the seal groove in the Motor Block (25).
8. Unthread Piston Retainer Screw (16) from Piston Rod (21) by holding piston rod firmly at its base in a vise. Check screw for damage.
9. Remove Piston (17) and lift out Valve Rod Assembly (20).
10. Remove Piston Seal (18) and O-Ring (19).
11. Remove Trip Retainers (1), Trip Springs (3), and Balls (4) from Cylinder Head (11). Remove O-Rings (2) from Trip Retainers (1).
12. Remove Snap Ring (14) and Sleeve Retainer (13) and then gently tap Spool and Sleeve Set (5) out of Cylinder Head (11). Remove O-Rings (6) from valve sleeve.
13. Inspect Piston Rod (21) and Cylinder (23) for wear, scratches, and dents. Replace if damaged.
14. Inspect Spool Valve (5) for wear. Replace if necessary. Spool Valve should move smoothly and freely with no force by holding in a vertical position. If it does not, it can cause the motor to stall.

Reassembly of this motor should be carried out in a clean, dust free area only. It is recommended that a full Motor Service kit, Minor be on hand. All parts should be inspected for absolute cleanliness. Any particles of dust or metal will affect service life of the sealed motor and hydraulic system.

PowrTwin 4500™ Hydraulic Motor

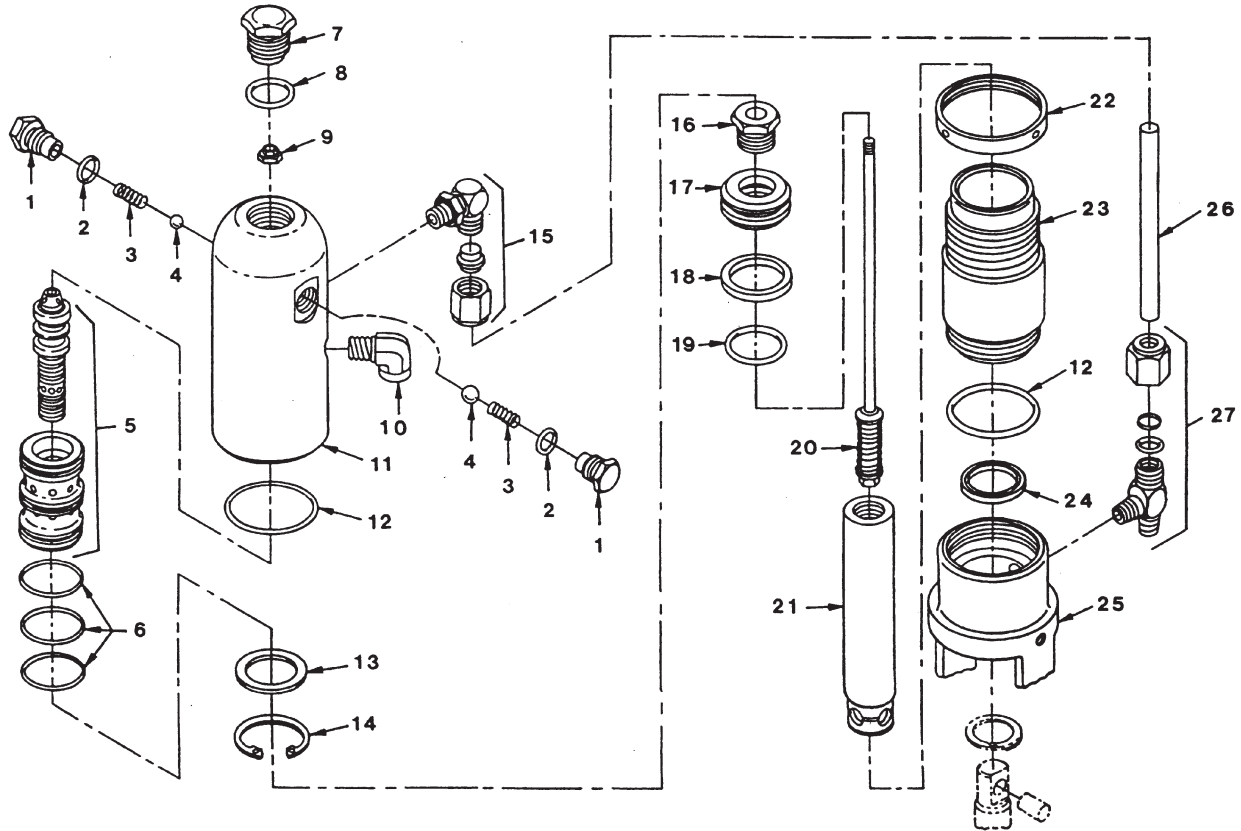

ITEM NO.	PART NO.	DESCRIPTION	QUANTITY
1	235-018	Retainer, Trip	2
2	141-007	O-Ring	2
3	325-005	Spring, Trip	2
4	569-016	Ball, SS	2
5	441-908	Spool / Sleeve Set	1
6	441-152	O-Ring	3
7	235-030	Plug, Cylinder Head	1
8	441-217	O-Ring	1
9	858-811	Nut, Flex Lock	1
10	818-002	Elbow, Street, 90°	1
11	235-112	Cylinder Head	1
12	431-032	O-Ring	2
13	431-053	Retainer, Sleeve	1
14	431-054	Ring, Retainer	1
15	192-000	Elbow	1
16	235-022	Screw, Piston Retainer	1
17	235-014	Piston	1
18	235-027	Seal, Piston	1
19	235-026	O-Ring	1
20	235-021	Valve Rod Assembly	1
21	235-948	Piston Rod	1
22	235-001	Ring, Lock	1
23	235-007	Cylinder	1
24	235-028	Seal, Rod	1
25	235-929	Motor Pump Block	1
26	235-023	Tube, Motor	1
27	197-031	Tee	1
27a	431-019	O-Ring	1

REASSEMBLY OF HYDRAULIC MOTOR

1. Replace O-Rings (6) onto Sleeve (5) after lubricating these parts with oil.

CAUTION: Do not use Piston Lube pump packing lubricant. It is a

solvent and will severely damage seals and O-Rings of the hydraulic motor.

Gently push the Spool Sleeve Set (5) into Cylinder Head (11) using a nylon driver and a rubber mallet until sleeve has reached its full depth. Do not use any other type of tool that might leave particles or residue.

2. Install O-Rings (2) on Trip Retainers (1). Install the Trip Retainer Balls (4) followed by Springs (3) which, when installed, will hold the Spool (5) in proper place for assembly.
3. Install Sleeve Retainer (13) followed by Snap Ring (14) in Cylinder Head (11) which will hold valve sleeve in place. Install O-Ring (12) in O-Ring groove of cylinder head.
4. Replace Lower Seal (24) in Motor Block (25). Be sure the open portion of the seal is facing upward (V). This seal requires no special tool.
5. Place Piston Rod (21) in vise. Inspect Valve Rod Assembly (20) for any damage. Make sure the lock nut at the bottom of the Valve Rod Assembly (20) is secure. DO NOT remove. Then place into Piston Rod (21) as illustrated. Install O-Ring (19), lubricating it well and replacing Piston (17) onto Piston Rod (21). Put one drop of blue Loctite on the Piston Retainer Screw (16). Tighten piston retainer screw until piston is locked into place. Check Valve Rod Assembly (20) for normal spring action at this time.
6. Install Piston Seal (18) with lips facing downward. Carefully install The Piston Seal (18). Expand the ring and stretch it sufficiently for installation.
7. With Motor Pump Block (25) still in vise, install Lower Seal (24) by pushing it towards its groove with a properly sized blunt rod. Then complete installation with the fingers. No tool is necessary. Do not twist the seal.
8. Prelubricate the piston and valve rod assembly with Coolflo™ Hydraulic Fluid, Part No. 430-361. Install Piston Rod (21) into

PowrTwin 4500™ Fluid Pump

- Motor Pump Block (25) with a gently pushing and rotating motion to work the Piston Rod (21) in through the Seal (24).
9. Replace the Connecting Rod Pin and Retainer Ring. See illustration below.
10. Install O-Ring (12) on cylinder wall. Lubricate ring and inner wall. With Piston Rod held firmly, the cylinder should be gently driven over the piston seal with a rubber mallet. Tightly thread the cylinder into Motor Pump Block (25).
11. Raise Piston Rod (21) to top position and thread Lock Ring (22) all the way up on upper threads of Cylinder (23).
12. Pull Valve Rod Assembly (20) up as far as it will travel and grasp it with vise grip pliers. Then install Cylinder Head (11), already assembled, over valve rod until the top threads of the valve rod pass through the top of the Spool (5). The valve rod threads must be clean and free of oil. Place one drop of blue Loctite on threads of Flex Lock Nut (9) and thread nut onto valve rod to full tight position (do not overtighten) while holding valve rod below with vise grip pliers.
13. Thread Cylinder Head (11) down onto the Cylinder (23) and then back off just enough to reassemble hydraulic fittings and Motor Tube (26). Tighten lock ring with spanner wrench to hold cylinder head in position.
14. The Tee Assembly (27) and the Elbow (15) uses an O-Ring (27a) to seal on the O.D. of the Motor Tube (26). For installation of Elbow (15) see Page 32. The O.D. of the Motor Tube (26) should be free of scratches or sharp edges. The lock nuts on these fittings should be hand tightened, then wrench tightened another half turn.
15. Install O-Ring (8) onto Cylinder Head Plug (7). Tighten.

235-050 MOTOR SERVICE KIT, MINOR

ITEM NO.	PART NO.	DESCRIPTION	QUANTITY
2	141-007	O-Ring	2
3	325-005	Spring, Trip	2
4	569-016	Ball, SS	2
6	441-152	O-Ring	3
8	441-217	O-Ring	1
9	858-811	Nut, Flex Lock	1
12	431-032	O-Ring	2
18	235-027	Seal, Piston	1
19	235-026	O-Ring	1
24	235-028	Seal, Rod	1

CONNECTING PIN ARRANGEMENT

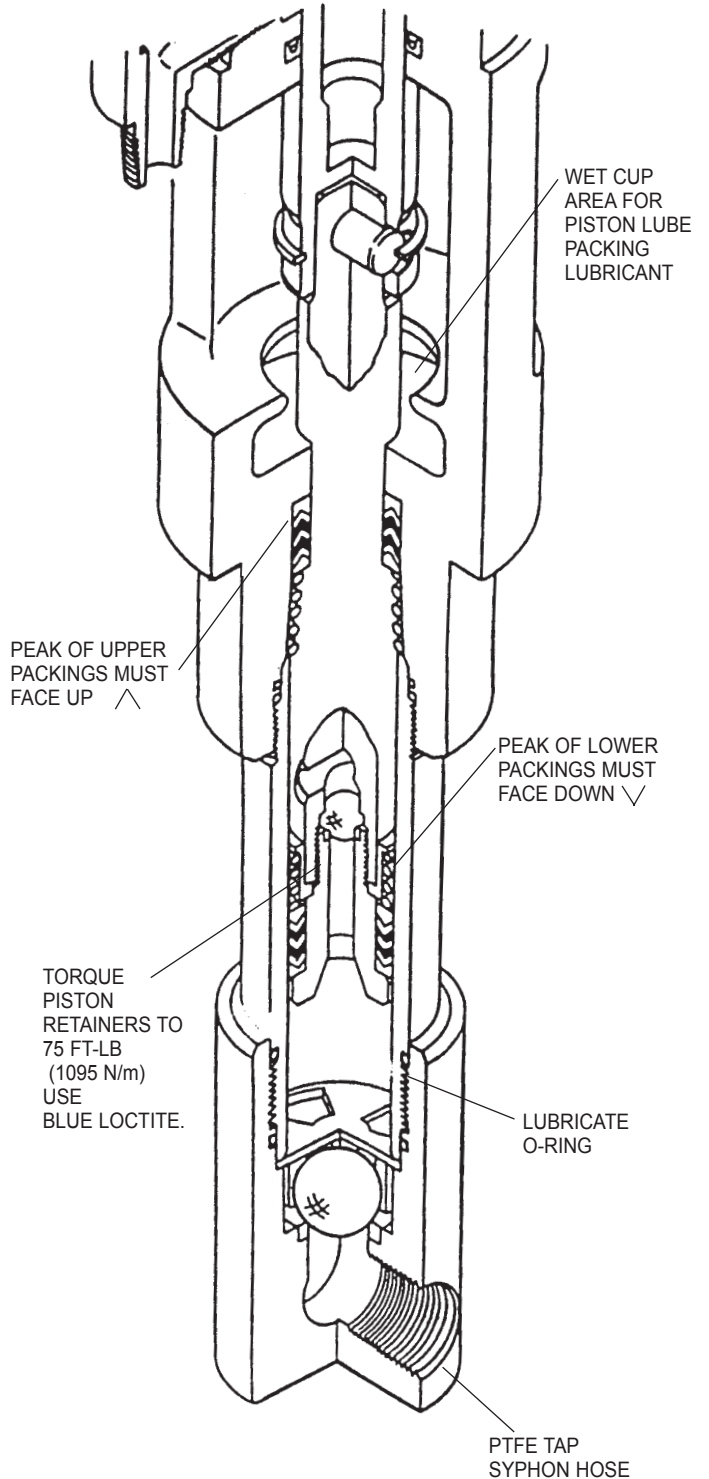
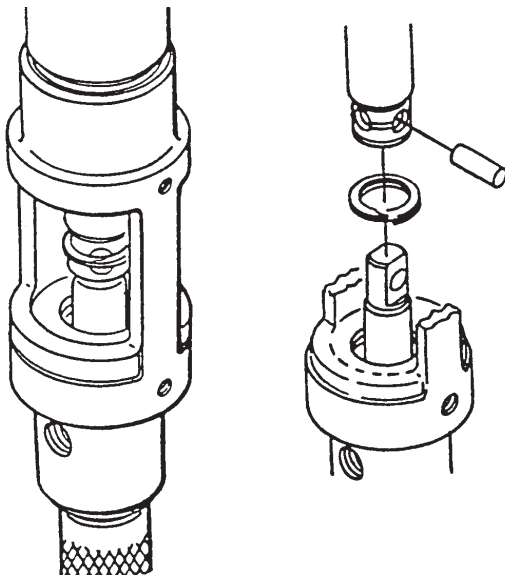

PowrTwin 4500™ Fluid Pump Service Instructions

IMPORTANT: USE OF NON-SPEEFLO MANUFACTURED SERVICE PARTS MAY VOID WARRANTY. ASK FOR ORIGINAL PARTS MADE BY SPEEFLO FOR BEST SERVICES. The 143 Series Pump should receive a routine servicing after approximately 1,000 hours of use. Earlier servicing is required if there is excessive leakage from the top packing or if pump strokes become faster on one stroke or the other. The use of **Titan/Speeflo Piston Lube, Part # 700-925**, is recommended as an upper packing lubricant. **DO NOT SUBSTITUTE OIL, WATER, OR SOLVENT** for an upper packing lubricant.

DISASSEMBLY

1. Remove Syphon Assembly. Unthread Foot Valve (15) and Pump Cylinder (11) with strap wrench.
2. Slide the Retainer Ring (1) up with a small screwdriver, then push the Connecting Rod Pin (2) out.
3. Pull Displacement Rod (6) through lower cavity of Pump Block.
4. Remove Pump Block PTFE O-Ring (3), Packing Spring (5), and Packing Set (4).
5. Hold Displacement Rod (6) in vise by the flats at top of rod and remove Piston Seat (10) with wrench while holding displacement rod horizontal with wooden support if necessary. Remove Piston Ball (9), Packing Set (4), Lower Packing Spring (8) and Spring Retainer (7).
6. Remove Ball Stop Cage (13), PTFE O-Ring (3) and Foot Valve Ball (14).
7. Replace Connecting Rod Pin (2) and Retainer Ring (1).
8. Remove O-Ring (12) from Pump Cylinder (11)

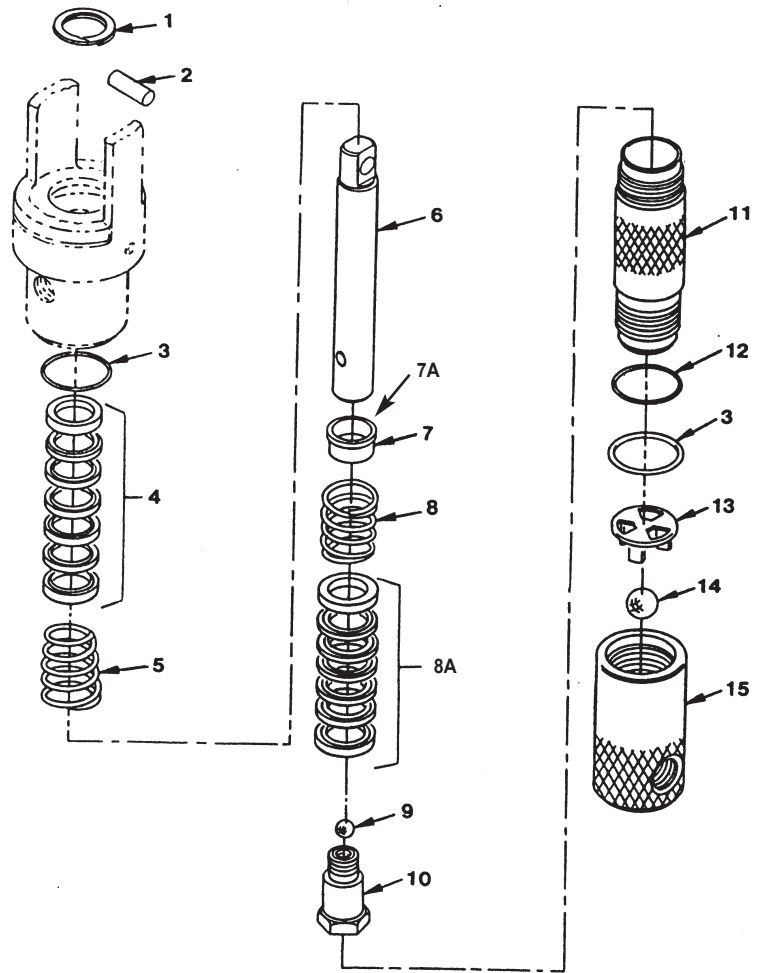

REASSEMBLY

NOTE: USE PTFE TAPE ON ALL THREADED PIPE CONNECTIONS.

1. Install Pump Cylinder O-Ring (3) and (12) into O-Ring groove of Pump Cylinder (11) and O-Ring (3) into Pump Block.
2. Place O-Ring (3) into Foot Valve (15).
3. Place Foot Valve Ball (14) in Foot Valve (15) and install Ball Stop Cage (13).
4. Connect Foot Valve (15) to Pump Cylinder (11). Place Packing Set (4) over Piston Seat (10). **CAUTION:** Peak of V packing must point down toward Foot Valve (15). Place Piston Ball (9) on Piston Seat (10). Follow with Lower Packing Spring (8) and Spring Retainer (7). Thread Displacement Rod (6) onto Piston Seat (10) tightly using red Loctite.
5. Insert Packing Set (4) into Pump Block. **CAUTION:** Peak of "V" packing must point up toward motor. Place Upper Packing Spring (5) (small end toward packing) into the lower cavity of Pump Block behind Upper Packing Set (4).
6. Insert Displacement Rod (6) through lower cavity of Pump Block. Rotate Displacement Rod until holes in Displacement Rod and hydraulic piston rod line up.
7. Push Cylinder (11) over Packings (4) and connect to Pump Block. **CAUTION:** O-Ring (3), and Packing Spring (5) must be in place before connecting Cylinder (11) to Pump Block.
8. Attach syphon assembly.

ITEM NO.	PART NO.	DESCRIPTION	QUANTITY
*	235-923	Pump Block	1
		*(See item No.m25 On Hydraulic Motor Assembly)	
1	143-019	Retainer Ring	1
2	107-003	Connector Rod Pin	1
3	106-015	O-Ring, PTFE	2
4	106-002	Packing Set, Leather/UHMWPE	1
5	106-005	Packing Spring, SS	1
6	108-021	Displacement Rod	1
7	106-116	Sleeve	1
7A	106-001	Spring Retainer	1
8	106-016	Packing Spring, SS	1
8A	106-002	Packing Set, Leather/UHMWPE	1
9	569-021	Ball, SS	1
10	106-011	Piston, Seat	1
11	108-940	Cylinder, Pump	1
12	106-014	O-Ring	1
13	106-012	Ball Cage, SS	1
14	138-340	Ball, SS	1
15	107-013	Foot Valve Assembly	1

NOTE: It is not necessary to overtighten foot valve and cylinder into pump block. O-Ring seals perform sealing function without excessive tightening. **Full thread engagement** is sufficient. The Foot Valve may be rotated back up to 1/2 turn from full engagement for convenient hose position.

For syphon hose attachment, it is **critically important** that the threads of the syphon hose fit snugly into the foot valve with the hose assembly couplings PTFE taped and sealed to prevent air leakage.

107-051 SERVICE KIT, MAJOR, PUMP

ITEM NO.	PART NO.	DESCRIPTION	QUANTITY
	107-051	Service Kit, Pump	1
6	107-029	Displacement Rod	1
11	107-936	Pump Cylinder	1

107-051 SERVICE KIT, MINOR, PUMP

ITEM NO.	PART NO.	DESCRIPTION	QUANTITY
1	143-019	Retainer Ring	1
3	106-015	O-Ring, PTFE	2
4	106-002	Packing Set, Leather/UHMWPE	2
7	106-116	Sleeve	1
8A	106-002	Packing Set, Leather/UHMWPE	1
9	569-021	Ball, SS	1
12	106-014	O-Ring	1
14	138-340	Ball, SS	1
	426-051	Sealant, Loctite	1
	753-024	Sealant, Tape, PTFE	1

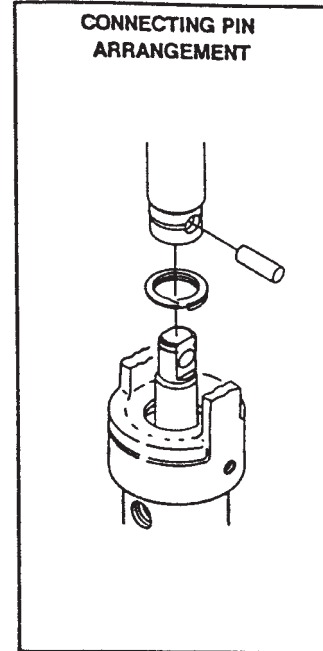

Inlet Accessories Hoses and Valves

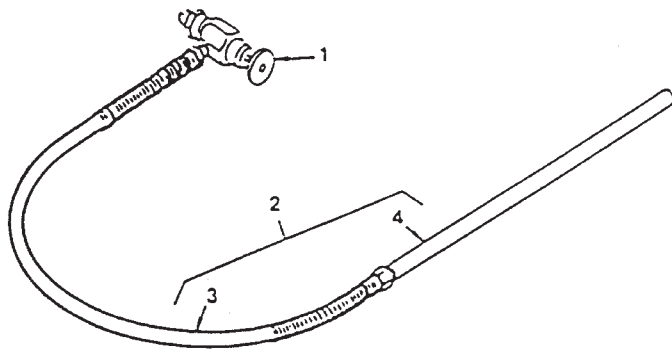

840-211 BLEED LINE ASSEMBLY WITH VALVE

ITEM NO.	PART NO.	DESCRIPTION	QUANTITY
1	944-620	Bleed Valve	1
2	103-111	Bleed Line Assembly	1
3	539-078	Hose Assembly	1
4	103-117	Tube	1

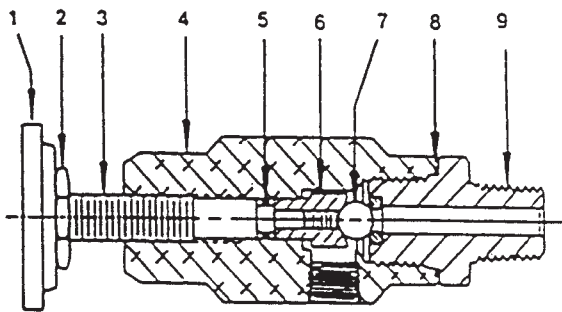

944-620 BLEED VALVE ASSEMBLY

ITEM NO.	PART NO.	DESCRIPTION	QUANTITY
1	944-005	Knob	1
2	860-721	Nut, Lock	1
3	944-023	Valve Stem	1
5	944-004	O-Ring	1
6	944-026	Valve Stem Stop	1
7	569-170	Ball, T.C.	1
8	945-003	Gasket, Copper	1
9	944-904	Valve Seat	1

SERVICE INSTRUCTIONS

The 944-620 Series Bleed Valve has a Tungsten Carbide Seat (9) and should not require frequent replacement. The Tungsten Carbide Ball (7), in normal service, will last a long time because it rotates and wears evenly. If there is leakage, replace the ball. **CAUTION:** Open the Adjustment Knob (1), to full counterclockwise position before unthreading Valve Seat (9), from Valve Body (4). If the Valve Stem (3) is rotated inwardly with the ball removed, the PTFE O-Ring (5), may require replacement. If there has been leakage from the valve stem, the PTFE O-Ring should be replaced. **IMPORTANT:** The Valve Stem Stop (6), must be unthreaded from the Valve Stem (3), with a socket screwdriver, then the valve stem can be threaded out of the Valve Body. **CAUTION:** All non-moving threads must be assembled with Loctite Sealant, Speeflo Part # 426-051.

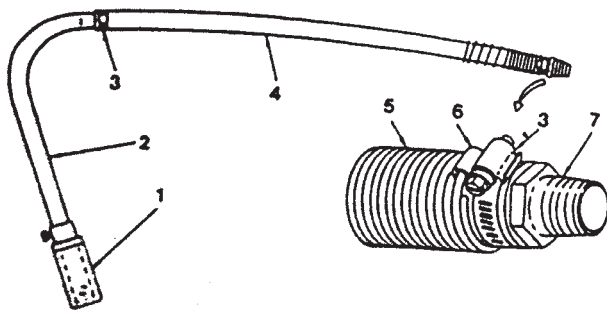

SYPHON HOSE ASSEMBLY

ITEM NO.	PART NO.	DESCRIPTION	103-826 QTY	103-827 QTY
1	103-627	Rock Catcher	1	1
2	103-575	Tube	1	
2a	103-585	Tube		1
3	103-679	Hose Clamp	2	2
4	420-700	Hose	4.5'	6.5'
5	103-125	Spring	1	1
6	103-119	Clip	1	1
7	194-761	Adapter	1	1

Outlet Accessories

920 Outlet Manifold Filter Assembly

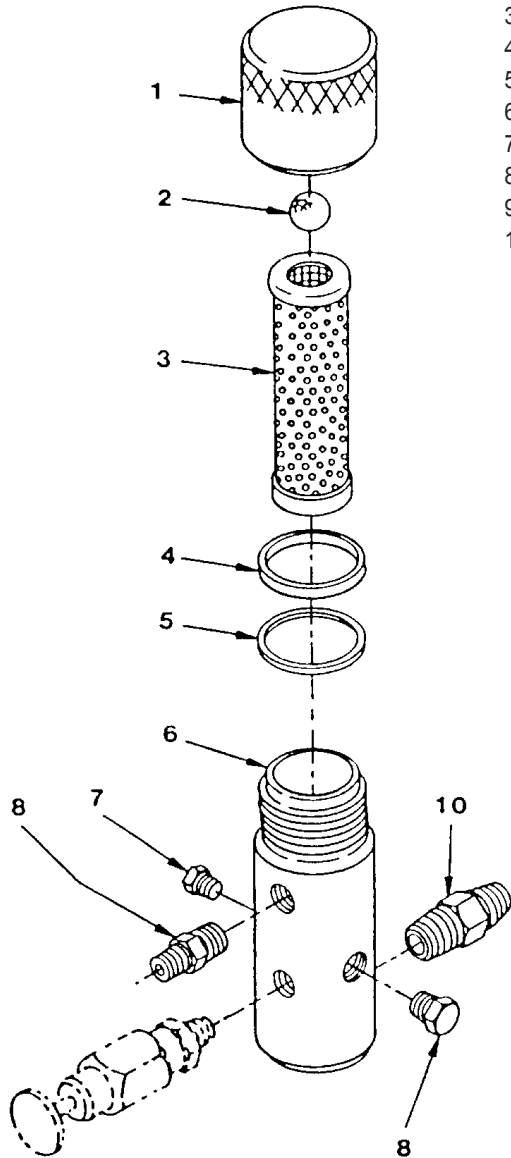

OUTLET MANIFOLD FILTER ASSEMBLY			
ITEM NO.	PART NO.	DESCRIPTION	QTY
1	920-917	Filter Cap Assembly	1
2	920-103	Ball	1
3	920-004	Filter Element, 50 M	1
4	920-006	Gasket, PTFE (Thick)	1
5	920-070	Gasket, PTFE (Thin)	1
6	920-927	Filter Body	1
7	227-027	Plug, Pipe	1
8	812-003	Nipple, Hex	1
9	227-033	Plug, Pipe	1
10	191-449	Nipple	1

PART NO. 920-050 FILTER SERVICE KIT			
ITEM NO.	PART NO.	DESCRIPTION	QUANTITY
2	920-103	Ball	1
4	920-006	Gasket, PTFE	1
5	920-070	Gasket, PTFE	1

SPECIFICATIONS	
Maximum Working Pressure	5000 psi (345 bar)
Filter Area	18 In ² (116 cm ²)
Outlet Ports	(1) 1/4" NPT(F) for bleed valve (1) 3/8" NPT(F) with 1/4 NPSM(M) hose connection (1) 3/8" NPT(F) plugged for additional gun hookup.
Wetted Parts	Carbon steel with electroless nickel and cadmium plating, stainless steel, tungsten carbide, PTFE

Outlet Accessories

930 Outlet Manifold Filter Assembly with Check Valve

OPERATION

The 930 Series Outlet Manifold Filter has a built in spring actuated check valve. It uses a replaceable filter element with a stainless steel check ball permanently trapped inside the element. The element is available in the following screen sizes:

PART NO.	MESH	TYPICAL APPLICATIONS
930-005	5	Heavy materials, high builds, block filters, elastomerics, multicolors, etc.
930-006	50*	Conventional architectural and protective coatings
930-007	100	Lacquers, stains, fine finishes

The filter cap has a long stem which acts as a spring guide and controls ball travel within the filter element. The filter body has a replaceable tungsten carbide seat which is secured by a PTFE O-Ring.

The incorporation of this spring loaded check valve into the filter manifold greatly reduces hydraulic shock at stroke changeover and reduces opportunity for hydraulic stalls. Always use the 930 Series Filter Element / Check Ball in the PowrTwin 4500™ System. Do not use 920 Series filter elements. Do not run the PowrTwin 4500™ system without a 930 Series filter element/check ball. When using heavy high viscosity materials, use the 5-mesh filter element/check ball.

CLEANING

Clean filter regularly. Dirty or clogged filters can greatly reduce filtering ability and cause a number of system problems including poor spray patterns, clogged spray tips, etc.

To clean the filter, shutoff system and relieve all system pressure. See the Pressure Relief Procedure on Page 12.

Remove filter cap with spring guide (1) and spring (2). Pull filter element with check ball (3) straight out of filter body (10). Thoroughly clean inside filter body (10) filter element with check ball (3) and filter cap with spring guide (1) with appropriate solvent. Use care in handling parts as dirt, debris, scratches or nicks may prevent O-Rings or gaskets from sealing.

The 930 Series Filter Elements filter from the inside out. Be certain to clean the screen element thoroughly on the inside. Soak in solvent to loosen hardened paint. etc. or replace.

SERVICE

NOTE: Inspect all parts thoroughly.

1. Inspect ball trapped inside filter element (3). If ball has pressure cuts or scratches, replace filter element.
2. If ball is cut, remove PTFE O-Ring (6) with an O-Ring pick and remove Tungsten Carbide Seat (7). Check carbide seat for nicks or grooves. If seat is nicked or grooved replace.
3. Removal of the PTFE O-Ring (6) for Seat (7) inspection will damage the O-Ring and require replacement.
4. Remove the Spring (2) from the Filter Cap (1). Measure the length of the spring, uncompressed. If it measures less than 3/4" from end to end, replace. Push spring back onto spring guide until it "snaps" in place.
5. Inspect the PTFE Gaskets (4, 5) and O-Ring for deformity, nicks,

cuts, etc. Replace as required.

REASSEMBLY

NOTE: The PTFE O-Ring (6) and PTFE Gaskets (4, 5) are conveniently packaged in Service Kit, Part No. 930-050.

After inspecting and cleaning all parts, reassemble.

1. Place Tungsten Carbide Seat (7) in filter body, using care to place "beveled side" up.
2. Place PTFE O-Ring (6) in groove on the O.D. of the Tungsten Carbide Seat (7).
3. Place Filter element/check Ball (3) back in Filter Body (10). Note: Top and bottom are identical.
4. Place Spring (2) back onto spring guide in Filter Cap (1). Push spring onto guide rod until it "snaps" in place.
5. Place thin PTFE Gasket (5) onto step at top of the Filter Body (10).
6. Place thick PTFE Gasket (4) onto top of the Gasket (15).
7. Tighten Filter Cap (1) onto Filter Body (10). This will engage O-Ring (6) against Tungsten Carbide Seat (7).

PowrTwin 4500™ Outlet Accessories (Optional) Gun Manifold Assemblies

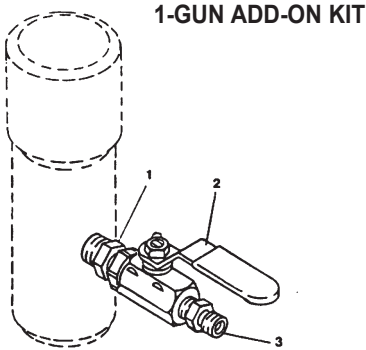

ITEM NO.	PART NO.	DESCRIPTION	GUN MANIFOLD ASSEMBLIES			
			975-111 1-GUN ADD-ON 1/4"	975-311 1-GUN ADD-ON 3/8"	975-200 ADD-A-GUN KIT 1/4"	975-300 ADD-A-GUN KIT 3/8"
1	814-002	Nipple, Hex	1		1	
1a	814-004	Nipple, Hex		1		1
2	940-553	Valve, Ball	1		1	
2a	941-555	Valve, Ball		1		1
3	227-006	Nipple, Hex	1		1	
3a	808-555	Nipple, Hex		1		1
4	227-033	Plug, Pipe			1	1
5	970-100	Block, Manifold			1	1
6	814-004	Nipple, Hex			1	1

ADD-A-GUN KIT

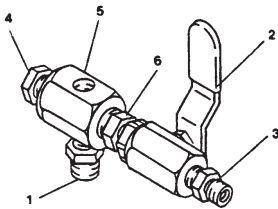

3-GUN MANIFOLD ASSEMBLY

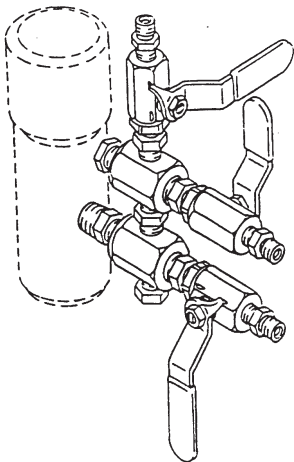

PART NO.	DESCRIPTION	MULTIPLE GUN MANIFOLD ASSEMBLIES			
		975-212 2-GUN 1/4"	975-213 3-GUN 1/4"	975-312 2-GUN 3/8"	975-313 3-GUN 3/8"
975-111	1-GUN ADD-ON, 1/4"	1	1	1	
975-311	1-GUN ADD-ON, 3/8"			1	1
975-200	ADD-A-GUN Kit, 1/4"	1	2	3	
975-300	ADD-A-GUN Kit, 3/8"			1	2

Key Accessories and Service Kits

SAE O-RING FITTING INSTALLATION

These items may be purchased separately from your local TITAN/SPEEFLO distributor.

PART NO.	DESCRIPTION
103-826	Syphon Hose Assembly with Rock Catcher 1" x 4-1/2"
103-827	Syphon Hose Assembly with Rock Catcher 1" x 6-1/2'
103-627	Rock Catcher
930-005	Paint Filter Element, 5 Mesh (for multicolors and heavy materials)
930-006	Paint Filter Element, 50 Mesh (for latex and normal architectural materials)
930-007	Paint Filter Elements, 100 Mesh (for stains, lacquers and fine materials)
711-001	Gun and Hose Kit - For Architectural Coatings - (includes 520-100 Gun with 641-517 SC-5 Reversible Tip and 250-514 1/4" x 50' 3000 psi Airless Hose Assembly)
711-003	Gun and Hose Kit - For Heavy Materials - (includes 801-309 Heavy Material H-Gun w/Swivel, 250-138 3/8" x 50' 3500 psi Airless Hose Assembly, 641-300 SC-5 Safety Guard and 641-621 SC-5 Reversible Tip, .021 x 60°)
160-124	Nylon Paint Strainer - 1 Gallon (Pack of 24)
160-524	Nylon Paint Strainer - 5 Gallon (Pack of 24)
101-208	Grounding Clamp
101-212	Grounding Wire, 12 Gauge x 25'
700-925	Piston Lube
430-362	Coolflo™ Hydraulic Fluid, 1 Quart
430-361	Coolflo™ Hydraulic Fluid, 1 Gallon
143-050	Service Kit for PowrTwin 4500™ Fluid Pump
930-050	Service Kit for Paint Filter
944-050	Service Kit for Bleed Valve
975-212	2-Gun Manifold with Ball Valves, 1/4"
975-213	3-Gun Manifold with Ball Valves, 1/4"
975-312	2-Gun Manifold with Ball Valves, 3/8"
975-313	3-Gun Manifold with Ball Valves, 3/8"

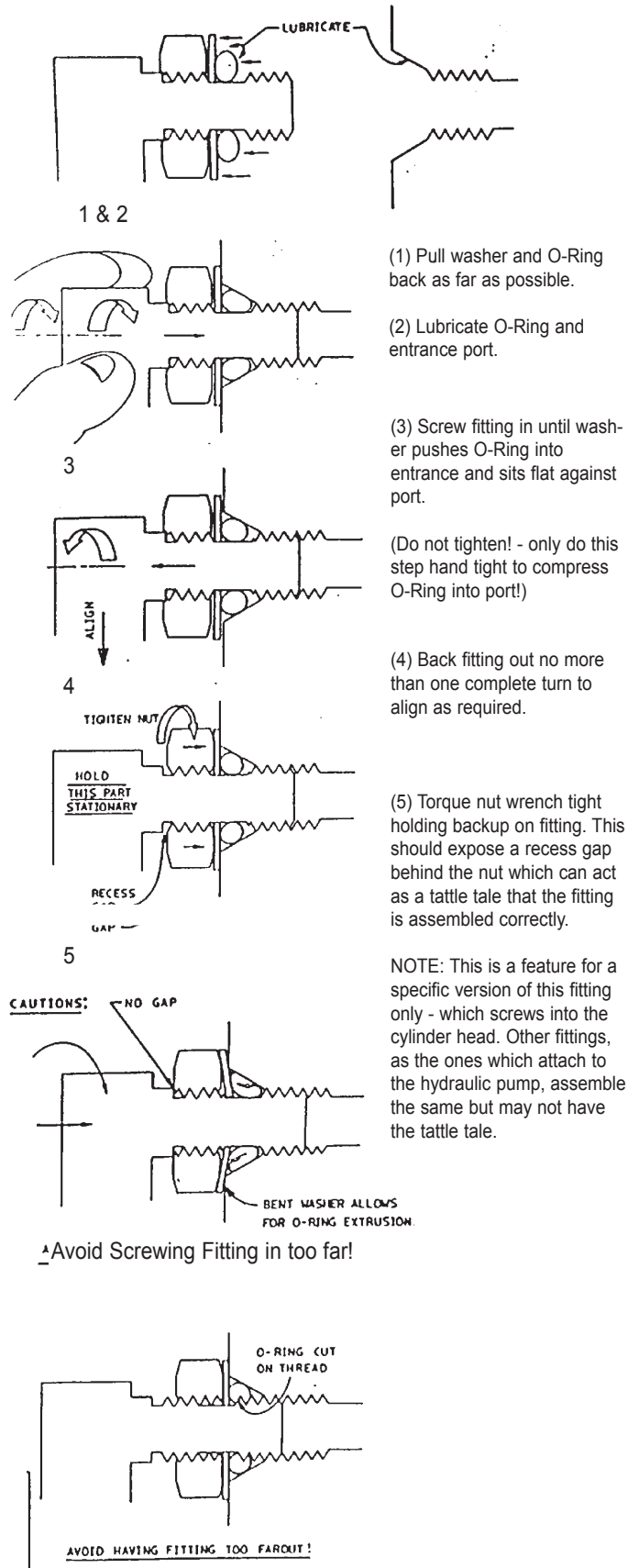

(1) Pull washer and O-Ring back as far as possible.

(2) Lubricate O-Ring and entrance port.

(3) Screw fitting in until washer pushes O-Ring into entrance and sits flat against port.

(Do not tighten! - only do this step hand tight to compress O-Ring into port!)

(4) Back fitting out no more than one complete turn to align as required.

(5) Torque nut wrench tight holding backup on fitting. This should expose a recess gap behind the nut which can act as a tattle tale that the fitting is assembled correctly.

NOTE: This is a feature for a specific version of this fitting only - which screws into the cylinder head. Other fittings, as the ones which attach to the hydraulic pump, assemble the same but may not have the tattle tale.

TITAN LIMITED WARRANTY

Titan Tool Inc. warrants all equipment manufactured by it and bearing its brand names to be free from defects in material and workmanship at the time of sale by an authorized Titan/Speeeflo distributor. Titan Tool Inc. will for a period of twelve months (twenty-four months on selected air powered models) from the date of sale, repair or replace any part of the equipment proven defective. Repair or replacement under this warranty shall be purchaser's sole remedy for breach of this warranty. Products furnished by but not manufactured by Titan Tool Inc. (such as hose, motors, engines, hydraulic pumps, etc.) will carry only the warranty of the manufacturer, if any. (TITAN TOOL INC. DOES NOT WARRANT AND DISCLAIMS ALL IMPLIED WARRANTIES OF MERCHANTABILITY AND FITNESS FOR A PARTICULAR PURPOSE FOR ACCESSORIES, MATERIALS, EQUIPMENT, COMPONENTS AND PRODUCTS NOT MADE BY TITAN TOOL INC.)

This warranty shall not apply if the product has been subject to misuse, negligence, accident or tampering or has not been operated or installed in accordance with Titan Tool Inc.'s recommendations. This warranty does not cover and Titan Tool Inc. shall not be liable for any damage, wear or malfunction caused by improper or inadequate maintenance, abrasion, corrosion or substitution of components, parts or hydraulic fluid not supplied by Titan Tool Inc. Titan Tool Inc. shall not be liable for the improper design, manufacture, installation, operation or maintenance of accessories, components or materials not supplied by Titan Tool Inc. Titan Tool Inc. shall not be liable for damage or wear caused by incompatibility with Titan Tool Inc. equipment of materials, equipment or accessories not supplied by Titan Tool Inc.

This warranty applies only to the original purchaser and only when the equipment is installed, operated and maintained in accordance with Titan Tool Inc.'s written recommendations or instructions. Purchaser must, with transportation prepaid, return the equipment claimed to be defective to Titan Tool Inc. or to an authorized Warranty Service Center for verification of the claimed defect. If the alleged defect is verified,

Titan Tool Inc. will, at Titan Tool Inc.'s option, repair or replace any defective parts. The equipment will be returned including prepayment of transportation charges to the original purchaser. If no defects in material and workmanship are found, repairs will be made by Titan Tool Inc. at a reasonable charge. Charges may include the cost of parts, labor and freight.

No statement or recommendation made or assistance given by Titan Tool Inc. or its representatives to purchaser, lessee or user or its representatives shall constitute a warranty by Titan Tool Inc. or a waiver or modification of any of the provisions hereof to create any liability for Titan Tool Inc. No sample or model shall create an express warranty that the products shall conform to any sample or model exhibited by Titan Tool Inc.

TITAN TOOL INC. DISCLAIMS TO THE FULL EXTENT PERMITTED BY LAW ALL WARRANTIES, EXPRESSED OR IMPLIED, INCLUDING ANY WARRANTY OF MERCHANTABILITY OR WARRANTY OF FITNESS FOR A PARTICULAR PURPOSE AND ANY NON CONTRACTUAL LIABILITIES INCLUDING PRODUCT LIABILITY BASED ON NEGLIGENCE OR STRICT LIABILITIES. Every form of liability is expressly excluded and denied for direct, indirect, special or consequential damages or loss. This warranty shall be in lieu of any other warranty expressed or implied. The terms of this warranty constitute purchaser's sole and exclusive remedy. In no case shall Titan Tool Inc.'s liability exceed the amount of the purchase price. Any action for breach of warranty must be brought within two (2) years of the date of sale.

TITAN
TOOL INC.



© 1999 Titan Tool Inc.
313-1015 Printed in the U.S.A.
0699, REV B

National Sales & Service
1-800-526-5362
Fax 1-800-528-4826

556 Commerce Street
Franklin Lakes, NJ 07417

Canadian Branch
1-800-565-8665
Fax 1-905-856-8496

200 Trowers Road, Unit 7B
Woodbridge, L4L 5Z8

International
1-201-405-7520
Fax 1-201-405-7449

556 Commerce Street
Franklin Lakes, NJ 07417 USA

TITAN and Speeeflo are registered trademarks of Titan Tool Inc.